

REVISONS		DATE	DWN	APVD
P	LTR			
B	REV PER ECO 08-009474	7/22/2008	DW	JL

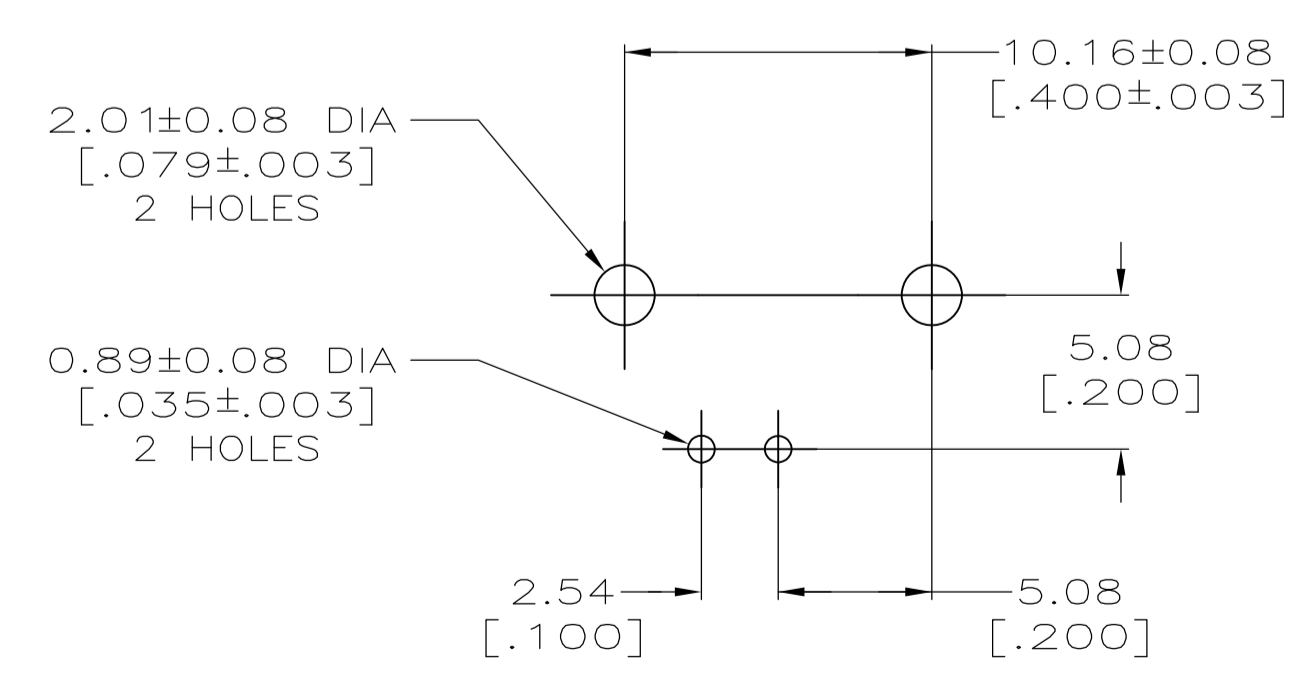
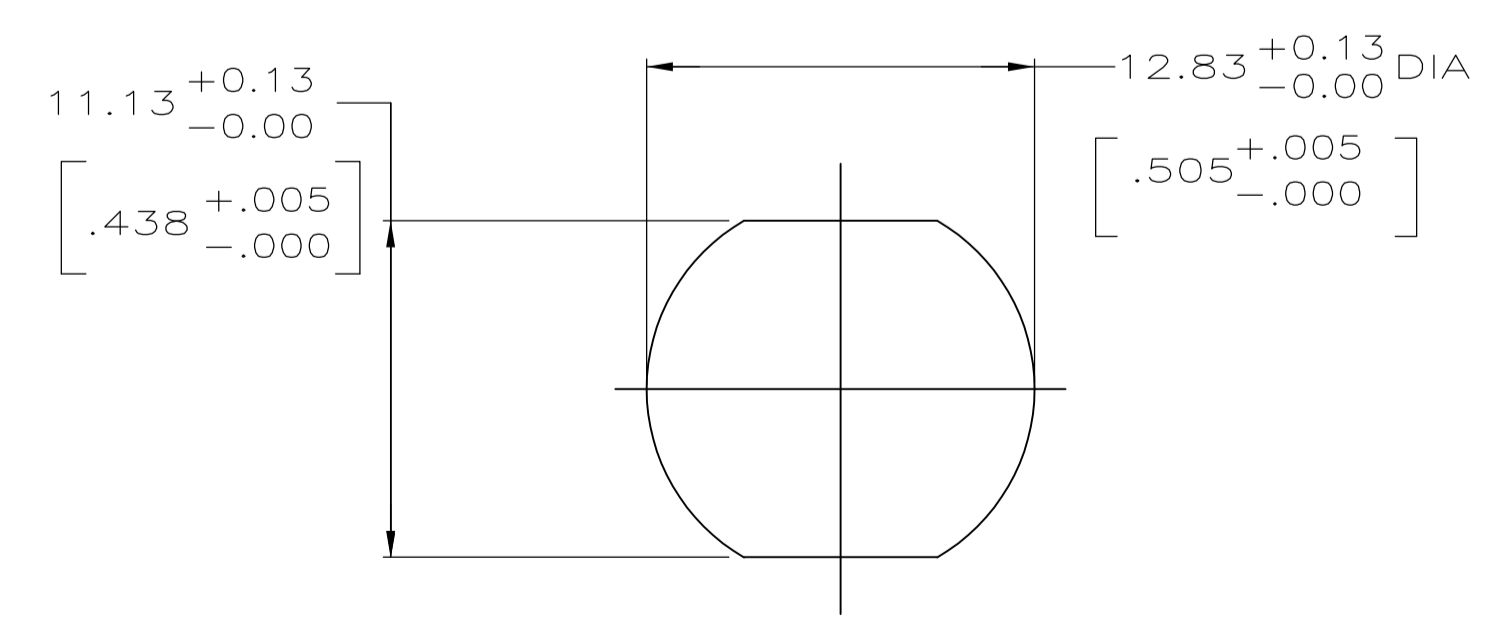
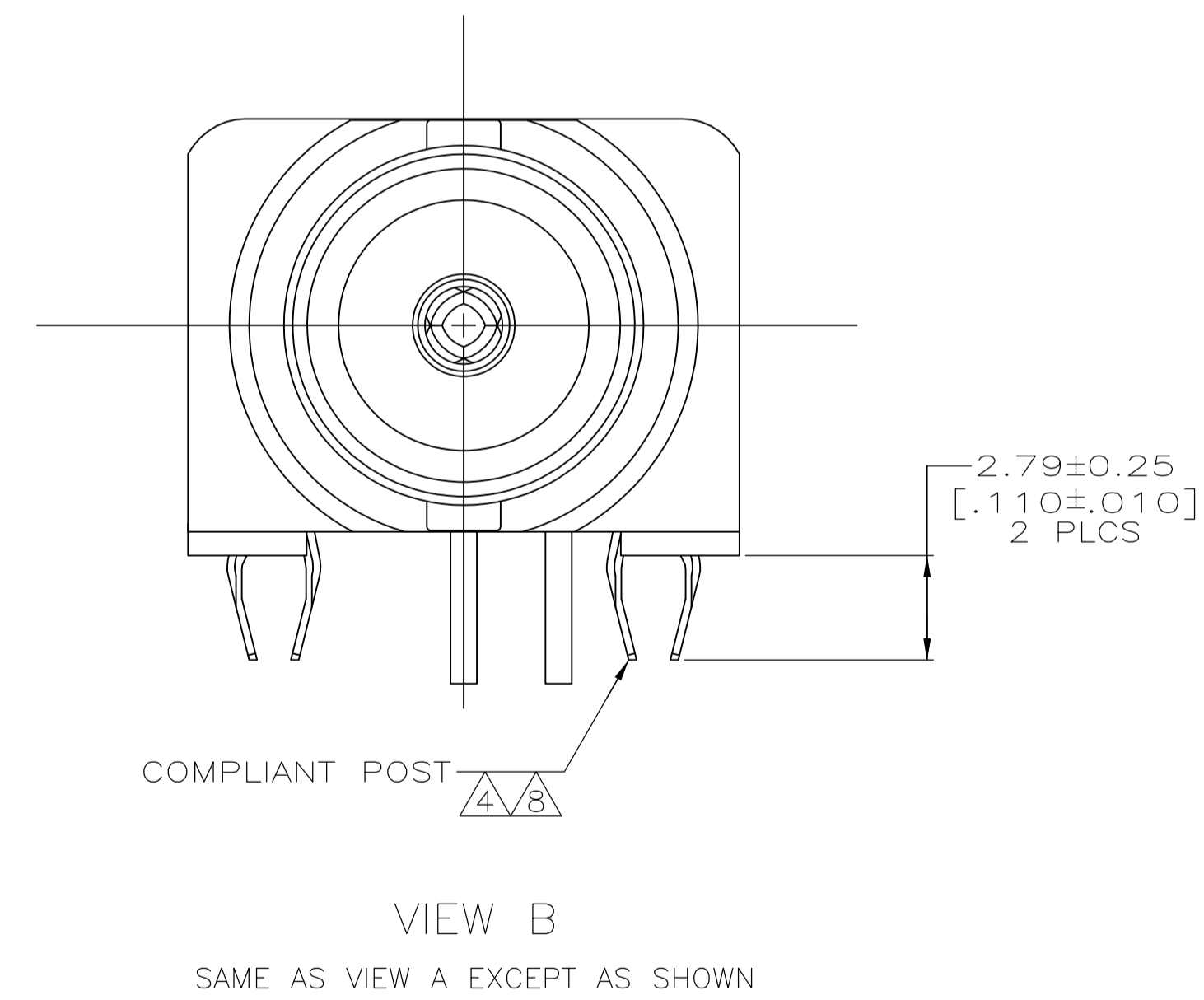
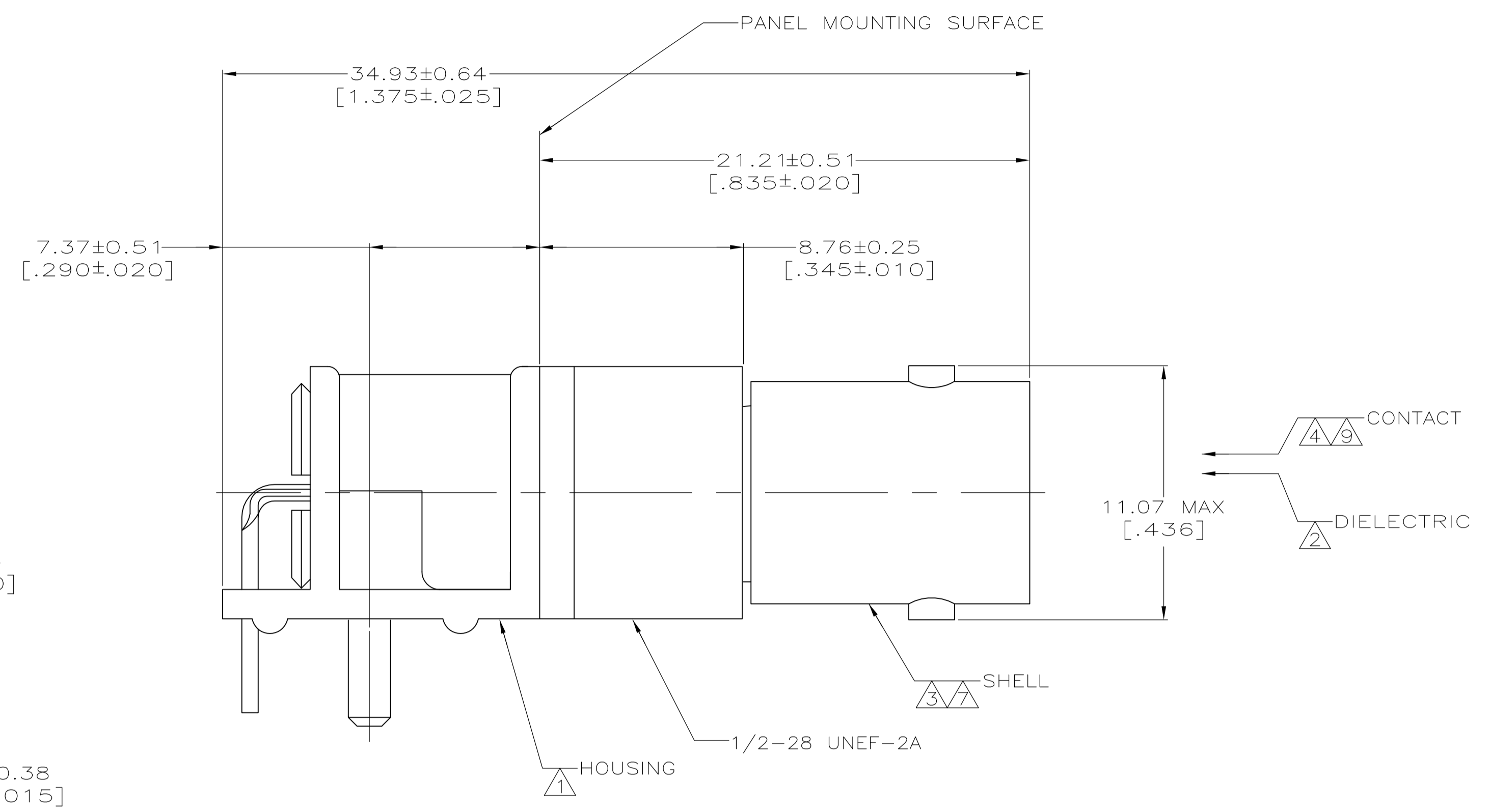
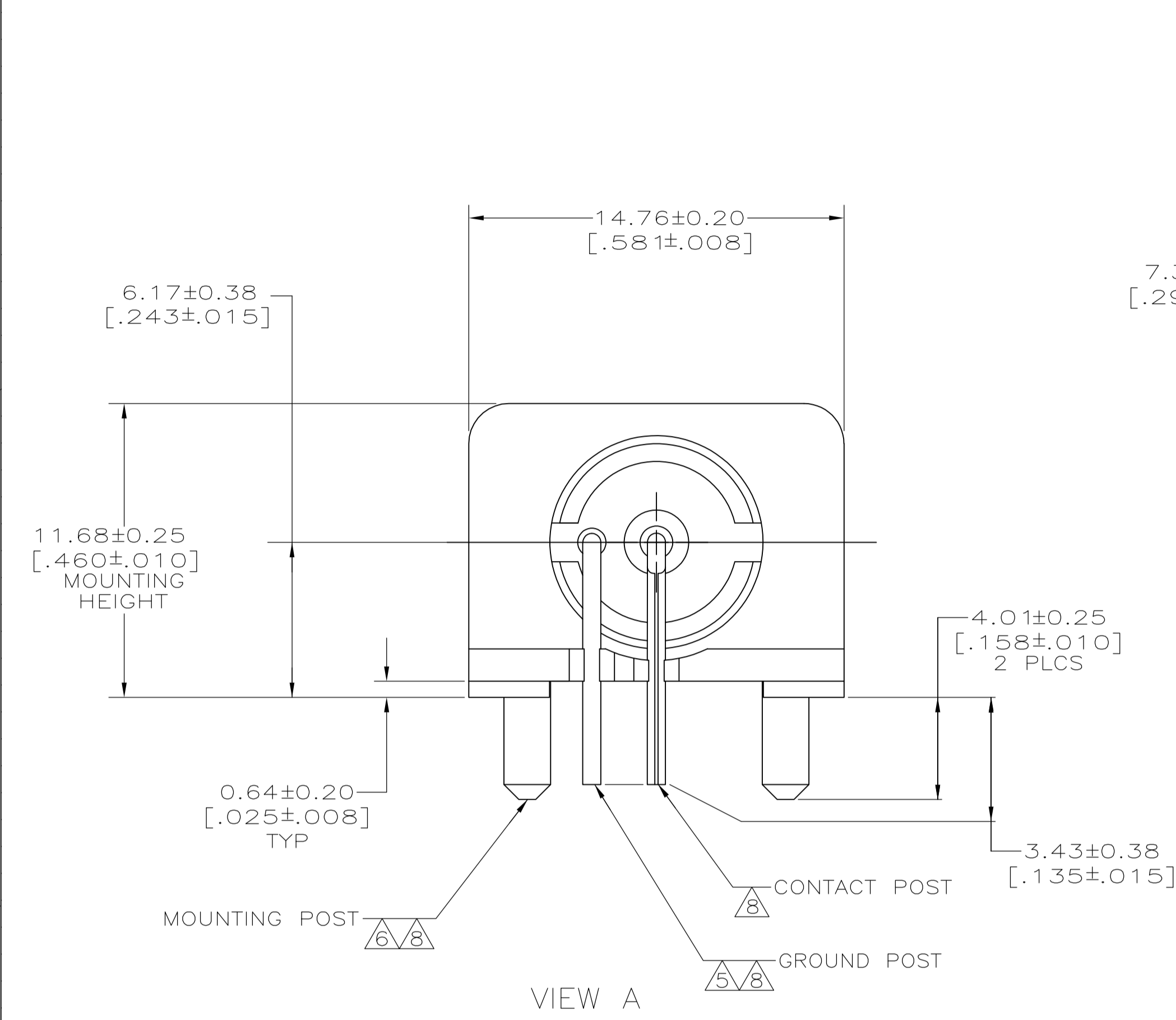

- 1 POLYESTER PBT PER MIL-M-24519, TYPE GPT-15F, UL94V-0 RATED, COLOR:BLACK
- 2 POLYMETHYLPENTENE, GENERAL PURPOSE.
- 3 ZINC PER QQ-Z-363.
- 4 PHOSPHOR BRONZE PER QQ-B-750.
- 5 BRASS PER ASTM-B-453.
- 6 BRASS PER ASTM-B-16.
- 7 NICKEL PLATE PER QQ-N-290, 3.81 μm [.000150] MINIMUM THICK.
- 8 TIN PLATE PER ASTM-B-545, 3.81 μm [.000150] MINIMUM THICK.
- 9 GOLD PLATE PER ASTM-B-488, 0.08 μm [.000003] MINIMUM THICK.
10. SEE INSTRUCTION SHEET 408-2769.

VIEW	PART NUMBER
B	5415105-2
A	5415105-1

THIS DRAWING IS A CONTROLLED DOCUMENT.		DIMENSIONS: mm [INCHES] TOLERANCES UNLESS OTHERWISE SPECIFIED: 0 PLC ± - 1 PLC ± - 2 PLC ± 0.05 [.002] 3 PLC ± - 4 PLC ± - ANGLES ± -		MATERIAL: SEE NOTES 1 THRU 6 FINISH: SEE NOTES 7 THRU 10	
BIN: J. ALCORTA - DOCK 5 CIK: J. HAVENER APVD: J. LIPPERT PRODUCT SPEC: - APPLICATION SPEC: - WEIGHT: -		Tyco Electronics Corporation Harrisburg, PA 17105-3608 NAME: JACK, RIGHT ANGLE, 75 OHM, PCB, BNC SIZE: A1 CAGE CODE: 00779 DRAWING NO: 5415105 RESTRICTED TO: -		CUSTOMER DRAWING SCALE: 6:1 SHEET: 1 OF 1 REV: B	