

## 150mA, 75V Surface Mount Switching Diode

### FEATURES

- Low power loss, high efficiency
- High surge current capability
- Hermetically sealed glass
- RoHS Compliant

### APPLICATIONS

- Switching mode power supply (SMPS)
- Adapters
- Lighting application
- On-board DC/DC converter

### MECHANICAL DATA

- Case: MMELF
- Terminal: Matte tin plated leads, solderable per J-STD-002
- Polarity: Indicated by cathode band
- Weight: 30.60mg (approximately)

KEY PARAMETERS		
PARAMETER	VALUE	UNIT
$I_F$	150	mA
$V_{RRM}$	75	V
$I_{FSM}$	4	A
$V_F$ at $I_F = 100\text{mA}$	1	V
$T_{J\text{MAX}}$	175	°C
Package	MMELF	
Configuration	Single die	

**MMELF**

ABSOLUTE MAXIMUM RATINGS ( $T_A = 25^\circ\text{C}$ unless otherwise noted)			
PARAMETER	SYMBOL	VALUE	UNIT
Power dissipation	$P_D$	500	mW
Repetitive peak reverse voltage	$V_{RRM}$	75	V
Forward current	$I_F$	150	mA
Non-repetitive peak forward surge current	$I_{FSM}$	$t = 1\text{s}$	0.5
		$t = 1\text{ms}$	1.0
		$t = 1\mu\text{s}$	4.0
Repetitive peak forward current	$I_{FRM}$	450	mA
Junction temperature range	$T_J$	-65 to +175	°C
Storage temperature range	$T_{STG}$	-65 to +175	°C

THERMAL PERFORMANCE			
PARAMETER	SYMBOL	LIMIT	UNIT
Junction-to-ambient thermal resistance	$R_{\theta JA}$	300	°C/W

<b>ELECTRICAL SPECIFICATIONS</b> ( $T_A = 25^\circ\text{C}$ unless otherwise noted)						
<b>PARAMETER</b>	<b>CONDITIONS</b>		<b>SYMBOL</b>	<b>MIN</b>	<b>MAX</b>	<b>UNIT</b>
Reverse Breakdown Voltage	$I_R = 100\mu\text{A}$		$V_{BR}$	100	-	V
	$I_R = 5\mu\text{A}$			75	-	V
Forward voltage <sup>(1)</sup>	LL4448 LL914B	$I_F = 5\text{mA}, T_J = 25^\circ\text{C}$	$V_F$	0.62	0.72	V
	LL4148	$I_F = 50\text{mA}, T_J = 25^\circ\text{C}$		-	1	V
	LL4448 LL914B	$I_F = 100\text{mA}, T_J = 25^\circ\text{C}$		-	1	V
Reverse current @ rated $V_R$ <sup>(2)</sup>	$V_R = 20\text{V}, T_J = 25^\circ\text{C}$		$I_R$	-	25	nA
	$V_R = 75\text{V}, T_J = 25^\circ\text{C}$			-	5	$\mu\text{A}$
Junction capacitance	1 MHz, $V_R=0\text{V}$		$C_J$	-	4	pF
Reverse Recovery Time	$I_F = I_R = 10\text{mA},$ $R_L = 100\Omega, I_{RR} = 1\text{mA}$		$t_{rr}$	-	4	ns

**Notes:**

1. Pulse test with  $PW = 0.3\text{ms}$
2. Pulse test with  $PW = 30\text{ms}$

<b>ORDERING INFORMATION</b>		
<b>ORDERING CODE<sup>(1)</sup></b>	<b>PACKAGE</b>	<b>PACKING</b>
LL4148 L0	MMELF	10,000 / 13" Tape & Reel
LL4448 L0	MMELF	10,000 / 13" Tape & Reel
LL914B L0	MMELF	10,000 / 13" Tape & Reel
LL4148 LOG	MMELF	10,000 / 13" Tape & Reel
LL4448 LOG	MMELF	10,000 / 13" Tape & Reel
LL914B LOG	MMELF	10,000 / 13" Tape & Reel

**Notes:**

1. Above ordering codes L0/LOG refer to physically identical parts without any differences

**CHARACTERISTICS CURVES**

( $T_A = 25^\circ\text{C}$  unless otherwise noted)

**Fig.1 Typical Forward Characteristics**

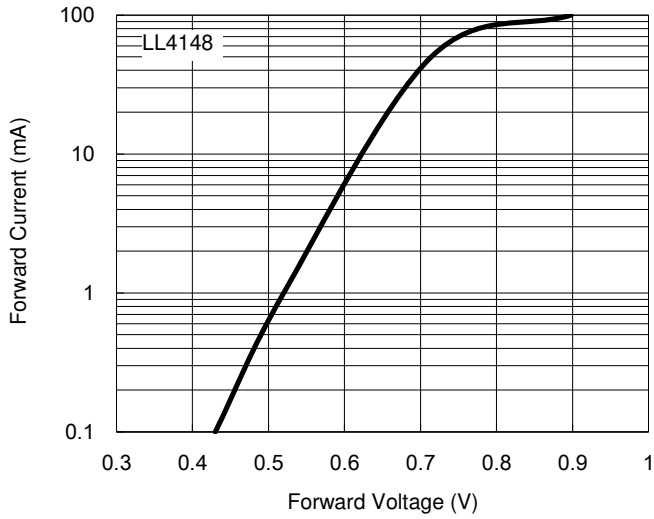

**Fig.2 Reverse Current VS. Reverse Voltage**

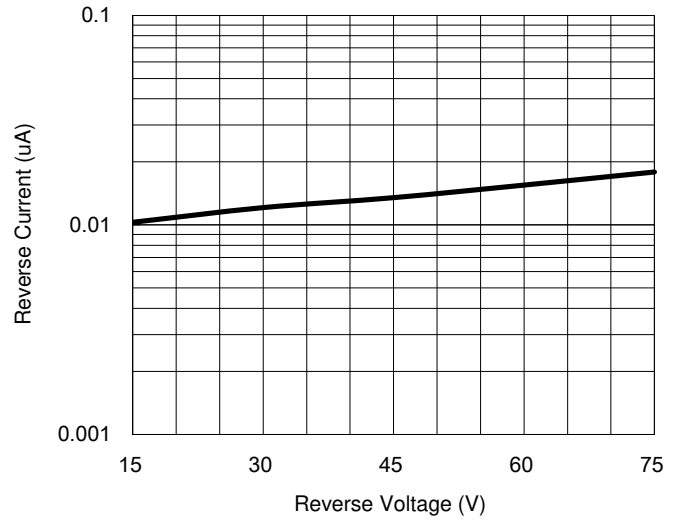

**Fig.3 Admissible Power Dissipation Curve**

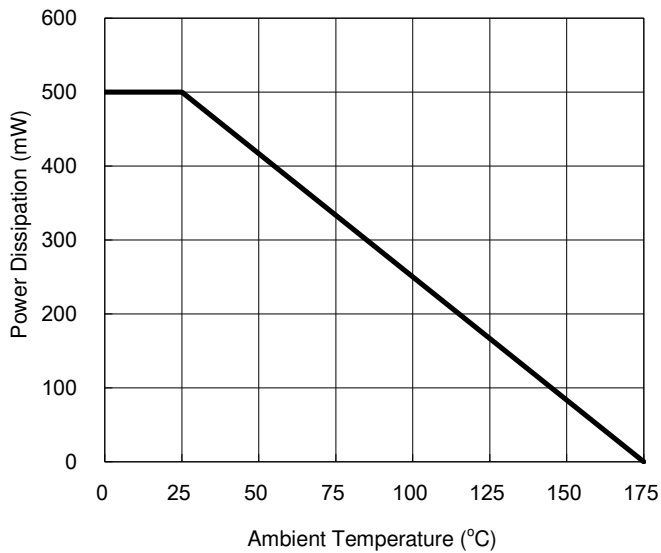

**Fig.4 Typical Junction Capacitance**

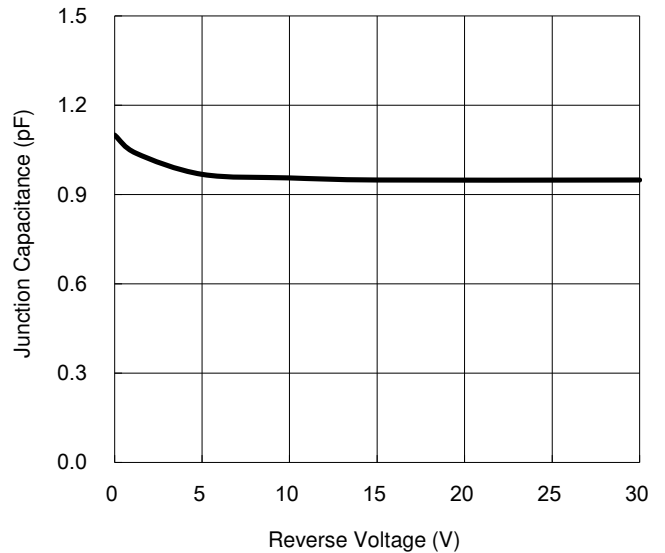

**CHARACTERISTICS CURVES**

( $T_A = 25^\circ\text{C}$  unless otherwise noted)

**Fig.5 Forward Resistance VS. Forward Current**

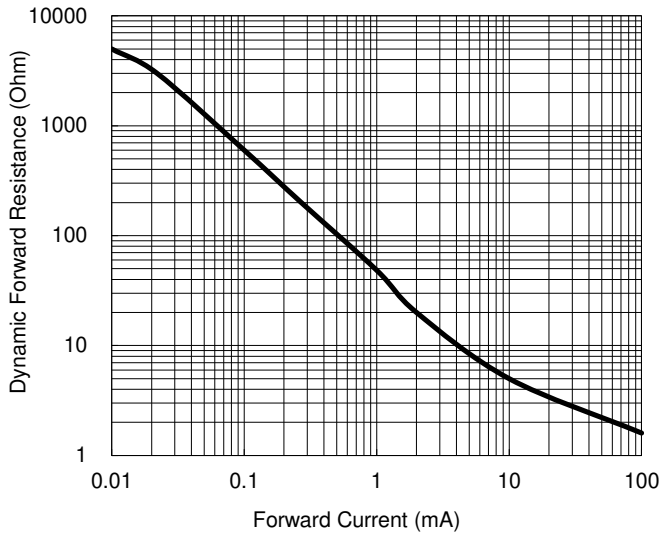

**PACKAGE OUTLINE DIMENSIONS**

**MMELF**

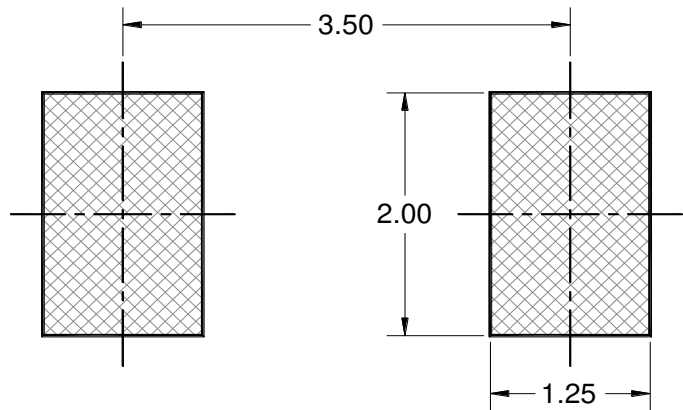
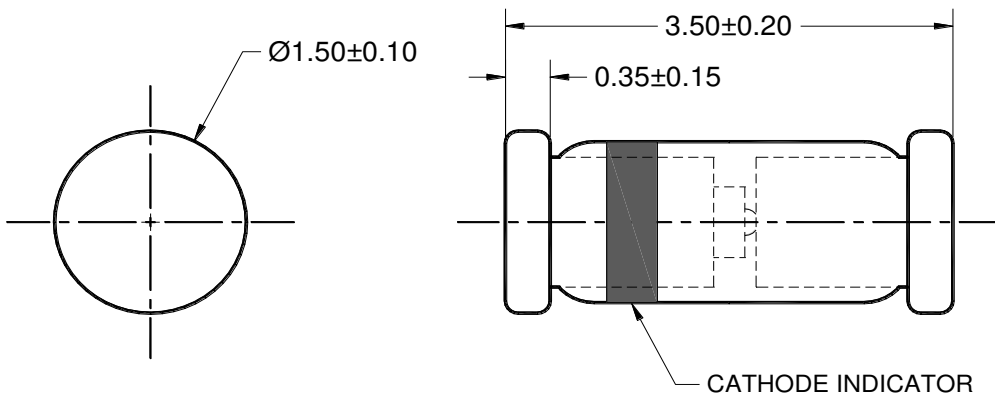

**SUGGESTED PAD LAYOUT**

**NOTES: UNLESS OTHERWISE SPECIFIED**

1. ALL DIMENSIONS ARE IN MILLIMETERS.
2. DIMENSIONING AND TOLERANCING PER ASME Y14.5M-1994.
3. PACKAGE OUTLINE REFERENCE: JEDEC DO-213, VARIATION AA, ISSUE D.
4. DWG NO. REF: HQ2SD07-MMELFG-044 REV A.

## **Notice**

Specifications of the products displayed herein are subject to change without notice. TSC or anyone on its behalf assumes no responsibility or liability for any errors or inaccuracies.

Purchasers are solely responsible for the choice, selection, and use of TSC products and TSC assumes no liability for application assistance or the design of Purchasers' products.

Information contained herein is intended to provide a product description only. No license, express or implied, to any intellectual property rights is granted by this document. Except as provided in TSC's terms and conditions of sale for such products, TSC assumes no liability whatsoever, and disclaims any express or implied warranty, relating to sale and/or use of TSC products including liability or warranties relating to fitness for a particular purpose, merchantability, or infringement of any patent, copyright, or other intellectual property right.

The products shown herein are not designed for use in medical, life-saving, or life-sustaining applications. Customers using or selling these products for use in such applications do so at their own risk and agree to fully indemnify TSC for any damages resulting from such improper use or sale.