

## ZMOD4410

### Evaluation Kit

The [ZMOD4410 Evaluation Kit](#) (EVK) is designed for evaluating Renesas' ZMOD4410 Gas Sensor Module for Indoor Air Quality. The total volatile organic compounds (TVOC) measurement is one of the indicators for indoor air quality (IAQ). In addition, measurement modes are provided to measure the Relative IAQ based on the air quality change, and to discriminate sulfur odors.

*Note:* This document supports the waterproof and non-waterproof ZMOD4410 EVKs.

The *Gas Sensor Evaluation Software* allows Windows®-based operating systems to communicate with the ZMOD4410 EVK via a USB connection on the user's computer, which functions as a master. The software and additional related documentation are available on the [Renesas](#) website.

The EVK's Communication Board (HiCom) handles the interface between the user's computer and the ZMOD4410 module mounted on the ZMOD4410 Sensor Board ("daughter board").

*Note:* Only one Communication Board with one Sensor Board can be connected to the computer at a time.

The ZMOD4410 Evaluation Kit uses an FTDI controller on the Communication Board to handle the USB protocol, translate communications, and synchronize communications with the I<sup>2</sup>C interface. The Sensor Board includes a decoupling capacitor; however, I<sup>2</sup>C pull-up resistors are not assembled and are mounted on the Communication Board.

The Communication Board has devices mounted on both sides. The components on the top side generate a stable supply voltage. A potentiometer can be used to adjust the internal supply voltage in the typical range from 1.8V to 3.6V. Alternatively, the user's external supply voltage can be used. The intensity of the adjacent LED is proportional to the supply voltage.

## Features

- User-friendly EVK expedites configuration and evaluation of the ZMOD4410 Gas Sensor Module
- Water and dustproof version available (IP67 certified)
- Supports different methods of operation, including ultra-low power and AI technology for improved TVOC readings/
- Algorithm output according to different Air Quality Standards, such as UBA and typical Public Building Air Quality (PBAQ) standards
- Operates with Renesas provided software; either with executable ZMOD4410 GUI or alternatively with firmware programming examples
- The modular design of the EVK allows simple connection of Sensor Boards for different gas sensor derivatives and easy integration with other sensor products via the I<sup>2</sup>C interface
- The required Gas Sensor Evaluation Software is available for free download on the Renesas website, which also provides background information on IAQ, TVOC, gas sensing, and how to use the sensor firmware.
- Additional pins to measure power consumption and supply voltage

## ZMOD4410-EVK Contents

- HiCom Communication Board
- Sensor Board with ZMOD4410 Gas Sensor Module
- USB cable (Type-B to Micro-USB)

## ZMOD4410 Evaluation Kit

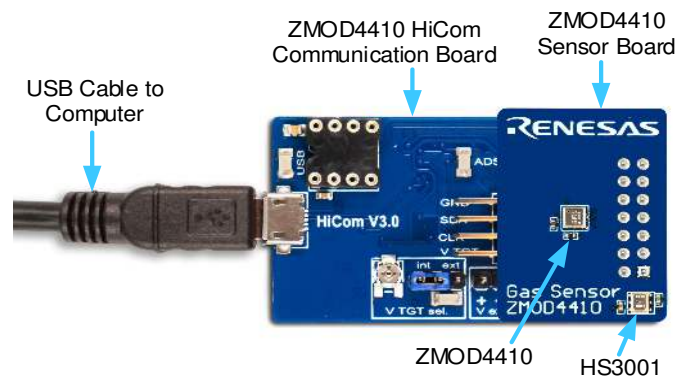



**Important Equipment Warning:** Ensure the correct connection of all cables. Supplying the board using the wrong polarity could result in damage to the board and/or the equipment. Check that all jumpers have been placed as specified in this document.

## Contents

<b>1. Setup</b> .....	<b>4</b>
1.1 Initial Startup.....	4
1.2 Required or Recommended User Equipment .....	4
1.3 User Computer Requirements.....	4
1.3.1. Computer Requirements.....	4
1.4 Software Installation and Setup.....	4
1.5 EVK Hardware Connections and Initial Power-up.....	5
<b>2. Usage Guide</b> .....	<b>7</b>
2.1 Measurement Control Block .....	8
2.2 Signal Analysis Block and Options .....	9
2.3 Plot Visualization Block .....	10
2.4 Error Codes .....	10
<b>3. Schematics</b> .....	<b>12</b>
<b>4. Bill of Materials (BOM)</b> .....	<b>15</b>
<b>5. Board Layout</b> .....	<b>18</b>
<b>6. Ordering Information</b> .....	<b>20</b>
<b>7. Revision History</b> .....	<b>20</b>

## Figures

Figure 1. Initial Display after Starting the Sensor Evaluation Software.....	5
Figure 2. Jumper Settings and Connectors on Top Side of the ZMOD4410 Communication Board.....	6
Figure 3. Jumper Settings, Connections, and Test Points on the Communication Board for the Internal or External Supply Voltage .....	7
Figure 4. Initial Display for the ZMOD4410 Start-Up.....	8
Figure 5. Communication Board Schematic – Page 1 .....	12
Figure 6. Communication Board Schematic – Page 2 .....	13
Figure 7. Sensor Board Schematic.....	14
Figure 8. HiCom Communication Board Layout – Top Layer.....	18
Figure 9. HiCom Communication Board Layout – Bottom Layer .....	18
Figure 10. Sensor Board Layout – Top Layer with PIN Configuration on Connector X1 .....	19
Figure 11. Sensor Board Layout – Bottom Layer .....	19

## Tables

Table 1. Evaluation Kit Connection Descriptions.....	6
Table 2. Analysis Tab User Options .....	9
Table 3. Most Common Error Messages.....	10
Table 4. Communication Board BOM.....	15
Table 5. Sensor Board BOM.....	17
Table 6. PIN Configuration on Connector X1 .....	17

# 1. Setup

## 1.1 Initial Startup

To set up and operate the ZMOD4410 Evaluation Kit (EVK) with the ZMOD4410, refer to the *ZMOD4410 EVK Quick Start Guide* included in the kit.

## 1.2 Required or Recommended User Equipment

By default, the internal supply voltage for powering the Sensor Board is generated from the USB voltage supplied by the user's computer via the USB cable. If there is a need for currents higher than the defined USB Standard (usually 500mA at 5V), an external voltage supply source can be used instead of the internally generated voltage supply provided on the Communication Board.

The external supply powers only the sensor modules, and not the communication board itself. The supply must meet the following requirements:

- Voltage 1.8V to 3.6V
- Current must meet the user's specifications. The minimum is 30mA for electronics with additional need for each gas sensor module of approximately 13mA at 1.8V voltage supply.

## 1.3 User Computer Requirements

### 1.3.1. Computer Requirements

A Windows®-based computer is required for interfacing with the EVK and configuring the ZMOD4410. The user must have administrative rights on the computer to download and install the *Gas Sensor Evaluation Software*.

- The computer must meet the following requirements:
- 1GB RAM
- Hard drive with at least 1GB free space
- 1 USB port
- Windows 7, 8, 10, or 11
- Internet access for initial download of the drivers and software

*Important:* Before installing and activating the software, assemble and connect the hardware for the kit to the user's computer according to steps 1 to 3 in section 1.5.

## 1.4 Software Installation and Setup

Complete the following procedure to download and install the *Gas Evaluation Software* with the kit connected:

1. Download the ZMOD4410 *Gas Sensor Evaluation Software* file from the [ZMOD4410 EVK](#) product page.
2. Double-click on the executable file *GasSensorEvaluation\_Installer* to start and follow the installation steps.
3. During initial installation or repair of *Gas Sensor Evaluation Software*, the USB drivers for the FTDI communication chip may need to be installed. A manual download and installation of the latest FTDI driver is also possible from the [FTDI](#) website. The drivers will not affect the operation of any other USB peripherals.

Figure 1 shows an example of the initial display after execution of the installed *Gas Evaluation Software*. Select a measurement mode to run the sensor. The best sensor module performance can be seen in the "IAQ 2<sup>nd</sup> Gen" operation mode to measure IAQ/TVOC/eCO<sub>2</sub>. To see changes in the air quality, select the "Relative IAQ" option or alternatively choose the "Sulfur Odor Discrimination" to make a differentiation to sulfur based odors. For power critical applications it is recommended to use the Ultra-Low Power (ULP) operation modes, and to meet Public Building Air Quality standards select "PBAQ" in the drop-down menu.

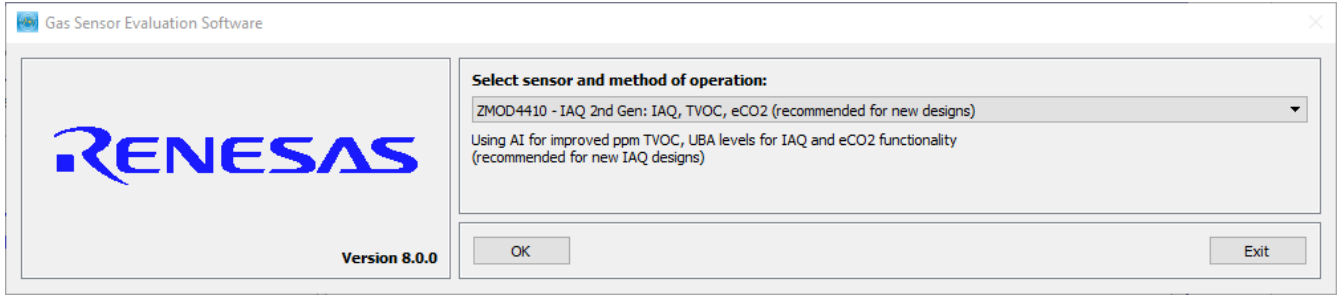

Figure 1. Initial Display after Starting the Sensor Evaluation Software

## 1.5 EVK Hardware Connections and Initial Power-up

To set up the EVK hardware before using the software, complete the following procedure:

1. Refer to Figure 2, Figure 3, and Table 1 to determine the correct jumper settings for the ZMOD4410 Communication Board depending on whether an external supply or the internal voltage supply on the board is used.
  - If the internal voltage supply is used, ensure that the jumper is across the pins labeled “int” on the K2 connector.
  - If using an external supply, ensure that the jumper is across the pins labeled “ext” on the K2 connector. In this case, without connecting the external supply to the Communication Board, verify that the external voltage supply setting does not exceed the voltage supply specifications – a minimum of 1.8V or a maximum of 3.6V – as per the ZMOD4410 Datasheet. With the external supply off, connect the external voltage to the 2-pin “±V ext” header adjacent to the K2 jumper with the orientation indicated in Figure 3.

*Note:* If this option is used, adjustments of the external voltage are not possible on either the Communication Board, or the Sensor Board for adjusting an external voltage supply.

2. Install the ZMOD4410 Sensor Board on the 14-pin connector on the ZMOD4410 Communication Board taking care to ensure the proper orientation of the Sensor Board is as shown on page 1.
3. Insert the micro-USB cable into the X1 connector on the Communication Board and connect it to a free USB port on the user’s computer.

If the external voltage supply has been selected, turn on the external supply and verify that the D3 LED adjacent to the potentiometer is on (see Figure 2). *Note:* The intensity of the green D3 LED is proportional to the supply voltage.

4. Activate the software as described in section 1.4.
5. If the internal voltage is used, the Gas Sensor Evaluation Software activates the internal voltage after the sensor has been started. Use the metal potentiometer to the left of the K2 connector to adjust the VDD supply voltage in the typical range from 1.8V to 3.6V as measured across the V\_TGT and GND pins available on the K3 connector as shown in Figure 3. Its initial adjustment on delivery provides a voltage of  $VDD \approx 2.0V$ . Once a measurement has been started by the software, the green D3 LED adjacent to K2 will light with an intensity proportional to the voltage supply that was set using the potentiometer.
6. Verify that the red D1 LED is on, which indicates that the kit is properly connected and powered (see Figure 2).

The Communication Board provides the additional K1, K3, and Modul1 connectors for the following optional uses as described in Table 1. To make use of any of these options, contact Renesas for further instructions (see contact information on last page).

- Extra measurement options (e.g., current consumption to determine the power requirements of the ZMOD4410)
- Connections for additional sensors via I<sup>2</sup>C interface

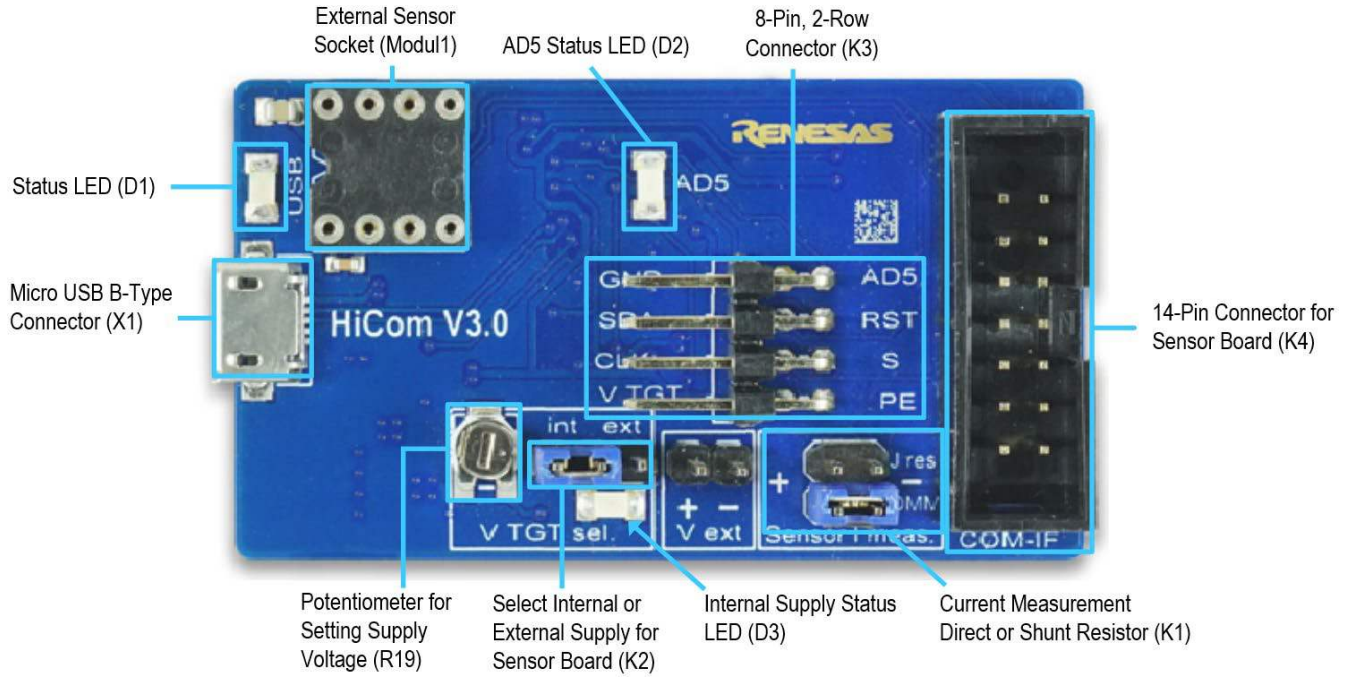

Figure 2. Jumper Settings and Connectors on Top Side of the ZMOD4410 Communication Board

Table 1. Evaluation Kit Connection Descriptions

Connector	Type	Description
K1	4-pin, 2-row header	This jumper can be used to break the supply voltage line to measure the current consumption of a connected Sensor Board. Important: During normal operation, ensure that a jumper is on the “DMM” position as shown in Figure 2.
K2	3-pin header	This jumper selects either the internal or external voltage supply. For the proper position for the jumper, see Figure 3.
K3	8-pin, 2-row right-angle header	This connector can be used to connect the ZMOD4410 in different configurations or to measure the communication lines and voltages on the ZMOD4410 Sensor Board.
K4	14-pin connector	This is the connector for installing the ZMOD4410 Sensor Board on the Communication Board.
K5	2-pin header	This is the connector for an optional external voltage supply (see Figure 3).
D1	Status LED	This LED lights if the Communication Board is powered correctly (see Figure 2).
D2	Status LED	This LED lights if the software sets the trigger pin (see Figure 2).
D3	Status LED	This LED will light with an intensity proportional to the internal voltage supply that was set using the potentiometer (see Figure 2).
X1	Micro USB B-type	This is the micro-USB cable connector for connecting the Communication Board to the user’s computer.
R19	Potentiometer	This potentiometer adjusts the internal supply voltage. The internal supply voltage can be adjusted by rotating the potentiometer with a small screwdriver.
Modul1	DIL socket	This socket can be used to add external components via I <sup>2</sup> C to the Communication Board. For additional instructions, contact Renesas.



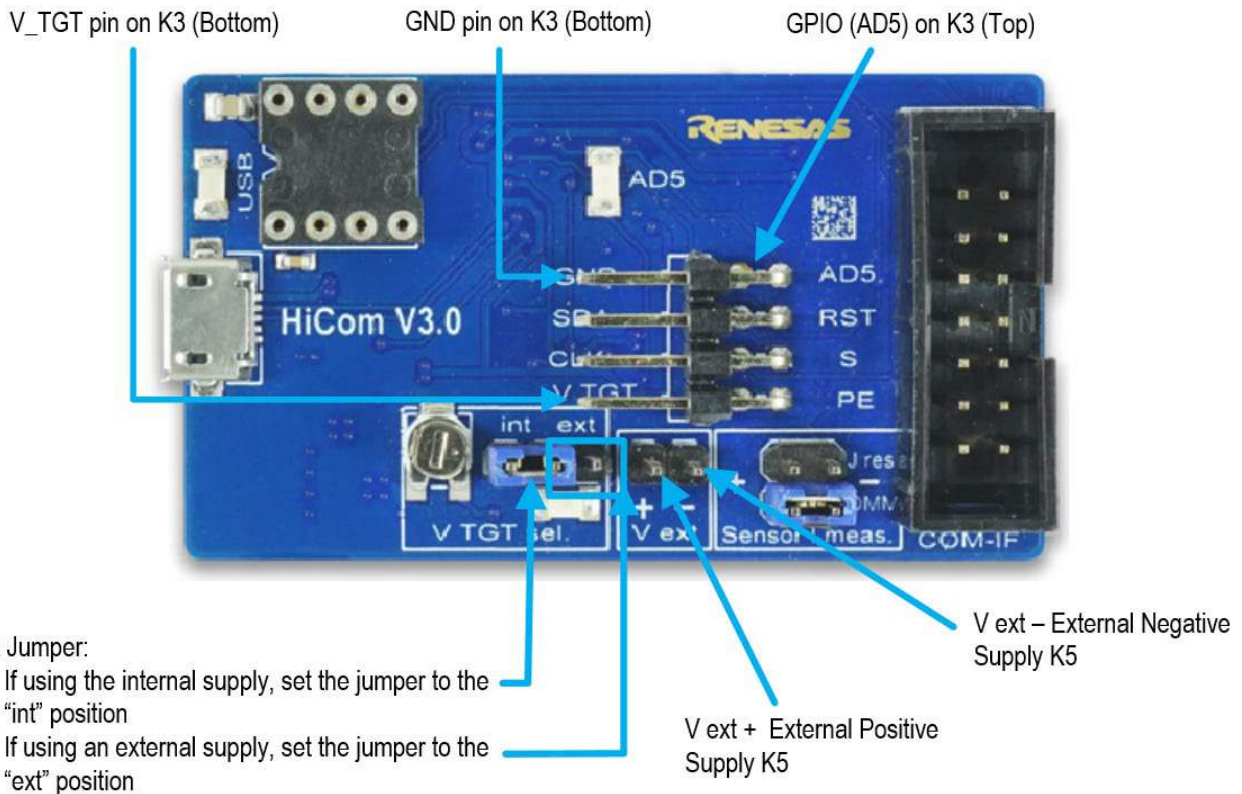

Figure 3. Jumper Settings, Connections, and Test Points on the Communication Board for the Internal or External Supply Voltage

## 2. Usage Guide

When the Gas Sensor Evaluation Software is started, the initial window is displayed as shown in Figure 4. The initial display in all operation modes consists of three blocks:

- Measurement Control
- Signal Analysis
- Plot Visualization

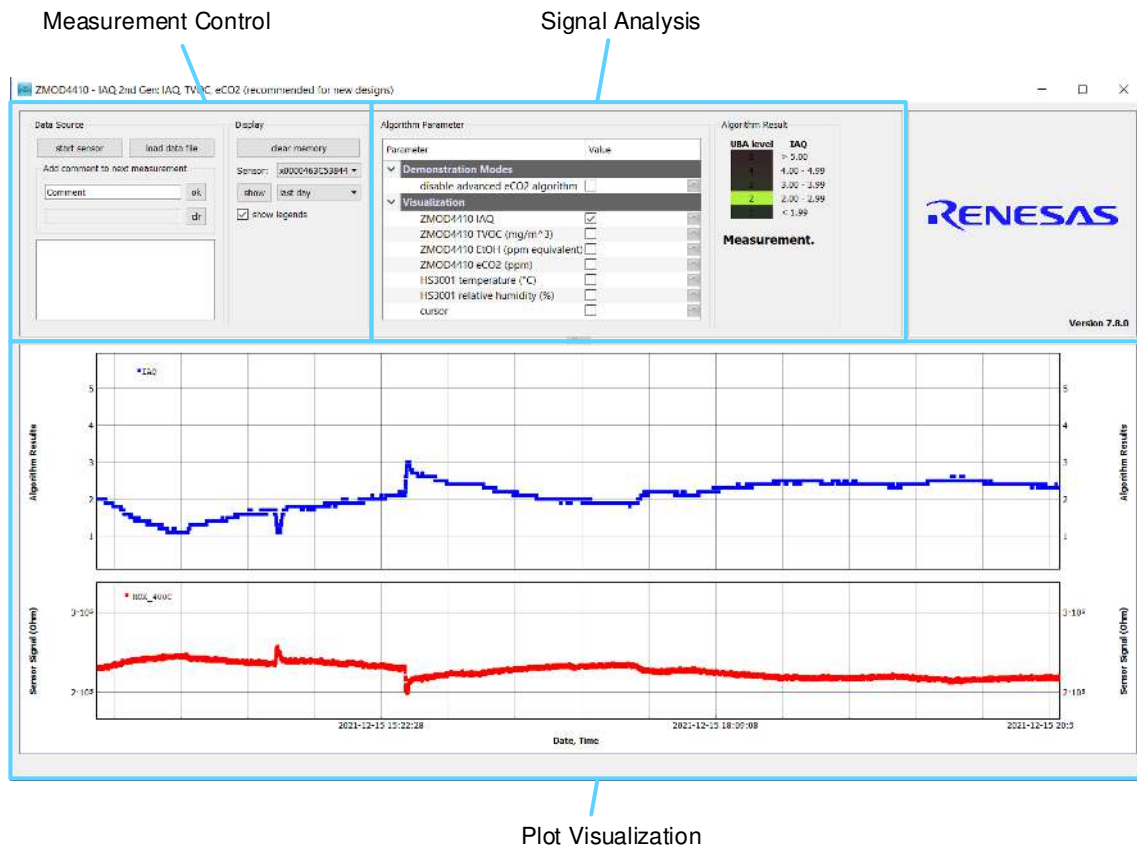

Figure 4. Initial Display for the ZMOD4410 Start-Up

## 2.1 Measurement Control Block

The “Measurement” area of the display allows users to start the ZMOD4410’s gas measurements. When the “start sensor” button is clicked, the button name changes to “stop sensor” and the measurement starts running continuously. The sample and warm-up rates are provided in the *ZMOD4410 Datasheet*.

The results will be saved in a comma-separated file (CSV), which is user-selected via the file and path selection dialog when the sensor is started. This CSV file contains multiple sensor parameters (the sensor tracking number, the production lot number, calibration parameters, etc.) In addition, all raw sensor signals (resistances) for each measurement step and temperature are recorded (e.g., MOX\_INC\_200C, which is the resistance of the MOx sensor at 200°C) as well as the ambient temperature (°C) and relative humidity (%) given by the HS3xxx or HS40xx sensor. All this additional information and parameters are usually used for debugging and validation only. The focus should be drawn to the relevant parameters such as the algorithm results.

A comment (e.g., “Start test”) can be added to the data entry by adding a text string to the “Add comment to next measurement” field and then clicking the “OK” button. If a measurement is already in progress, the comment will be added to the next measurement. The comments will be displayed in the plot and will be saved in the CSV result file. This facilitates tracking the user’s experimental investigations. Below this entry field, a small window with a log field shows all events logged.



## 2.2 Signal Analysis Block and Options

Depending on the operation mode, the user will see slightly different options. The available user options are described in Table 2 for all measurement modes.

**Table 2. Analysis Tab User Options**

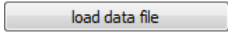
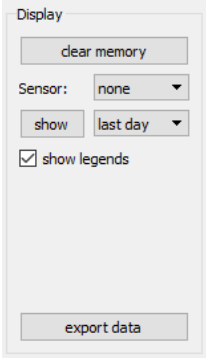
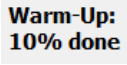
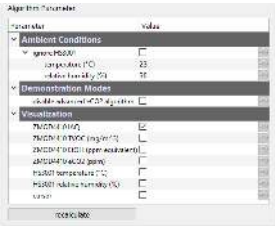
Display Section	Button/Action	Description
Data Source		This option allows the loading of previously recorded csv files into the EVK software when having the same csv file column structure. This feature can also compare results of ZMOD4410 EVK software with ZMOD4410 firmware csv files. It also allows processing of previously recorded csv files with the latest algorithms. For this usage, it is not necessary to connect the ZMOD4410 Evaluation Kit hardware.
Display		<p>The “clear memory” button will delete all current data from the plots (memory). The data in the measurement file will remain.</p> <p>If measurements are acquired simultaneously for multiple ZMOD4410 gas sensors, the measurement results file can contain data from different sensors. In the “Sensor” drop-down menu, the user can choose a sensor to display by selecting the unique sensor identification number.</p> <p>The drop-down menu adjacent to the “show” button provides options for selecting the time period for showing the recent history or the complete data. Click the “show” button to apply new settings to the plots.</p> <p>In addition, a legend for the plot visualization can be activated or deactivated. The “export data” can be used to export a data file, which was loaded and post-processed with the latest GUI algorithms.</p>
Algorithm Result		The first measurements of the algorithm will be taken for sensor warm-up (for more information, see the <i>ZMOD4410 Datasheet</i> ). This field indicates how much time has been completed during this period. Raw sensor signals and algorithm results are shown on the plots during this time, but full algorithm performance is only given after warm-up. Note that this does not cover the full stabilization of the sensor module but rather covers only the first minutes during startup. The actual stabilization can take longer (up to 48h).
Algorithm Parameters for “IAQ 2 <sup>nd</sup> Gen”		<p>For sensor operation, temperature or humidity compensation are not required; however, for best performance temperature and humidity compensation are recommended. This is enabled by default in case a temperature and humidity sensor is connected. The Renesas HS temperature/humidity sensor is added from Daughter Board revision R 2-2 onwards; alternatively, an HS3xxx or HS40xx sensor can be connected via I2C.</p> <p>If a temperature or humidity sensor is not found or ignored, the settings for the parameters can be set manually in this field.</p> <p>The Visualization field supports changes to the plot for the following options:</p> <ul style="list-style-type: none"> <li>IAQ rating according to UBA using the ZMOD4410</li> <li>TVOC concentration (in mg/m3) using the ZMOD4410</li> <li>Equivalent Ethanol (EtOH) concentration (in ppm) using the ZMOD4410</li> <li>Estimation of Carbon Dioxide (eCO<sub>2</sub>) concentration (in ppm) using the ZMOD4410</li> <li>Temperature (in °C) using the HS sensor</li> <li>Relative Humidity (in %) using the HS sensor</li> <li>Activate the cursor</li> </ul> <p>Renesas’ patented smart algorithm provides eCO<sub>2</sub> readings with high accuracy when activated (default). However, for demonstration reasons it may be useful to disable the eCO<sub>2</sub> algorithm in the section “Demonstration Modes” to see very fast CO<sub>2</sub> changes directly related to the VOC level.</p>

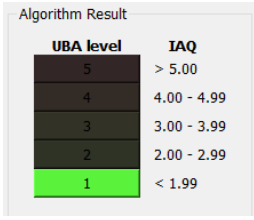
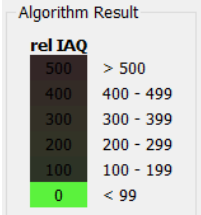
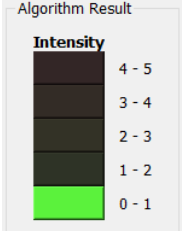
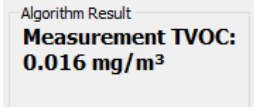
Display Section	Button/Action	Description
Algorithm Results "IAQ 2 <sup>nd</sup> Gen"		<p>After the stabilization measurements, the "Algorithm Result" field shows a colored bar representing the results from the algorithm. The IAQ rating from the Federal German Environmental Agency (UBA level) and the corresponding IAQ rating are shown.</p> <p>For more information on IAQ, UBA, and eCO<sub>2</sub>, refer to the <i>ZMOD4410 White Paper – Overview of TVOC and Indoor Air Quality</i> and the <i>ZMOD4410 Application Note – Estimating Carbon Dioxide</i>.</p>
Algorithm Result "Relative IAQ"		<p>After the stabilization measurements, the "Algorithm Result" field shows a colored bar representing the results from the Relative IAQ algorithm.</p> <ul style="list-style-type: none"> <li>▪ 0 to 100 Improvement in Air Quality (air gets more clean)</li> <li>▪ 100 No change in Air Quality</li> <li>▪ 100 to 500 Degradation in Air Quality (air gets more polluted)</li> </ul>
Algorithm Result "Sulfur Odor Discrimination"		<p>This method of operation uses a highly trained AI Neural Network to identify bad sulfur odors. The algorithm output is classified as "acceptable" and "bad" with an intensity indicator ranging from 1 (clean air) to 5 (very strong).</p>
Algorithm Result "PBAQ"		<p>The PBAQ operation mode complies with typical Public Building Air Quality standards. It focuses on high accurate TVOC concentrations in the typical indoor environments and is given in mg/m<sup>3</sup>. If a ppm rating is needed, this can be active in the plot and is also and logged in the csv output file.</p>

### 2.3 Plot Visualization Block

The lower half of the display provides a visualization of the data. This shows the plots for the options selected in the algorithm parameter field, as well as the raw sensor output signal (in Ω). For additional information, including application notes, white papers, and blogs, visit the [ZMOD4410](https://www.renesas.com/en/products/evaluation-kits/zmod4410) product page.

### 2.4 Error Codes

Due to some interference between the FTDI, Windows operation system, and the computer's USB driver, a startup problem may occur on some systems if the EVK is started on a USB 3 port. Renesas recommends using a USB 2.x port for the first initial startup of the EVK. The Gas Sensor Evaluation Software has a debug log file that can be found under: "C:\Users\USERNAME\AppData\Local\GasSensorEvaluation.log". This file may provide more information on the nature of the error. When requesting technical support for the ZMOD EVK please provide this file. Other common error messages are explained in Table 3.

*Note:* Always make sure the downloaded zip-file is unzipped before starting the executable file.

**Table 3. Most Common Error Messages**

Error Code	Description and Solution
Cannot connect to hardware! Have you installed the FTDI D2XX driver? Is the hardware connected?	Please confirm that the FTDI driver is installed correctly properly and the hardware is connected. Start the Renesas <i>GasSensorEvaluation_Installer</i> Software for a repair option. Note that during the initial startup of the EVK software the HiCom must be connected to the computer.

<b>Error Code</b>	<b>Description and Solution</b>
Cannot write data file!	During the measurement, the csv data file could not be edited (e.g., file protection, missing drive)
Data not valid The data in file %s is not valid!	A csv file was loaded for analysis, which does not contain the necessary data.
Failed to execute script GasSensorEvaluation	Please confirm that the FTDI driver is installed correctly properly and the hardware is connected. Start the Renesas <i>GasSensorEvaluation_Installer</i> Software for a repair option. Note that during the initial startup of the EVK software the HiCom must be connected to the computer.
Product not supported / Wrong Device	Please use a ZMOD4410 Sensor Board.
POR event detected during measurement validation	The ZMOD4410 sensor board was restarted during the measurement (e.g., problems with power supply, loose contacts, electromagnetic issue, ESD).
Wrong data file! Data file has not the right columns to store the measurements. Please create a new data file.	The EVK software tried to write measurement data to an existing csv file, which columns structure does not fit the recent software (EVK software version conflict).

### 3. Schematics

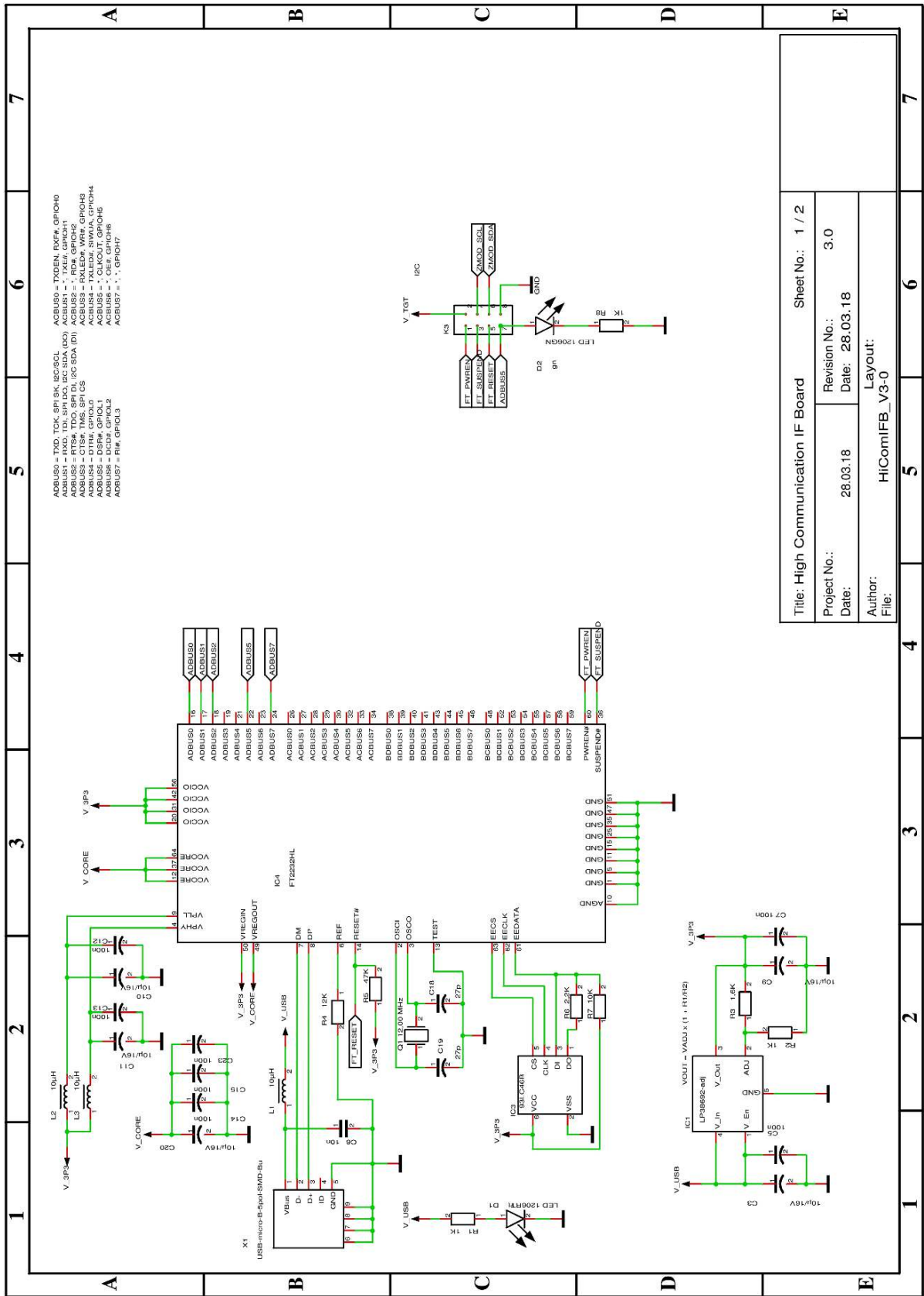

Figure 5. Communication Board Schematic – Page 1

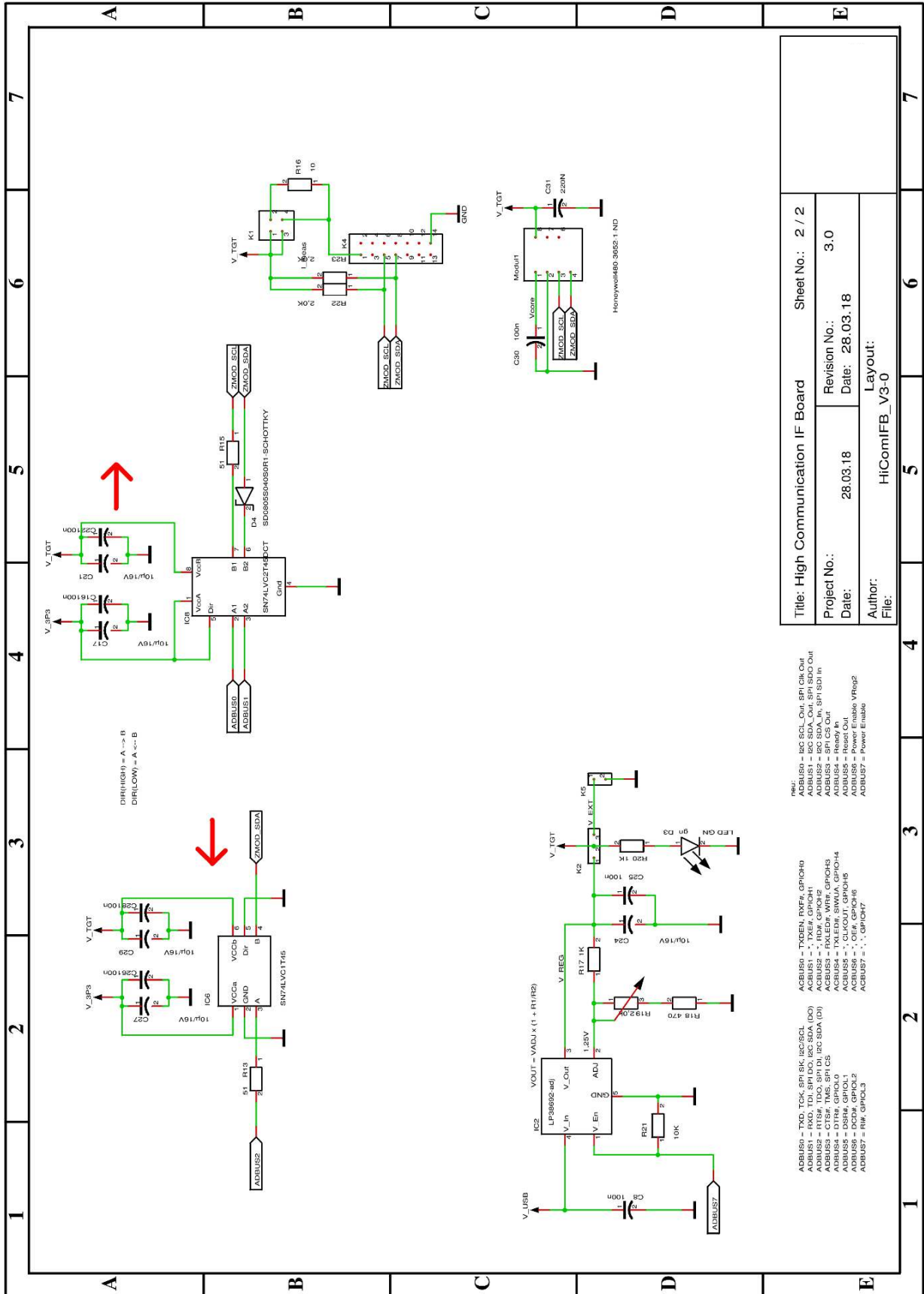

Figure 6. Communication Board Schematic – Page 2

Title: High Communication IF Board		Sheet No.: 2 / 2
Project No.: 28.03.18	Revision No.: 3.0	
Date: 28.03.18	Date: 28.03.18	
Author: HiComIFB_V3-0	Layout: HiComIFB_V3-0	

new:  
 ABBUS0 = I2C SCL\_Out, SPI CLK\_Out  
 ABBUS1 = I2C SDA\_In, SPI SDI\_In  
 ABBUS2 = SPI CS\_Out  
 ABBUS3 = Ready\_Out  
 ABBUS4 = Power Enable\_VReg2  
 ABBUS7 = Power Enable

new:  
 ABBUS0 = TXDn, TXE, SPI BK, I2C/SCL (D0)  
 ABBUS1 = RTSP, TXD, SPI DI, I2C SDA (D1)  
 ABBUS2 = CTS#, TMS, SPI CS  
 ABBUS3 = TXLED#, WTRF, GPIOH3  
 ABBUS4 = TXDn, TXE, SPI BK, I2C/SCL (D0)  
 ABBUS5 = DS1M, GPIOH4  
 ABBUS6 = DCDA, GPIOH2  
 ABBUS7 = RW, GPIOH3





## 4. Bill of Materials (BOM)

Table 4. Communication Board BOM

Position	Name	Description	Package
1	C3	10 $\mu$ F/16V	0805
2	C5	100nF	0603
3	C6	10nF	0805
4	C7	100nF	0603
5	C8	100nF	0603
6	C9	10 $\mu$ F/16V	0805
7	C10	10 $\mu$ F/16V	0805
8	C11	10 $\mu$ F/16V	0805
9	C12	100nF	0603
10	C13	100nF	0603
11	C14	100nF	0603
12	C15	100nF	0603
13	C16	100nF	0603
14	C17	10 $\mu$ F/16V	0805
15	C18	27pF	0603
16	C19	27pF	0603
17	C20	10 $\mu$ F/16V	0805
18	C21	10 $\mu$ F/16V	0805
19	C22	100nF	0603
20	C23	100nF	0603
21	C24	10 $\mu$ F/16V	0805
22	C25	100nF	0603
23	C26	100nF	0603
24	C27	10 $\mu$ F/16V	0805
25	C28	100nF	0603
26	C29	10 $\mu$ F/16V	0805
27	C30	100nF	0603
28	C31	220nF	0805
29	D1	LED 1206RT	1206-DIODE
30	D2	LED 1206GN	1206-DIODE
31	D3	LED 1206GN	1206-DIODE
32	D4	SD0805S040S0R1-SCHOTTKY	0805-DIODE
33	IC1	LP38692-adj	SOT-223-5
34	IC2	LP38692-adj	SOT-223-5

Position	Name	Description	Package
35	IC3	93LC46B	SOT23-6
36	IC4	FT2232HL	LQFP64
37	IC6	SN74LVC1T45	SOT23-6
38	IC8	SN74LVC2T45DCT	SSOP8_0,65
39	K1	I_meas	2X02
40	K2	Select	1X03
41	K3	K2X4	2X04-90
42	K4	K2X7	LH-14
43	K5	V_EXT	1X02
44	L1	10μH	1210
45	L2	10μH	1210
46	L3	10μH	1210
47	Modul1	Honeywell480-3652-1-ND	DIL8 SMD SOCKET
48	Q1	12.00MHz	QUARZ-ABM3
49	R1	1kΩ	0805
50	R2	1kΩ	0805
51	R3	1.6kΩ	0805
52	R4	12kΩ	0805
53	R5	47kΩ	0805
54	R6	2.2kΩ	0805
55	R7	10kΩ	0805
56	R8	1kΩ	0805
57	R13	51Ω	0805
58	R15	51Ω	0805
59	R16	10Ω	0805
60	R17	1kΩ	0805
61	R18	470Ω	0805
62	R19	2.0kΩ	TRIMMER-3142SERIES
63	R20	1kΩ	0805
64	R21	10kΩ	0805
65	R22	2.0kΩ	0805
66	R23	2.0kΩ	0805
67	X1	USB-micro-B-5pol-SMD-Bu	USB-MICRO_TYPB_AMTEK

**Table 5. Sensor Board BOM**

Position	Name	Quantity	Description	Package
1	C1	1	1μF 25V X5R 20% BF:0402	402
2	C2, C3	2	100nF 25V X5R 20% BF:0402	402
3	R3	1	RES 10kOhm 1% TK100	402
4	U1	1	ZMOD4410 Indoor Air Quality Sensor	LGA12
5	U2	1	HS Temperature and Humidity Sensor	LGA6
6	X1	1	14 Pin Connector	TH14

**Table 6. PIN Configuration on Connector X1**

Pin Number	Pin Description
1	VDD
2	N.C.
3	N.C.
4	N.C.
5	SCL
6	RES_N
7	SDA
8	N.C.
9	N.C.
10	INT
11	N.C.
12	N.C.
13	N.C.
14	GND

## 5. Board Layout

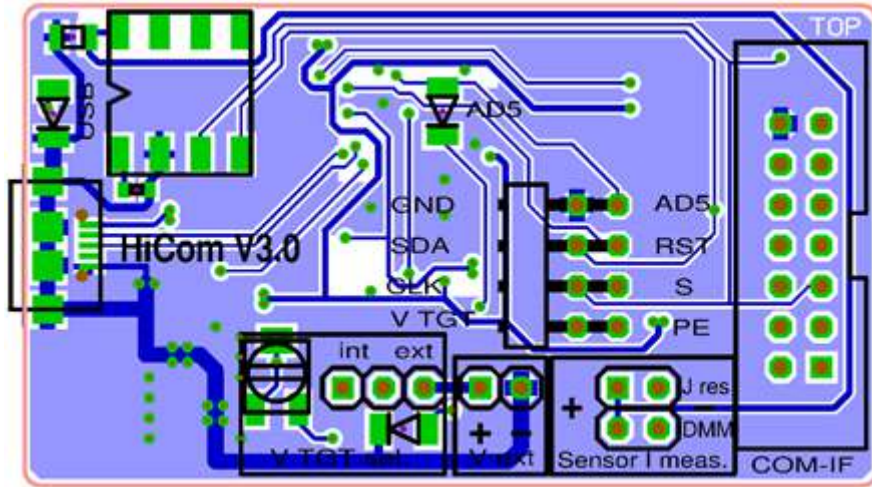

Figure 8. HiCom Communication Board Layout – Top Layer

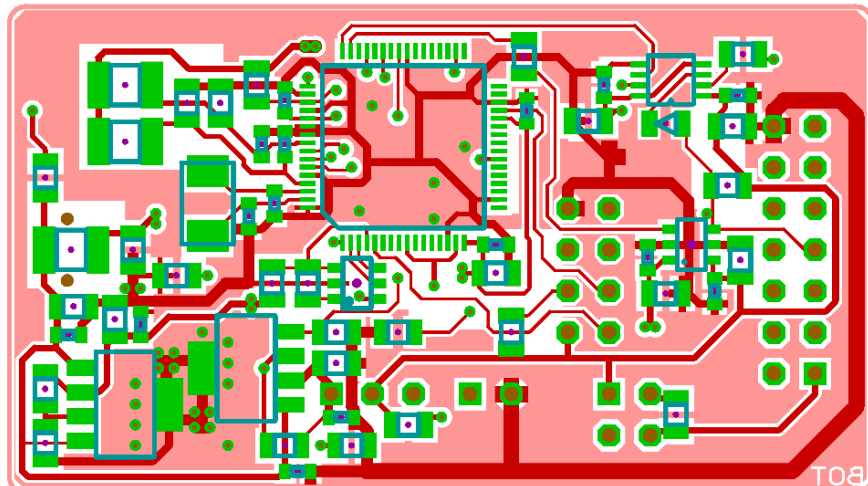

Figure 9. HiCom Communication Board Layout – Bottom Layer

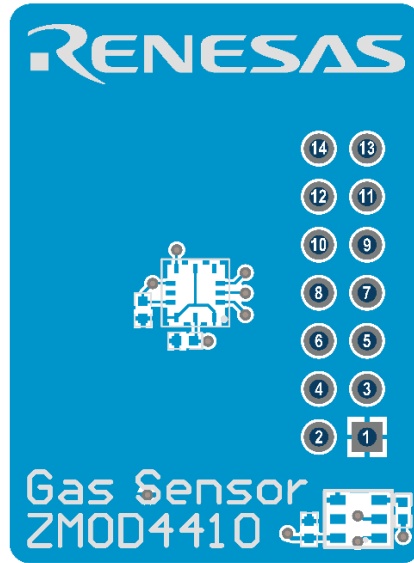

Figure 10. Sensor Board Layout – Top Layer with PIN Configuration on Connector X1

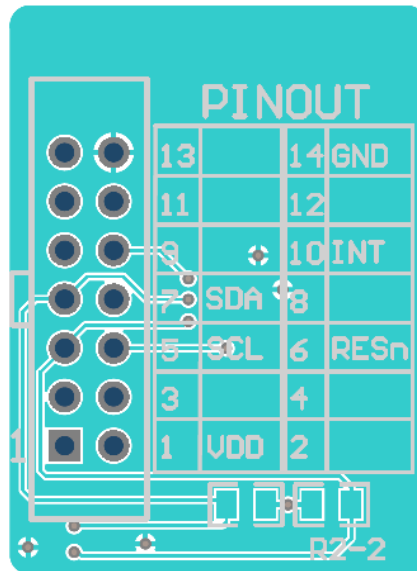

Figure 11. Sensor Board Layout – Bottom Layer

## 6. Ordering Information

Part Number	Description
ZMOD4410-EVK-HC	ZMOD4410 Evaluation Kit including the ZMOD4410 Sensor Board, HiCom Communication Board (USB Interface), and Micro-USB Cable. The Gas Evaluation Software is available for download free of charge on <a href="#">ZMOD4410 EVK</a> product page.
ZMOD4410-EVK-HC-WP	ZMOD4410 Evaluation Kit including the water- and dust proof ZMOD4410 Sensor Board, HiCom Communication Board (USB Interface), and Micro-USB Cable. The Gas Evaluation Software is available for download free of charge on <a href="#">ZMOD4410 EVK</a> product page.

## 7. Revision History

Revision	Date	Description
1.08	Mar 10, 2023	<ul style="list-style-type: none"> <li>Updated to include a broader definition of Public Building Air Quality (PBAQ)</li> </ul>
1.07	Jan 27, 2023	<ul style="list-style-type: none"> <li>Added WELL method of operation.</li> </ul>
1.06	Sep 8, 2022	<ul style="list-style-type: none"> <li>Updated Operation Modes with "Relative IAQ" (replacing "Odor") and RH/T compensation</li> <li>Update with Software Installer</li> <li>Reformatted to the latest template</li> </ul>
-	Dec 17, 2021	<ul style="list-style-type: none"> <li>Added IAQ 2<sup>nd</sup> Gen ULP method of operation</li> <li>Updated web links</li> </ul>
-	Nov 13, 2020	Updated to support the Waterproof version of the EVK.
-	Jun 3, 2020	<ul style="list-style-type: none"> <li>Added IAQ 2<sup>nd</sup> Gen method of operation.</li> <li>Added Sulfur odor Discrimination method of operation.</li> <li>Updated the Gas Sensor Evaluation software version.</li> <li>Updated the link to the FTDI driver.</li> <li>Updated the stabilization time.</li> <li>Added Error Codes.</li> </ul>
-	Nov 1, 2018	Updated with Low Power operation mode.
-	Sep 25, 2018	Updated with Odor operation mode.
-	May 19, 2018	Initial release.



## IMPORTANT NOTICE AND DISCLAIMER

RENESAS ELECTRONICS CORPORATION AND ITS SUBSIDIARIES (“RENESAS”) PROVIDES TECHNICAL SPECIFICATIONS AND RELIABILITY DATA (INCLUDING DATASHEETS), DESIGN RESOURCES (INCLUDING REFERENCE DESIGNS), APPLICATION OR OTHER DESIGN ADVICE, WEB TOOLS, SAFETY INFORMATION, AND OTHER RESOURCES “AS IS” AND WITH ALL FAULTS, AND DISCLAIMS ALL WARRANTIES, EXPRESS OR IMPLIED, INCLUDING, WITHOUT LIMITATION, ANY IMPLIED WARRANTIES OF MERCHANTABILITY, FITNESS FOR A PARTICULAR PURPOSE, OR NON-INFRINGEMENT OF THIRD PARTY INTELLECTUAL PROPERTY RIGHTS.

These resources are intended for developers skilled in the art designing with Renesas products. You are solely responsible for (1) selecting the appropriate products for your application, (2) designing, validating, and testing your application, and (3) ensuring your application meets applicable standards, and any other safety, security, or other requirements. These resources are subject to change without notice. Renesas grants you permission to use these resources only for development of an application that uses Renesas products. Other reproduction or use of these resources is strictly prohibited. No license is granted to any other Renesas intellectual property or to any third party intellectual property. Renesas disclaims responsibility for, and you will fully indemnify Renesas and its representatives against, any claims, damages, costs, losses, or liabilities arising out of your use of these resources. Renesas' products are provided only subject to Renesas' Terms and Conditions of Sale or other applicable terms agreed to in writing. No use of any Renesas resources expands or otherwise alters any applicable warranties or warranty disclaimers for these products.

(Disclaimer Rev.1.0 Mar 2020)

### Corporate Headquarters

TOYOSU FORESIA, 3-2-24 Toyosu,  
Koto-ku, Tokyo 135-0061, Japan  
[www.renesas.com](http://www.renesas.com)

### Contact Information

For further information on a product, technology, the most up-to-date version of a document, or your nearest sales office, please visit:  
[www.renesas.com/contact/](http://www.renesas.com/contact/)

### Trademarks

Renesas and the Renesas logo are trademarks of Renesas Electronics Corporation. All trademarks and registered trademarks are the property of their respective owners.