

TERMINALS TO BE ORIENTED AND LOADED INTO THE HOUSING AS SHOWN BELOW

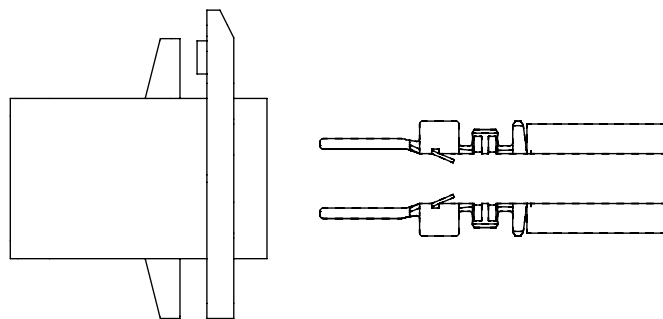

NOTES:

1. MATERIAL: POLYESTER, UL94V-0, COLOR: BLACK.
2. PRODUCT CONFORMS TO PRODUCT SPECIFICATION PS-45779-001.
3. USES MALE CRIMP TERMINALS SERIES 45627.
4. PART MATES WITH MOLEX RECEPTACLE SERIES 45579.
5. PACKAGING: BULK.
6. SEE PAGE 2 OF 2 FOR PANEL CUTOUT DIMENSIONS AND THE ALLOWED PANEL TO PANEL MISALIGNMENT.
7. USE MOLEX EXTRACTION TOOL 63813-1400 TO REMOVE TERMINALS WITHOUT DAMAGING THE PLUG CORE. RELOAD CORE WITH NEW TERMINAL ONLY. REMOVED TERMINAL AFTER EXTRACTION NOT USABLE.

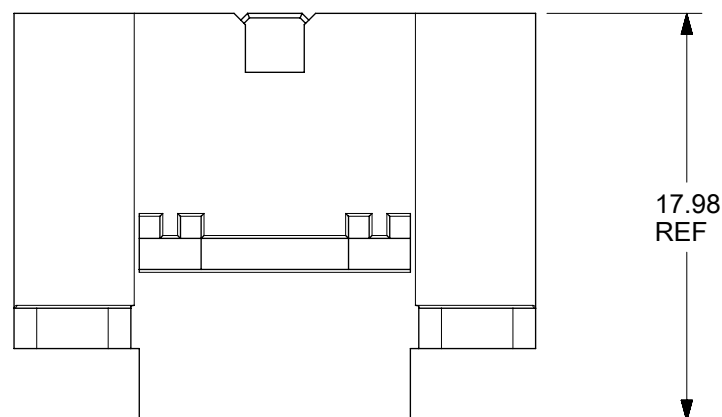
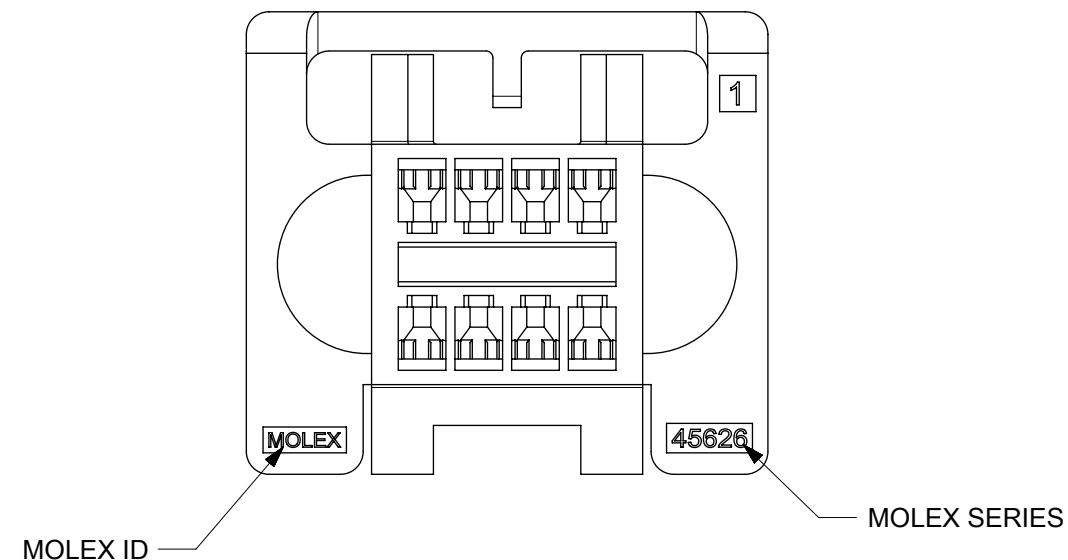
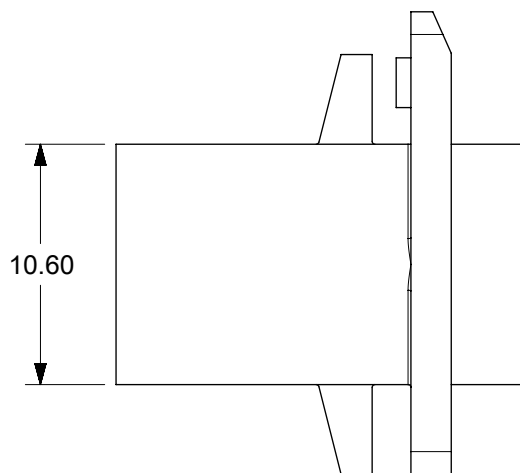
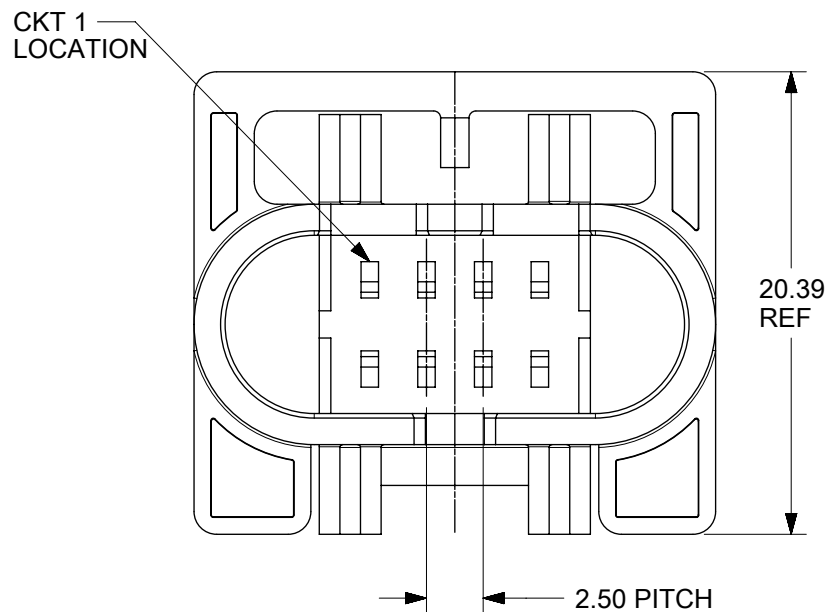
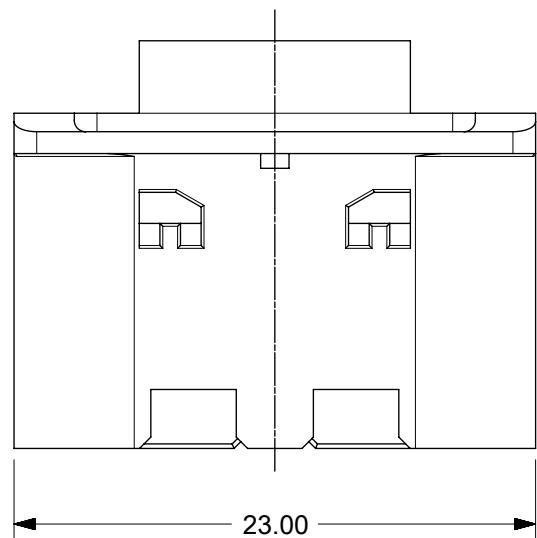

THIS DRAWING CONTAINS INFORMATION THAT IS PROPRIETARY TO MOLEX ELECTRONIC TECHNOLOGIES, LLC AND SHOULD NOT BE USED WITHOUT WRITTEN PERMISSION									
DIMENSION UNITS		SCALE		CURRENT REV DESC:					
MM		3:1		<p><b>molex</b></p> <p>SPOX BMI PLUG HOUSING 8 CIRCUIT REAR ENTRY PANEL MOUNT</p> <p>PRODUCT CUSTOMER DRAWING</p> <p>DOCUMENT NUMBER: SD-45626-008   DOC TYPE: PSD   DOC PART: 001   REVISION: C1</p> <p>MATERIAL NUMBER: 456260008   CUSTOMER: GENERAL MARKET   SHEET NUMBER: 1 OF 2</p>					
GENERAL TOLERANCES (UNLESS SPECIFIED)									
	MM	INCH							
4 PLACES	±								
3 PLACES	±								
2 PLACES	± 0.13								
1 PLACE	± 0.25								
0 PLACES	±								
ANGULAR TOL ± 0.5°				INITIAL REVISION:					
DRAFT WHERE APPLICABLE MUST REMAIN WITHIN DIMENSIONS				THIRD ANGLE PROJECTION		DRAWING		SERIES	
				B-SIZE		45626			

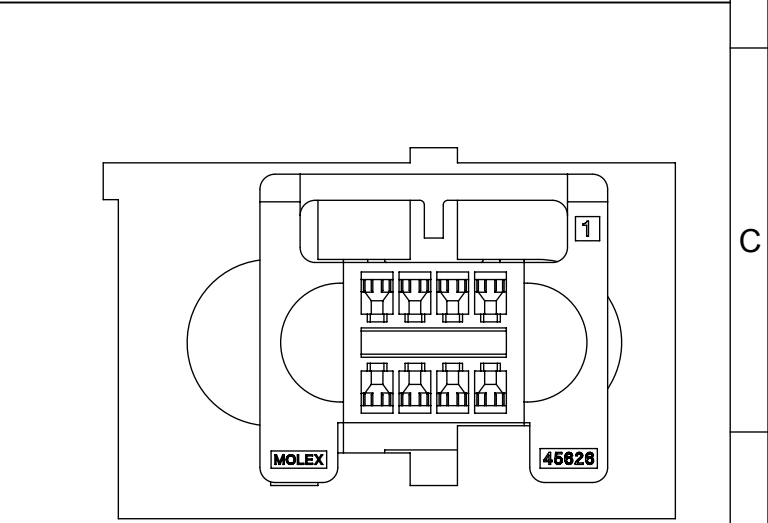
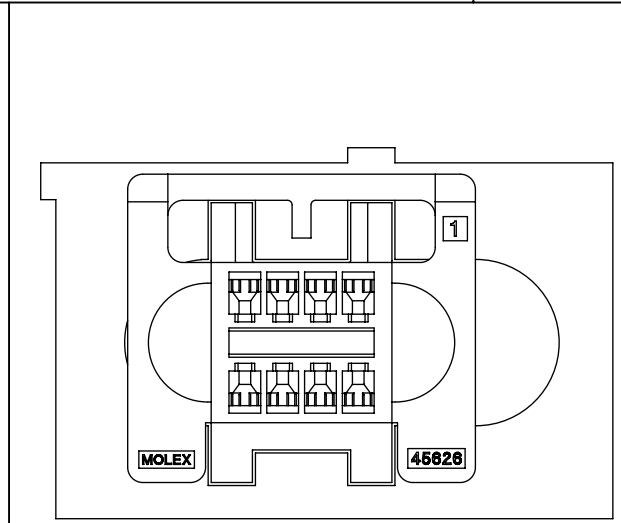
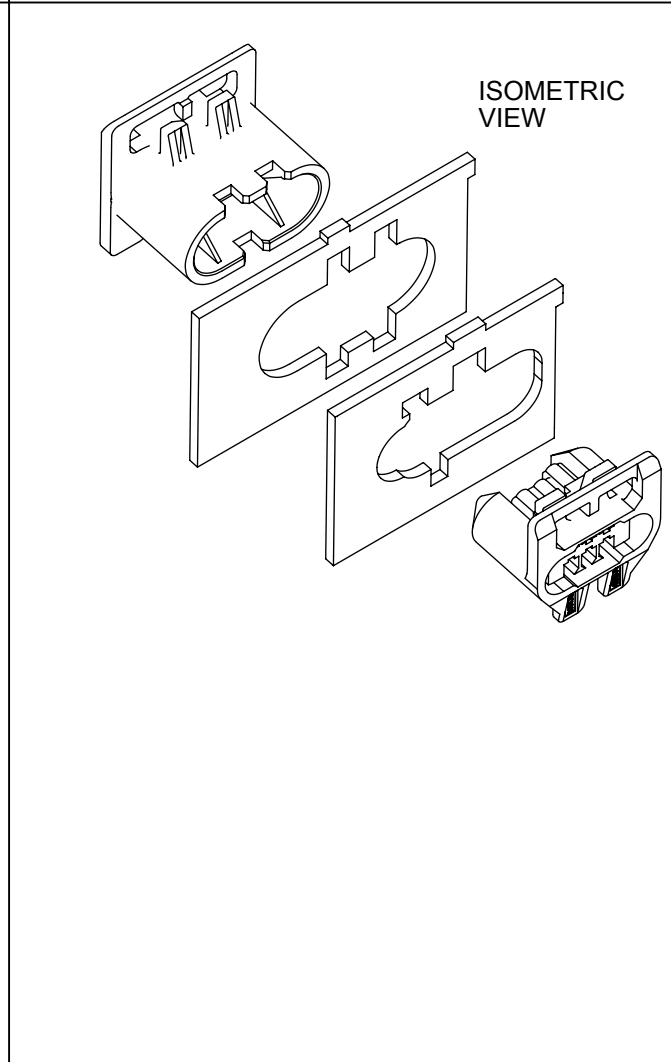
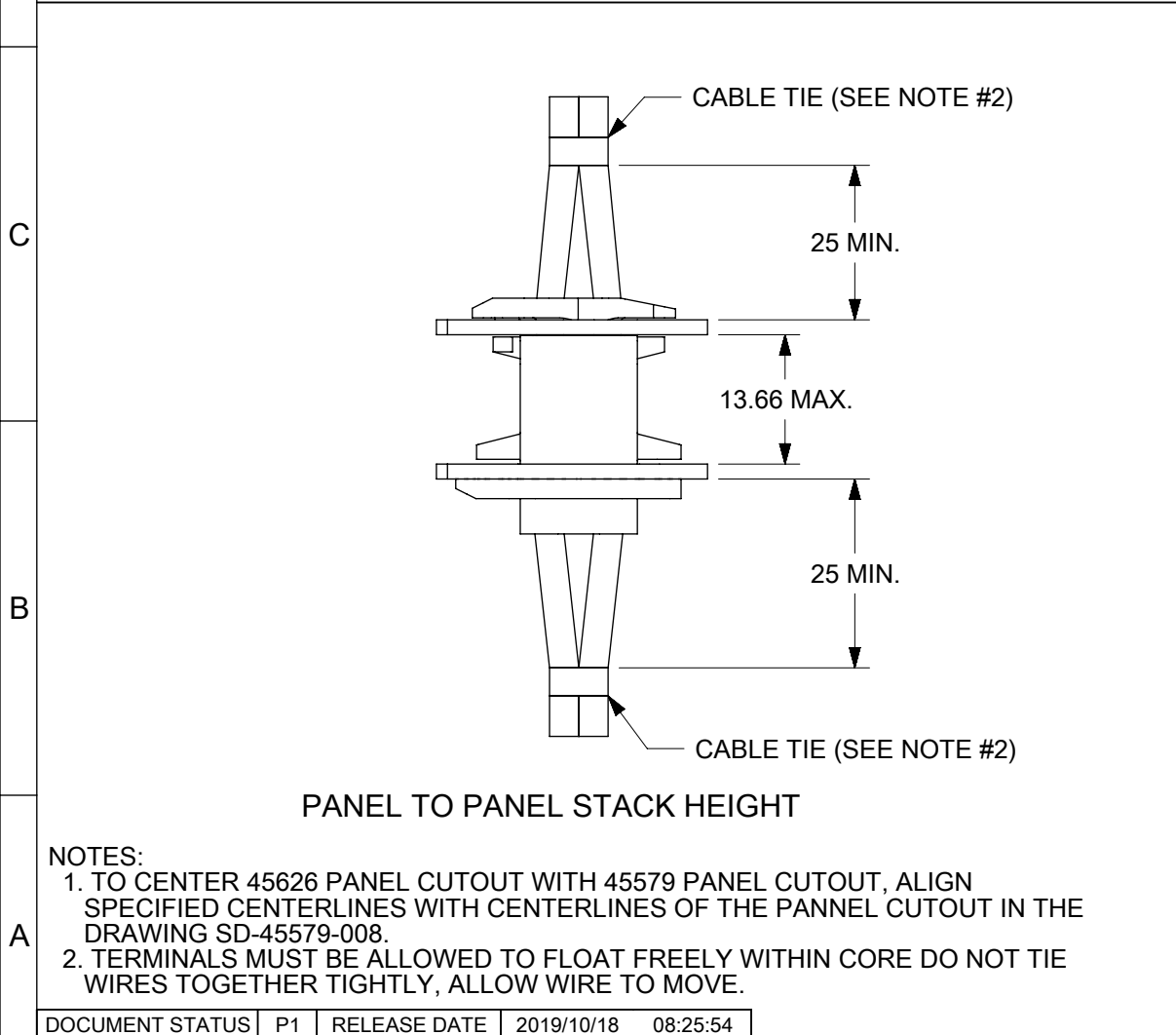
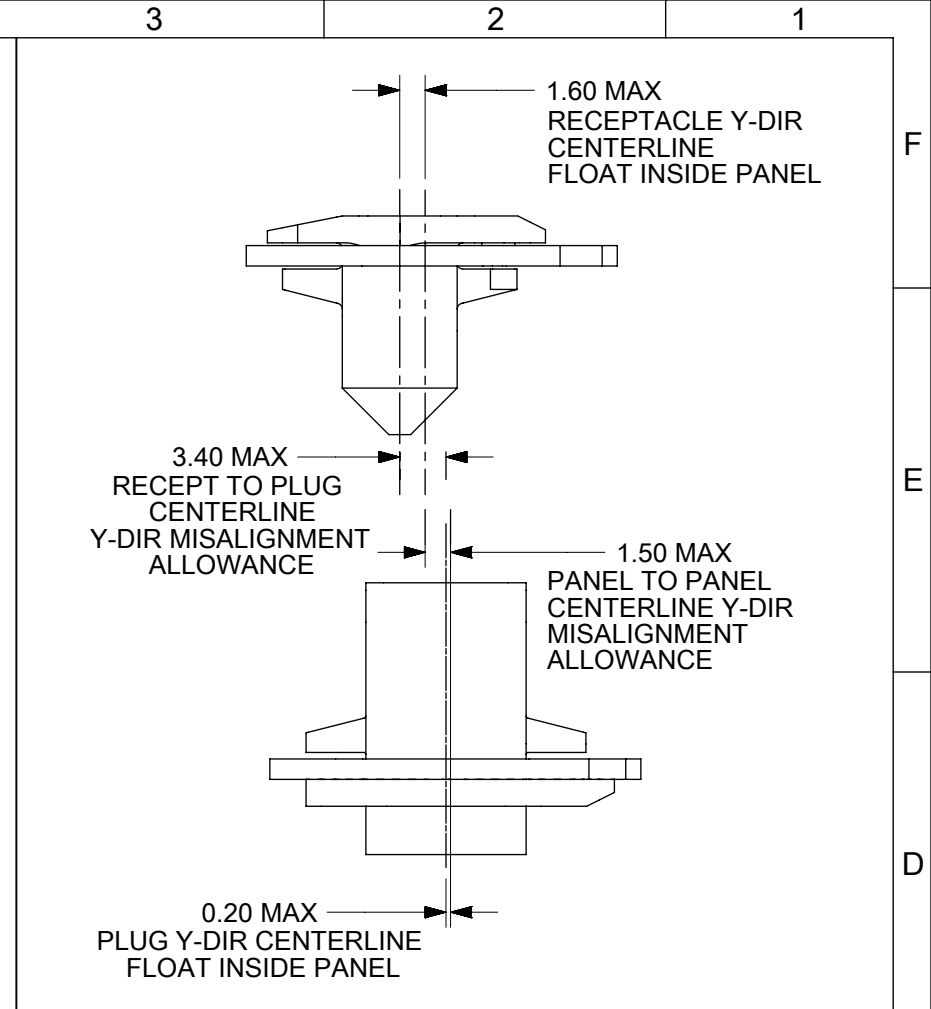
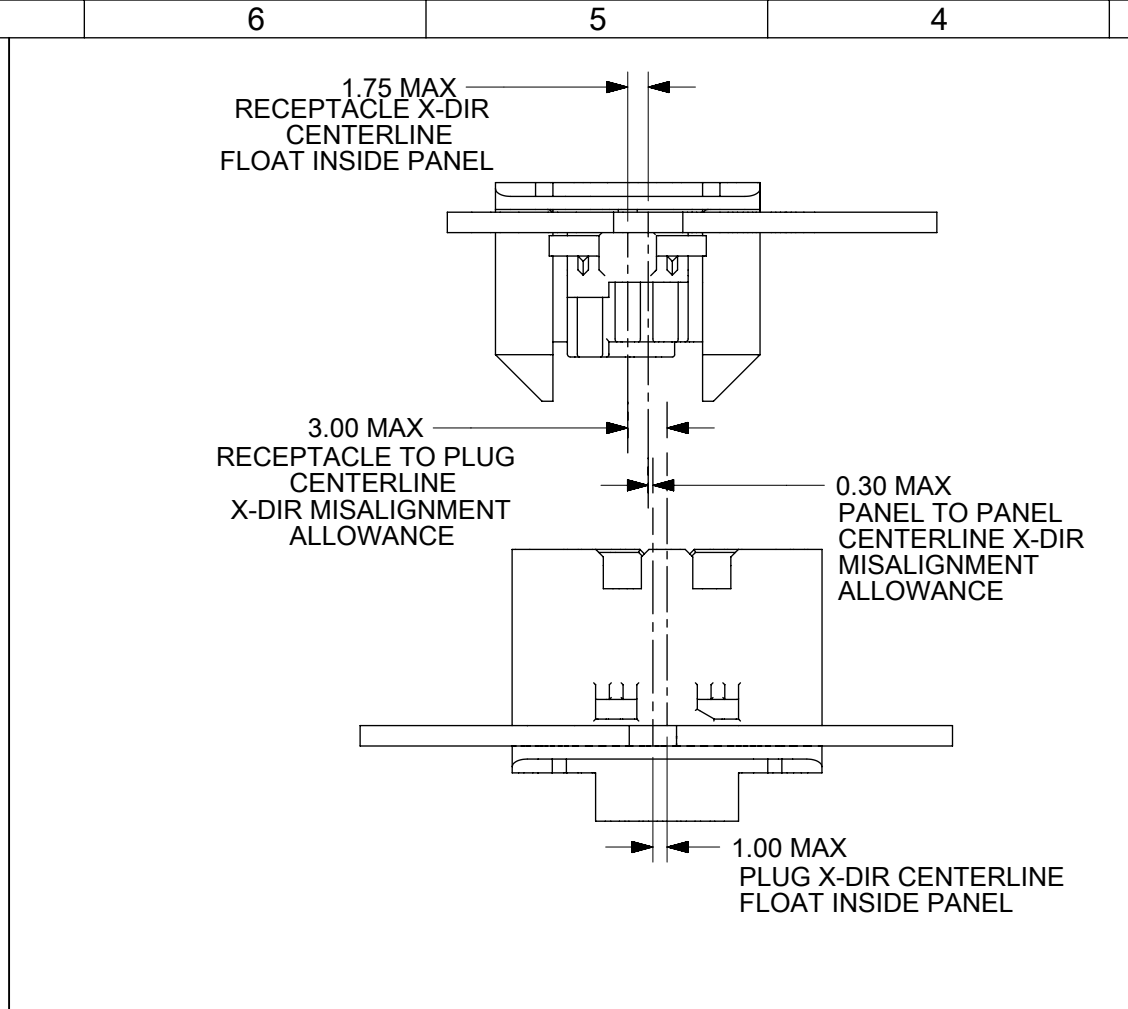
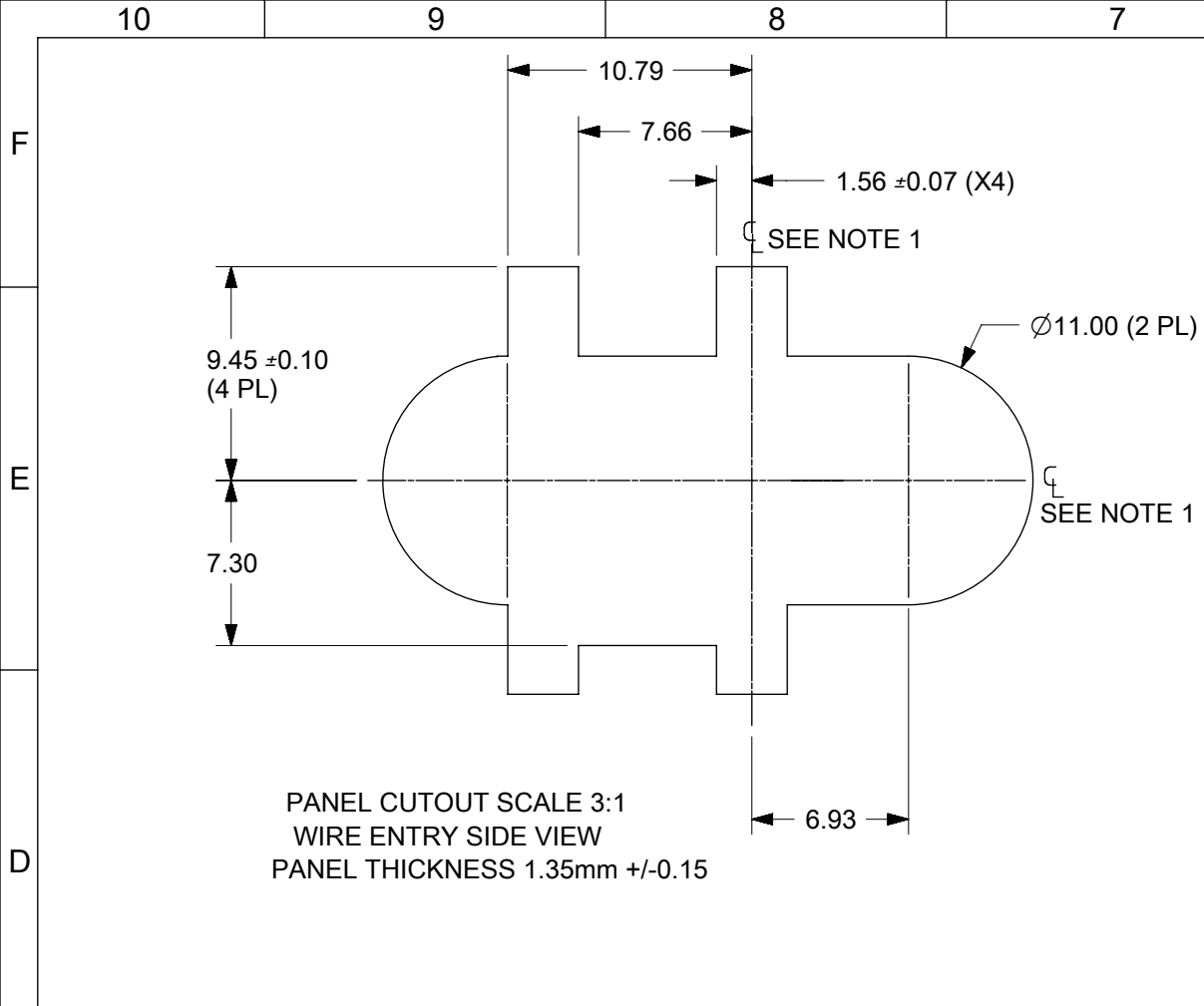

THIS DRAWING CONTAINS INFORMATION THAT IS PROPRIETARY TO MOLEX ELECTRONIC TECHNOLOGIES, LLC AND SHOULD NOT BE USED WITHOUT WRITTEN PERMISSION											
DIMENSION UNITS		SCALE		CURRENT REV DESC:							
MM		3:1									
GENERAL TOLERANCES (UNLESS SPECIFIED)				EC NO: 625546							
4 PLACES ±		±		DRWN: RLALSANGI				2018/02/15			
3 PLACES ±		±		CHK'D: ISHWARG				2019/10/18			
2 PLACES ±		0.13 ±		APPR: ISHWARG				2019/10/18			
1 PLACE ±		0.25 ±		INITIAL REVISION:							
0 PLACES ±		±		DRWN:							
ANGULAR TOL ±		0.5°		APPR: JCOMERCI				2009/08/28			
DRAFT WHERE APPLICABLE MUST REMAIN WITHIN DIMENSIONS				THIRD ANGLE PROJECTION		DRAWING		SERIES		MATERIAL NUMBER	
				B-SIZE		45626		456260008		CUSTOMER	
								GENERAL MARKET		SHEET NUMBER	
										2 OF 2	

**molex**

SPOX BMI PLUG HOUSING  
8 CIRCUIT REAR ENTRY PANEL MOUNT

PRODUCT CUSTOMER DRAWING

DOCUMENT NUMBER: SD-45626-008  
DOC TYPE: PSD  
DOC PART: 001  
REVISION: C1