

REVISIONS					
REV	ECO	DESCRIPTION	DATE	BY	APPR
A1	-	RELEASE NEW DRAWING	15JUN18	SULLEN	TOMMY
A2	-	REVISED DRAWING	10JUL20	JHEAD	DH

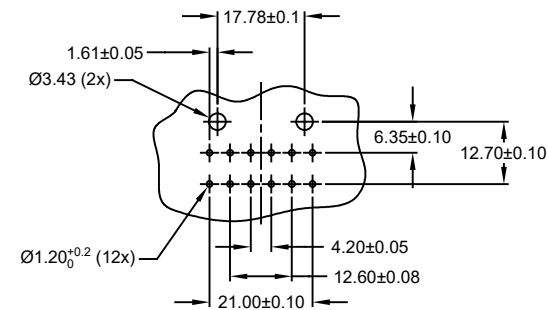
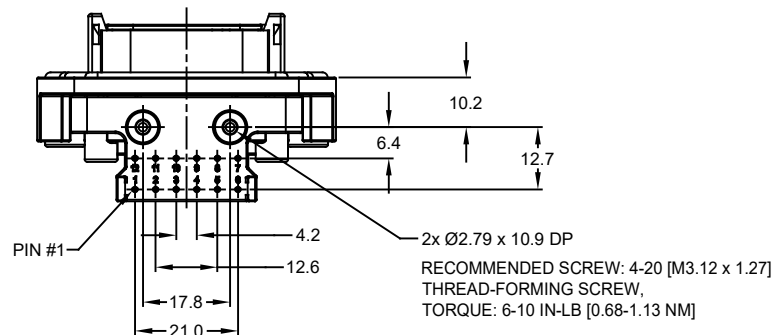
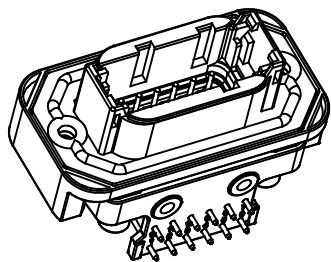
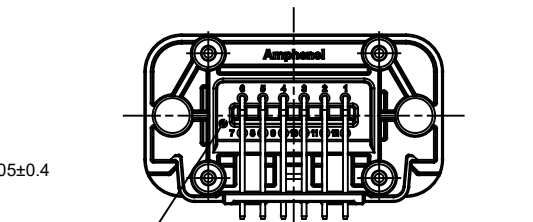
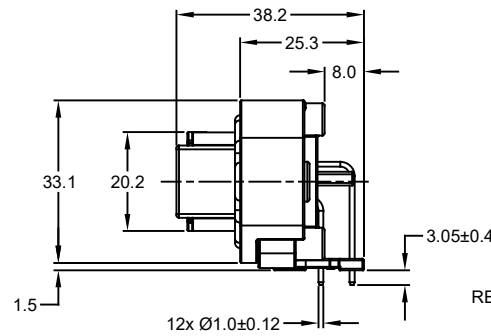
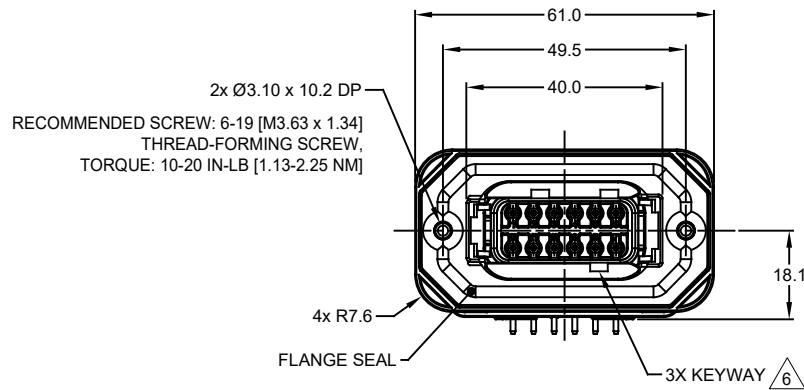

RECOMMENDED PCB LAYOUT  
VIEW FROM COMPONENTS  
SIDE OF PCB

NOTES: UNLESS OTHERWISE SPECIFIED

- MATERIAL:  
HOUSING: THERMOPLASTIC, GREY  
SEAL: SILICONE RUBBER  
CONTACT: COPPER ALLOY
- CONTACT PLATING: SEE SHEET 2
- MODIFICATIONS: FLANGE; RA PCB MOUNT
- SPECIFICATIONS:  
4.1 CURRENT RATING: 7.5 AMPS  
4.2 OPERATING TEMPERATURE: -55°C TO +125°C  
4.3 DIELECTRIC WITHSTANDING VOLTAGE: LESS THAN 2 MILLIAMPS CURRENT LEAKAGE @ 1500 VOLTS AC  
4.4 INSULATION RESISTANCE: 1000 MEGOHMS MIN @ 25°C  
4.5 MOISTURE RESISTANCE: IP67 ( MATED CONDITION )  
4.6 MATING CYCLE DURABILITY: 100 CYCLES  
4.7 RoHS COMPLIANT

- MATING PART: ATM06-12SX\*  
( X = A,B,C,D KEYS ; \* = MODIFICATIONS AND COLORS )  
△ SEE SHEET 2 FOR OTHER KEY ARRANGEMENTS AND COLORS
- ALL DIMENSIONS ARE FOR REFERENCE USE ONLY
- POTTED CONNECTORS SPECIFIED FOR UP TO 5 P.S.I. APPLICATIONS.

QUANTITY	PART NUMBER	DESCRIPTION	ITEM
	ATM13-12PX-BMXX	DTM13-12PA, DTM13-12PB, DTM13-12PC, DTM13-12PD, DTM13-12PA-G003, DTM13-12PB-G003, DTM13-12PC-G003, DTM13-12PD-G003	
<b>MATERIALS LIST</b>			
UNLESS OTHERWISE SPECIFIED 1) All dimensions are in metric (mm). 2) Tolerances are as follows: 1 PL DEC ±0.30   Fractions ±1/64 2 PL DEC ±0.15   Angles ±1° 3 PL DEC ±0.08 3) Note reference = △		SIGNATURES DRAWN: SULLEN,ZHANG 15JUN18 CHECKED: ORIONLI 15JUN18 ENGINEER: APPROVAL: TOMMY,XIE 15JUN18 CUSTOMER:	DATE
MATERIAL SPECIFICATIONS:		<b>Amphenol</b> Sine Systems - www.amphenol-sine.com 44724 Morley Drive Clinton Township, MI 48036	
PROCESS SPECIFICATIONS:		BOARDLOCK PCB MOUNT RECEPTACLE, 12 PIN, RA FLANGE, ATM SERIES	
NEXT ASSY:		THIS DRAWING IS SUPPLIED FOR INFORMATION ONLY. DESIGN FEATURES, SPECIFICATIONS AND PERFORMANCE DATA SHOWN HEREON ARE THE PROPERTY OF THE AMPHENOL CORPORATION. NO RIGHTS OF REPRODUCTION ARE IMPLIED. ALL DIMENSIONS ARE SUBJECT TO NORMAL MANUFACTURING VARIATIONS.	
		SIZE <b>B C-</b>	REVISION <b>A2</b>
		SCALE NONE	SHEET 1 OF 2

TITLE: PCB MOUNT RECEPTACLE, 12PIN, RA FLANGE, ATM SERIES

DWG NO:

ATM13-12PX-BMXX

REV: A2

SH: 1

OF: 2

REVISIONS					
REV	ECO	DESCRIPTION	DATE	BY	APPR
A1	-	RELEASE NEW DRAWING	15JUN18	SULLEN	TOMMY
A2	-	REVISED DRAWING	10JUL20	JHEAD	DH

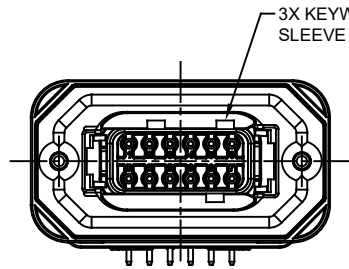

ATM13-12PA-BMXX  
KEY A

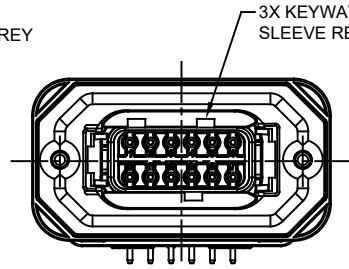

ATM13-12PB-BMXX  
KEY B

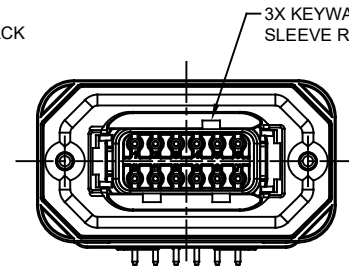

ATM13-12PC-BMXX  
KEY C

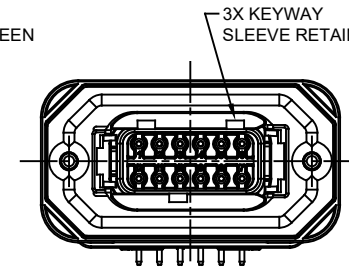

ATM13-12PD-BMXX  
KEY D

ATM13-12PA-BMXX VARIANTS		
CONTACT PLATING	POTTING OR NOT IN RESERVOIR	PART NUMBER
GOLD	NO POTTING	ATM13-12PA-BM01
GOLD	POTTING	ATM13-12PA-BM02
TIN	NO POTTING	ATM13-12PA-BM03
TIN	POTTING	ATM13-12PA-BM04

ATM13-12PB-BMXX VARIANTS		
CONTACT PLATING	POTTING OR NOT IN RESERVOIR	PART NUMBER
GOLD	NO POTTING	ATM13-12PB-BM01
GOLD	POTTING	ATM13-12PB-BM02
TIN	NO POTTING	ATM13-12PB-BM03
TIN	POTTING	ATM13-12PB-BM04

ATM13-12PC-BMXX VARIANTS		
CONTACT PLATING	POTTING OR NOT IN RESERVOIR	PART NUMBER
GOLD	NO POTTING	ATM13-12PC-BM01
GOLD	POTTING	ATM13-12PC-BM02
TIN	NO POTTING	ATM13-12PC-BM03
TIN	POTTING	ATM13-12PC-BM04

ATM13-12PD-BMXX VARIANTS		
CONTACT PLATING	POTTING OR NOT IN RESERVOIR	PART NUMBER
GOLD	NO POTTING	ATM13-12PD-BM01
GOLD	POTTING	ATM13-12PD-BM02
TIN	NO POTTING	ATM13-12PD-BM03
TIN	POTTING	ATM13-12PD-BM04

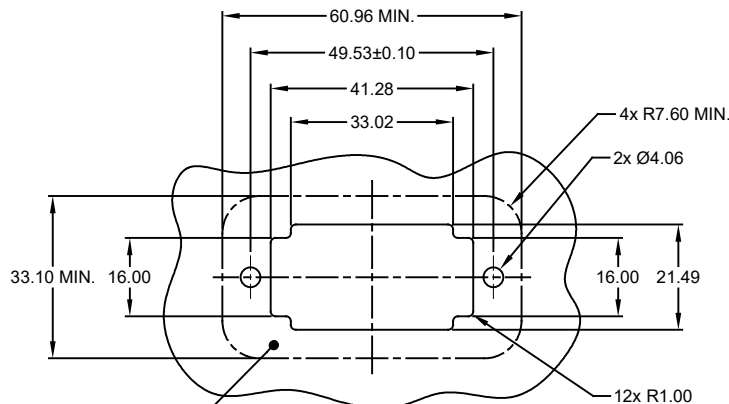

INTERNAL SEALING SURFACE  
FINISH TO BE  $\sqrt{3.2}$  OR BETTER

RECOMMENDED PANEL  
CUTOUT

ATM13-12PX-BMXX		DESCRIPTION		ITEM
PART NUMBER				
<b>QUANTITY</b>				
<b>MATERIALS LIST</b>				
UNLESS OTHERWISE SPECIFIED: 1) All dimensions are in metric(mm). 2) Tolerances are as follows: 1 PL DEC ±0.30 Fractions ±1/64 2 PL DEC ±0.15 Angles ±1° 3 PL DEC ±0.08				
SIGNATURES		DATE		
DRAWN: SULLEN,ZHANG		15JUN18		
CHECKED: ORION,LI		15JUN18		
ENGINEER:				
APPROVAL: TOMMY,XIE		15JUN18		
MATERIAL SPECIFICATIONS:		CUSTOMER:		
PROCESS SPECIFICATIONS:		THIS DRAWING IS SUPPLIED FOR INFORMATION ONLY. DESIGN FEATURES, SPECIFICATIONS AND PERFORMANCE DATA SHOWN HEREON ARE THE PROPERTY OF THE AMPHENOL CORPORATION. NO RIGHTS OF REPRODUCTION ARE IMPLIED. ALL DIMENSIONS ARE SUBJECT TO NORMAL MANUFACTURING VARIATIONS.		
NEXT ASSY:		SCALE: NONE		
		SIZE: B	TYPE: C-	DWG NO: ATM13-12PX-BMXX
				REVISION: A2
		SHEET 2 OF 2		

TITLE: PCB MOUNT RECEPTACLE, 12PIN, RA FLANGE, ATM SERIES  
DWG NO: ATM13-12PX-BMXX  
REV: A2  
SH: 2  
OF: 2