

PWM Step-Up DC/DC Controller for White-LED Driver

General Description

The RT9288A is a wide input operating voltage range step-up controller. High voltage output and large output current are feasible by using an external N-MOSFET. The RT9288A input operating range is from 3V to 13.5V. Besides, it could support up to 60V output at 12V input.

The RT9288A is an optimized design for WLED driver applications. Adjusting the output current of the RT9288A changes the brightness of the WLEDs. Chip Enable pin can be used as a digital input allowing WLED brightness control with a logic-level PWM signal.

Ordering Information

RT9288A□□

- Package Type
E : SOT-23-6
- Lead Plating System
P : Pb Free
G : Green (Halogen Free and Pb Free)

Note :

Richtek products are :

- ▶ RoHS compliant and compatible with the current requirements of IPC/JEDEC J-STD-020.
- ▶ Suitable for use in SnPb or Pb-free soldering processes.

Marking Information

For marking information, contact our sales representative directly or through a Richtek distributor located in your area.

Functional Pin Description

Pin No.	Pin Name	Pin Function
1	VDD	Supply Input Voltage Pin. Bypass an 1uF capacitor to GND to reduce the input noise.
2	EN	Chip Enable (Active High).
3	FB	Feedback to Error Amplifier Input.
4	COMP	Output of Error Amplifier. Connect a capacitor between the COMP pin and GND for compensation. While shutdown, this pin is pulled down by an internal resistor.
5	GND	Ground Pin.
6	EXT	Output for External Transistor.

Features

- **V_{IN} Operating Range : 3V to 13.5V**
- **Fixed PWM Frequency : 1MHz**
- **200Hz to 200kHz PWM Dimming Frequency**
- **Flexible PWM/Analog Dimming Control**
- **Voltage Mode with External Compensation**
- **Soft Start Function**
- **RoHS Compliant and 100% Lead (Pb)-Free**

Applications

- TFT LCD Panels
- LED Backlighting

Pin Configurations

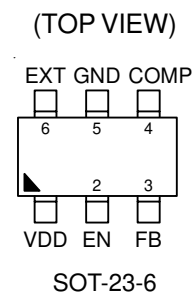

Typical Application Circuit

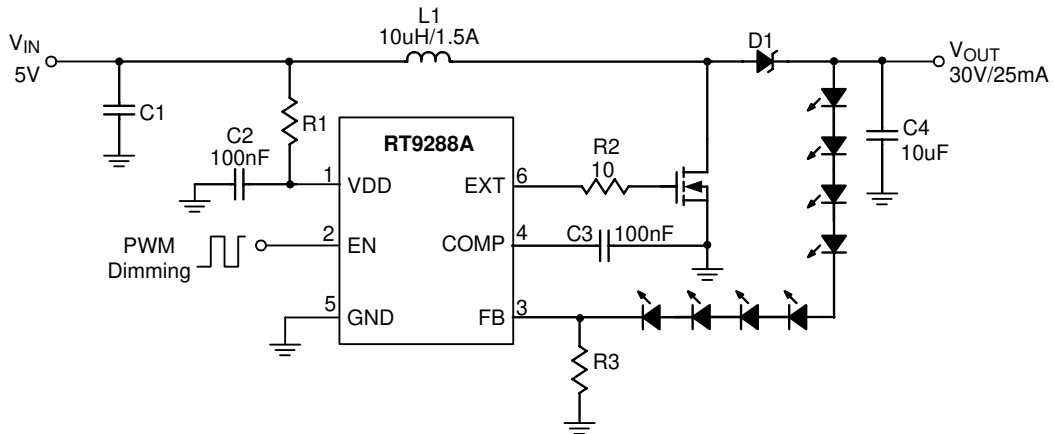

Figure 1. LED Driver with PWM Brightness Control (5V → 30V)

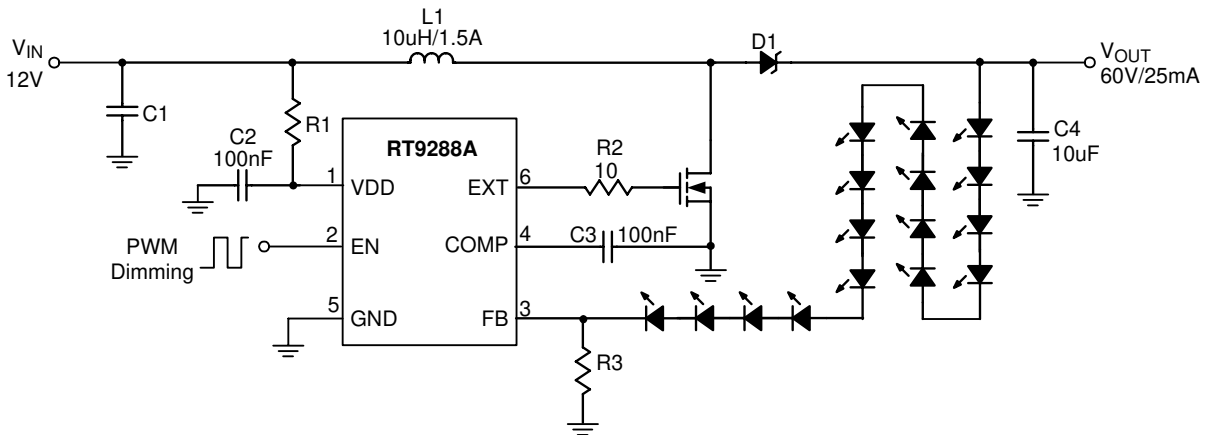

Figure 2. LED Driver with PWM Brightness Control (12V → 60V)

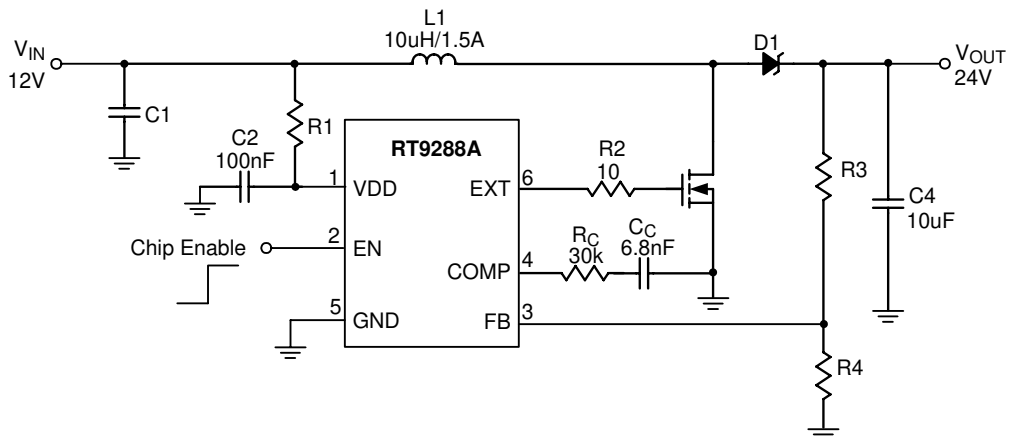
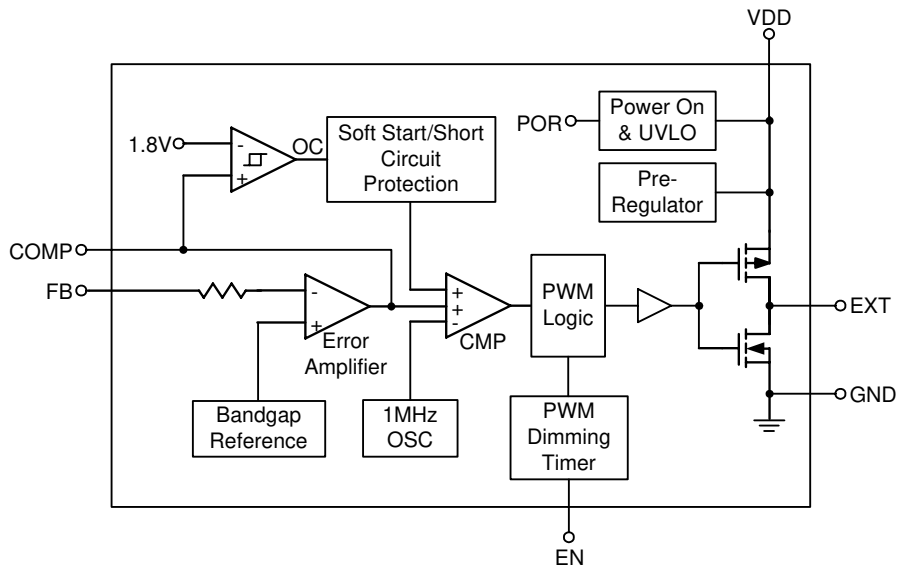

Figure 3. Application for Constant Output Voltage

Function Block Diagram



Operation

Soft-Start and Short Circuit Protection

While power-on, the RT9288A enters soft-start cycle to reduce the in-rush current and output voltage overshoot. The internal soft-start time is 10ms for the RT9288A. The RT9288A enters shutdown and can be re-enabled by turning off-on EN pin.

In normal operation, if the output loading changes large enough to let error amplifier output larger than 1.8V, the short circuit timer is started. If the time duration of this condition is kept continuously to more than 10ms, the short circuit state is latched and the RT9288 enters shutdown and can be re-enabled by turning off-on EN pin.

Dimming Control for LED Lighting

EN is also used as a digital input allowing LED brightness control with a logic-level PWM signal applied directly to EN. The frequency range is from 200Hz to 200kHz, while 0% duty cycle corresponds to zero current and 100% duty cycle corresponds to full current. The error amplifier and compensation capacitor form a lowpass filter, so the PWM dimming results in DC current to the LEDs without any additional RC filters. The PWM signal must be applied after soft-start finished.

Under-Voltage Lock-out

The under voltage lock-out circuit is adopted as a voltage detector and always monitors the supply voltage (V_{DD}) while EN at logic High. While power-on, the chip is kept in shutdown mode till the V_{DD} rises to higher than 2.5V (MAX). While power-off, the chip does not leave operating mode till V_{DD} falls to less than 2.2V(MIN).

Absolute Maximum Ratings (Note 1)

- Supply Input Voltage, V_{DD} ----- -0.3V to 16V
- EN, EXT Pins ----- -0.3V to $V_{DD} + 0.3V$
- FB, COMP Pins ----- -0.3V to 7V
- Power Dissipation, $P_D @ T_A = 25^\circ C$
- SOT-23-6 ----- 0.455W
- Package Thermal Resistance (Note 2)
- SOT-23-6, θ_{JA} ----- 220°C/W
- Lead Temperature (Soldering, 10 sec.) ----- 260°C
- Junction Temperature ----- 150°C
- Storage Temperature Range ----- -65°C to 150°C
- ESD Susceptibility (Note 3)
- HBM (Human Body Mode) ----- 2kV
- MM (Machine Mode) ----- 200V

Recommended Operating Conditions (Note 4)

- Supply Input Voltage, V_{DD} ----- 3V to 13.5V
- Junction Temperature Range ----- -40°C to 125°C
- Ambient Temperature Range ----- -40°C to 85°C

Electrical Characteristics

($V_{DD} = 5V$, $T_A = 25^\circ C$, unless otherwise specified)

Parameter	Symbol	Test Conditions	Min	Typ	Max	Unit
Power-On Reset						
Operating Supply Voltage Range	V_{DD}	Normal operation	3	5	13.5	V
Under Voltage Lock Out	UVLO	V_{DD} Rising	2.2	--	2.5	V
Supply current in PWM Mode	I_{PWM}	$V_{FB} = V_{REF} + 0.1V$	--	2	--	mA
Shutdown Current	I_{SHDN}	$V_{EN} = 0V$	--	1	10	uA
Sawtooth Generator						
Oscillation Frequency	f_{OSC}		0.8	1	1.2	MHz
Frequency Stability		$V_{DD} = 3V$ to 13.5V	--	2	10	%
Maximum Duty Cycle			85	90	95	%
Error Amplifier						
Trans-Conductance	GM		--	60	--	uA/V
Feedback Voltage	V_{FB}		--	0.5	--	V
Feedback Line Regulation		$V_{DD} = 3V$ to 13.5V	--	5	--	mV
Maximum Output Voltage	V_{FB_MAX}	$V_{COMP} = V_{FB} = low$	--	2.4	--	V
Minimum Output Voltage	V_{FB_MIN}	$V_{COMP} = V_{FB} = high$	--	0.05	--	V
Output Source Current		$V_{COMP} = 0.7V$, $V_{FB} = low$	--	20	--	uA
Output Sink Current		$V_{COMP} = 0.7V$, $V_{FB} = high$	--	20	--	uA
Soft Start & Short Circuit Unit						
Soft-Start Ramp Time			5	10	20	ms

To be continued

Parameter	Symbol	Test Conditions	Min	Typ	Max	Unit
Output driver						
On Resistance (P-MOSFET)	$R_{DS(ON) P}$		--	30	60	Ω
On Resistance (N-MOSFET)	$R_{DS(ON) N}$		--	20	40	Ω
Output rising/falling time (Note 5)		$C_L = 1000\text{pF}, V_{FB} = \text{Low}$	--	100	--	ns
Logic						
EN Pin Low Voltage	V_{IL}		--	--	0.5	V
EN Pin High Voltage	V_{IH}		1.8	--	V_{DD}	V

Note 1. Stresses listed as the above “Absolute Maximum Ratings” may cause permanent damage to the device. These are for stress ratings. Functional operation of the device at these or any other conditions beyond those indicated in the operational sections of the specifications is not implied. Exposure to absolute maximum rating conditions for extended periods may remain possibility to affect device reliability.

Note 2. θ_{JA} is measured in the natural convection at $T_A = 25^\circ\text{C}$ on a low effective thermal conductivity test board of JEDEC 51-3 thermal measurement standard.

Note 3. Devices are ESD sensitive. Handling precaution is recommended.

Note 4. The device is not guaranteed to function outside its operating conditions.

Note 5. Guarantee by design.

Typical Operating Characteristics

Efficiency vs. Output Current

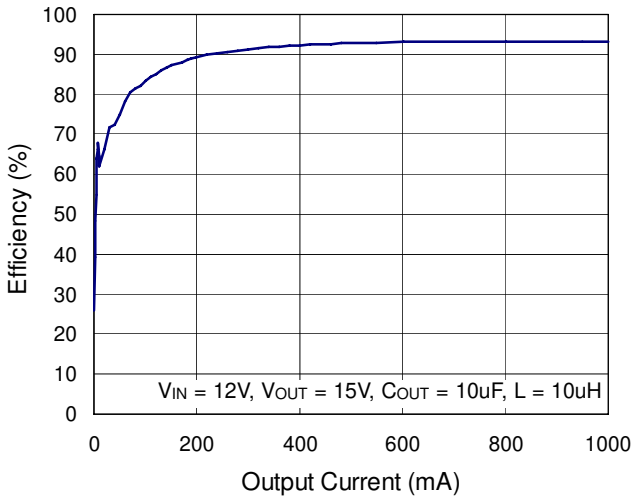

Efficiency vs. Output Current

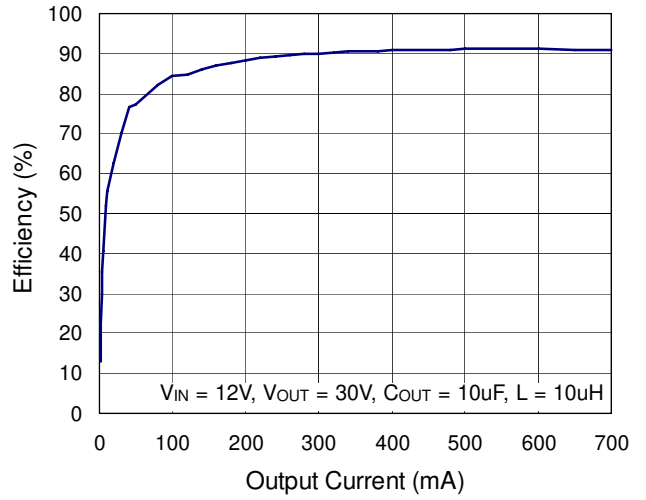

Output Voltage vs. Output Current

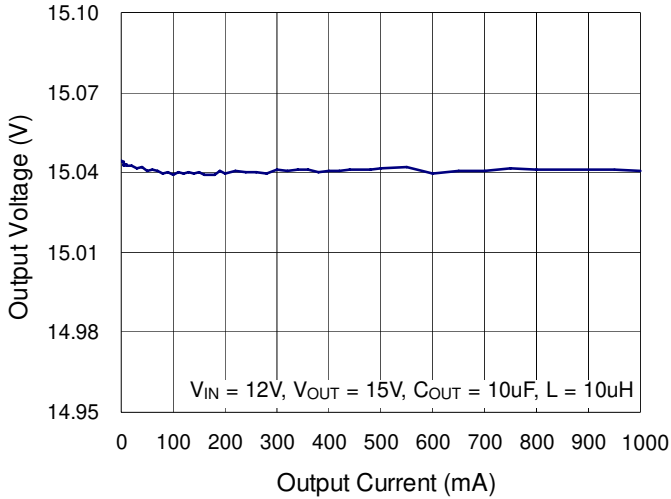

Output Voltage vs. Output Current

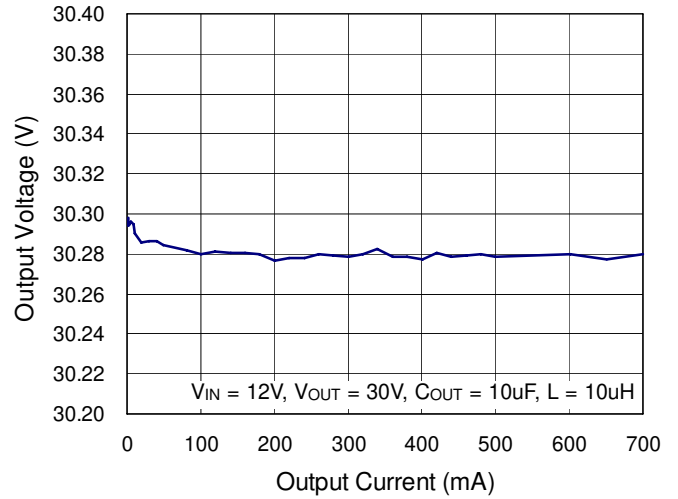

Output Voltage vs. Input Voltage

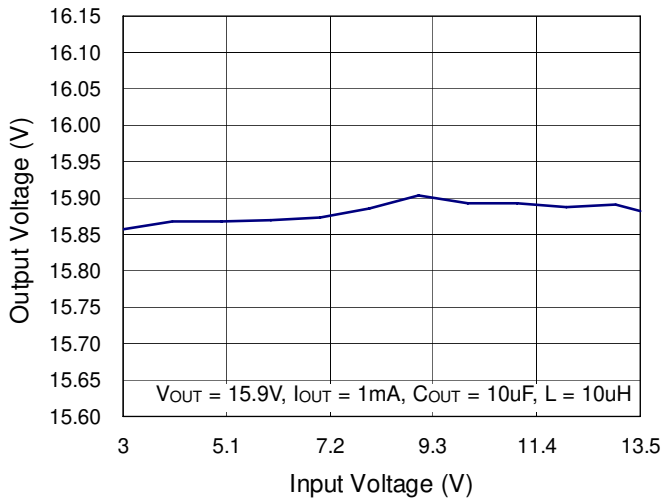

Supply Current vs. Input Voltage

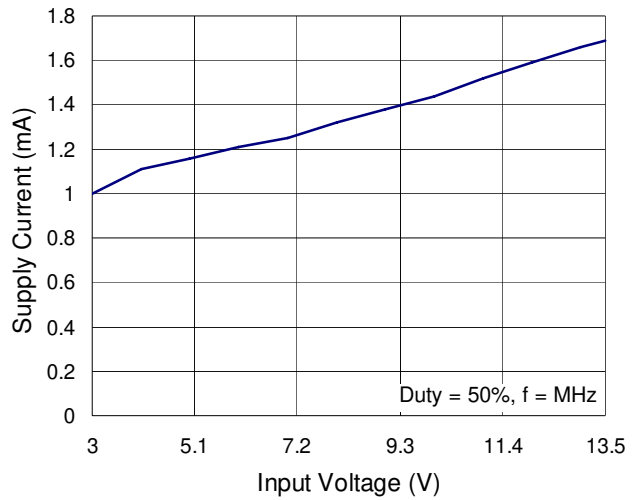

Supply Current vs. Temperature

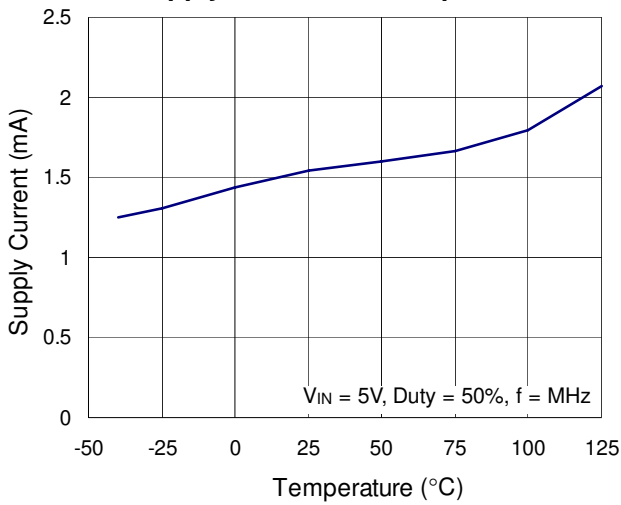

Frequency vs. Input Voltage

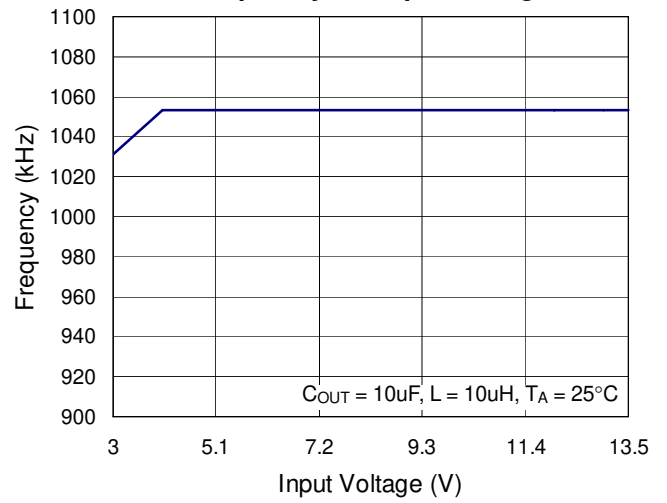

Frequency vs. Temperature

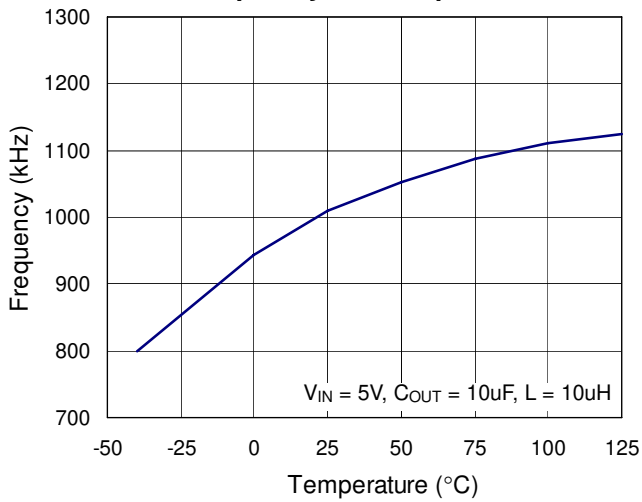

Maximum Duty vs. Temperature

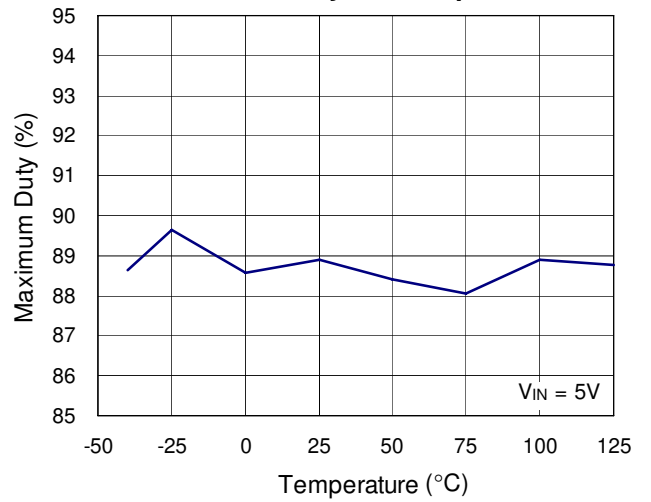

VFB vs. Temperature

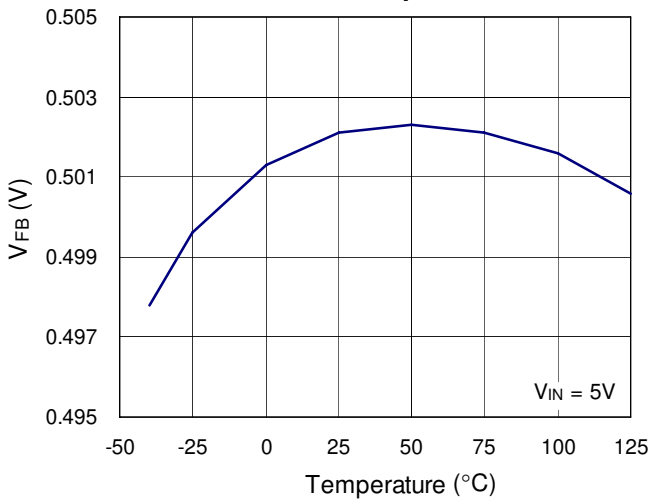

VFB vs. Input Voltage

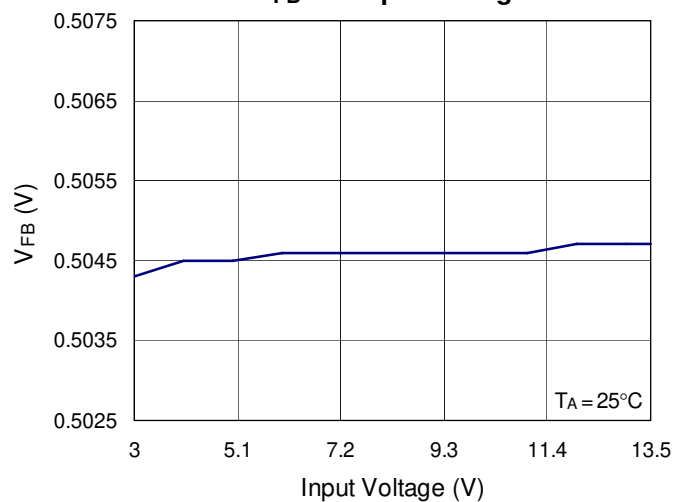

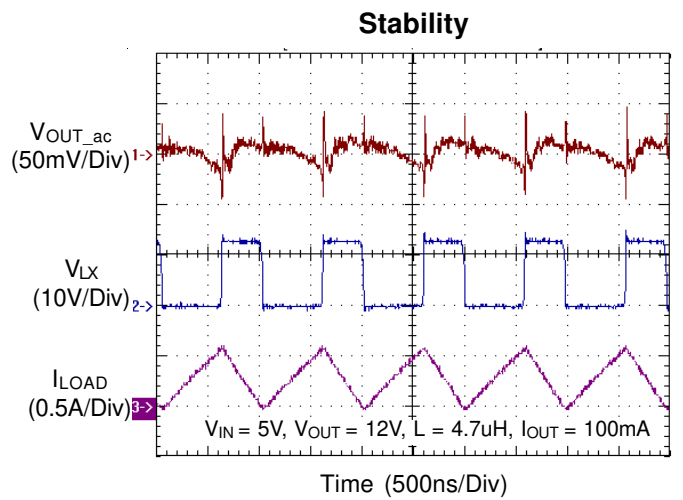
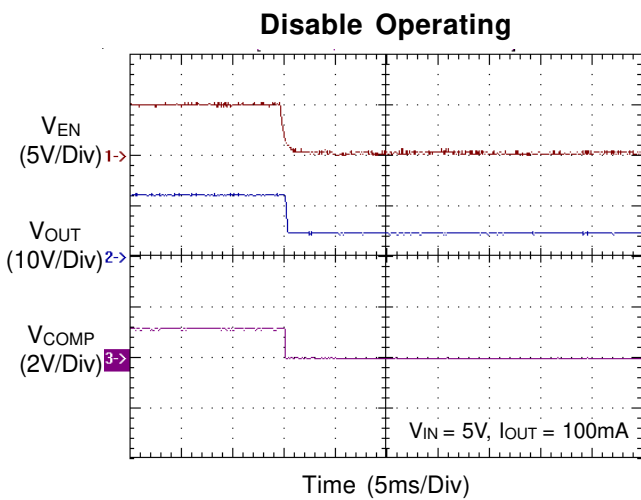
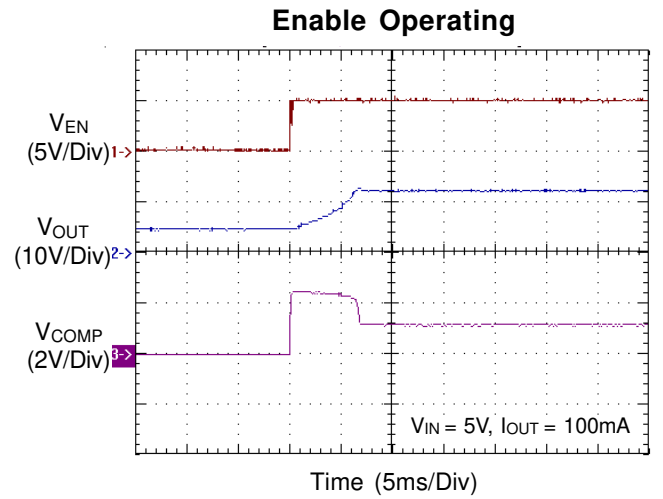
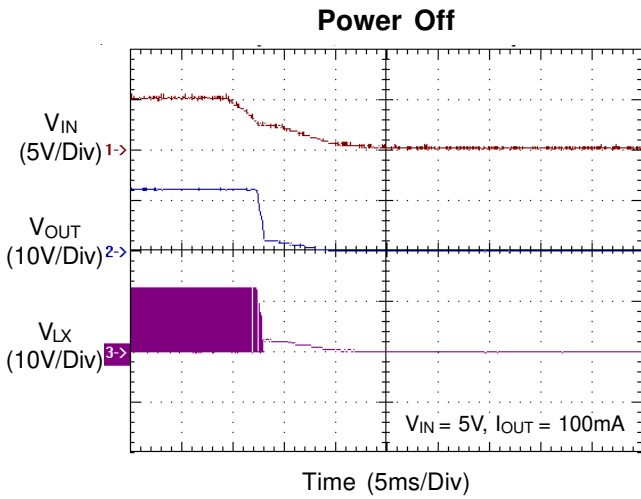
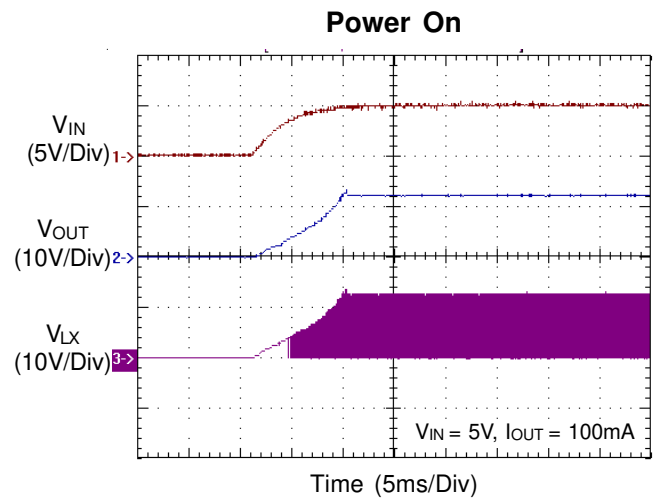
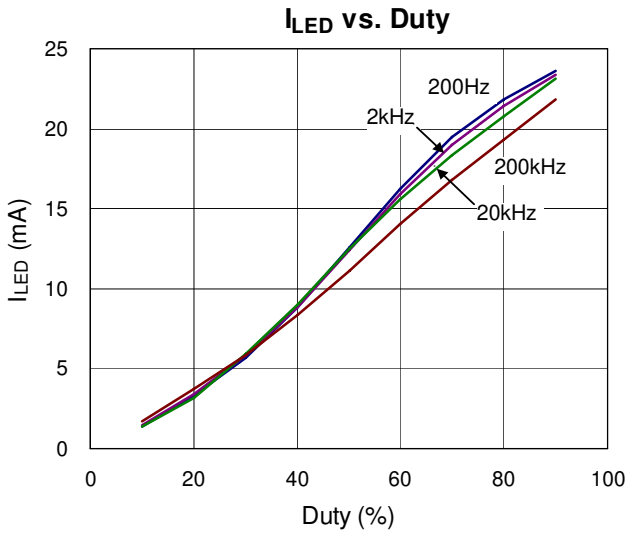

Stability

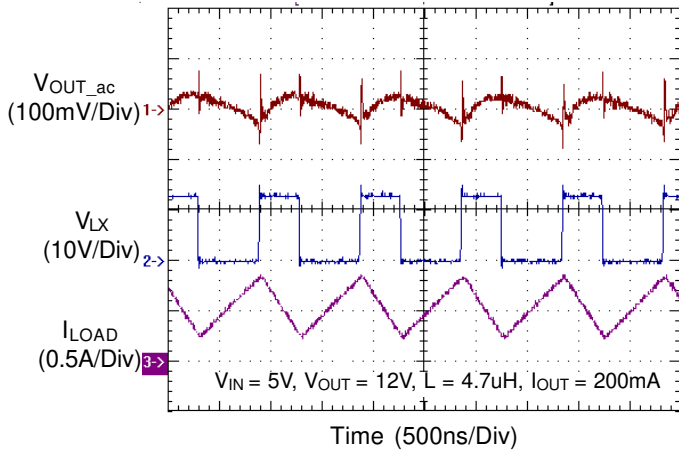

Stability

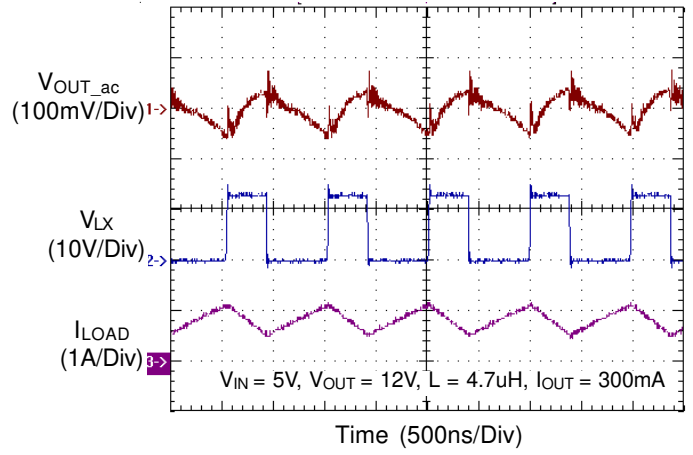

PWM Dimming by EN

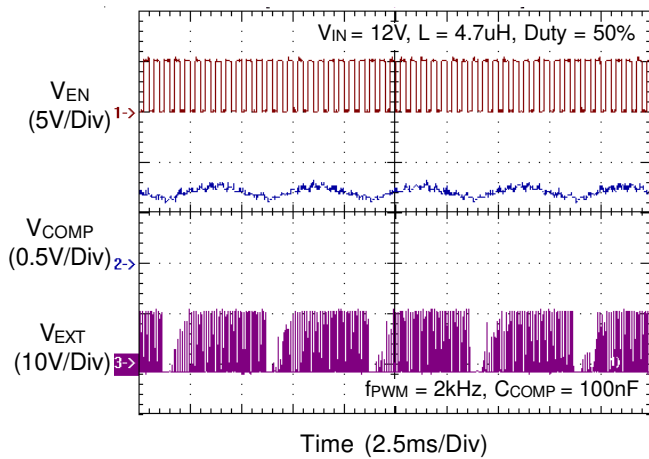

Application Information

The RT9288A is a boost controller for DC to DC conversion. The main switch of the power stage can stand significant current that is greater than the internal main switch. There is no significant power dissipated in the RT9288A, therefore the thermal performance could be excellent. For the RT9288A, determine the maximum input current is the first step of the design procedure.

Inductor Selection

For the inductor selection, the inductance value depends on the maximum input current. Generally the inductor ripple current range is 20% to 40% of the maximum input current. Take 40% as an example, the value can be calculated as follows :

$$I_{IN(MAX)} = \frac{V_{OUT} \times I_{OUT(MAX)}}{\eta \times V_{IN}} \quad (1)$$

$$I_{RIPPLE} = 0.4 \times I_{IN(MAX)} \quad (2)$$

Where η is the efficiency, $I_{IN(MAX)}$ is the maximum input current and I_{RIPPLE} is the inductor ripple current. Beside, the input peak current is the maximum input current plus half of the inductor ripple current.

$$I_{PEAK} = 1.2 \times I_{IN(MAX)} \quad (3)$$

Note that the saturated current of inductor must be greater than I_{PEAK} . The inductance value can be eventually determined as follows :

$$L = \frac{\eta \times (V_{IN})^2 \times (V_{OUT} - V_{IN})}{0.4 \times (V_{OUT})^2 \times I_{OUT(MAX)} \times f_{OSC}} \quad (4)$$

Where f_{OSC} is the switching frequency. Consider the system performance, a shielded inductor is preferred to avoid EMI issue.

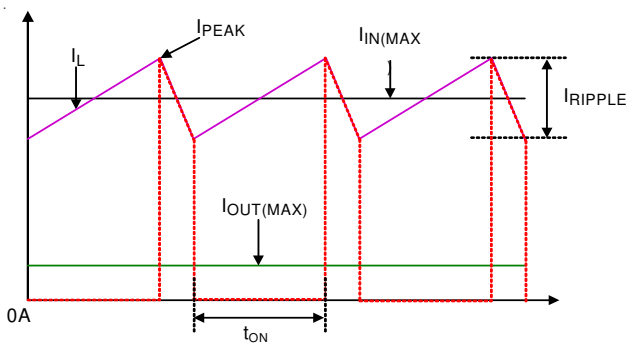

Figure 4. The Waveform of the Inductor Current

Diode Selection

Schottky diode is a good choice for an asynchronous Boost converter due to the small forward voltage. However, power dissipation, reverse voltage rating and pulsating peak current are the important parameters of Schottky diode consideration. It is recommended to choose a suitable diode whose reverse voltage rating is greater than the maximum output voltage.

Input Capacitor Selection

Low ESR ceramic capacitors are recommended for input capacitor applications. Low ESR will effectively reduce the input ripple voltage caused by switching operation. A 10uF is sufficient for most applications. Nevertheless, this value can be decreased with lower output current requirement. Another consideration is the voltage rating of input capacitor must be greater than the maximum input voltage.

Output Capacitor Selection

Output ripple voltage is an important index for estimating the performance. This portion consists of two parts, one is the product of $(I_{IN} - I_{OUT})$ and ESR of the output capacitor, another part is formed by charging and discharging process of output capacitor. Refer to figure 5, evaluate ΔV_{OUT1} by ideal energy equalization. According to the definition of Q that is calculated as follows :

$$Q = \frac{1}{2} \times \left[\left(I_{IN} + \frac{1}{2} \Delta I_L - I_{OUT} \right) + \left(I_{IN} - \frac{1}{2} \Delta I_L - I_{OUT} \right) \right] \quad (5)$$

$$\times \frac{V_{IN}}{V_{OUT}} \times \frac{1}{f_{OSC}} = C_{OUT} \times \Delta V_{OUT1}$$

Where T_S is the inverse of switching frequency and the ΔI_L is the inductor ripple current. Move C_{OUT} to left side to estimate the value of ΔV_{OUT1} as :

$$\Delta V_{OUT1} = \frac{D \times I_{OUT}}{\eta \times C_{OUT} \times f_{OSC}} \quad (6)$$

Finally, the output ripple voltage can be determined as :

$$\Delta V_{OUT} = (I_{IN} - I_{OUT}) \times ESR + \frac{D \times I_{OUT}}{\eta \times C_{OUT} \times f_{OSC}} \quad (7)$$

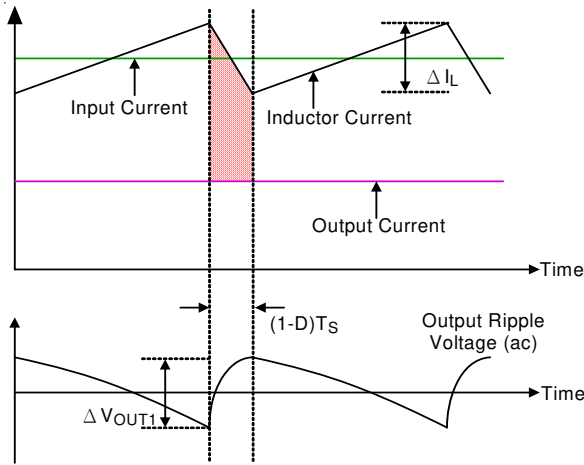

Figure 5. The Output Ripple Voltage without the Contribution of ESR

Main Switch Selection

The RT9288A uses an N-MOSFET as the main switch to achieve power conversion. The main switch stays in two states in the operation, one is the on state and the other is the off state. The potential of switching point, LX, is 0V in the on state. Nevertheless, the potential of LX rises to output voltage plus the forward voltage of D_1 in the off state, this potential is the highest voltage in the Boost converter. Thus, the absolute V_{DS} rating of the main switch must be greater than this voltage to prevent main switch damage in the off state or reliability problem. Another key parameter of main switch is the maximum continuous drain current. For a safety design, it is important to choose a maximum continuous drain current at two times the maximum input current. Energy saving is the trend in recent years. Therefore, design a high efficiency system is the important course. Conduction loss and switching loss play important roles for the efficiency in heavy load and light load respectively. Main switch with a small on resistance leads to lower conduction loss, however, it also means a greater gate capacitance. Great gate capacitance prolongs rising and falling transition in LX, t_1 and t_2 . I_L and V_{LX} produce the main switching loss during t_1 and t_2 . Thus, choose a main switch with proper gate capacitance could reduce switching loss.

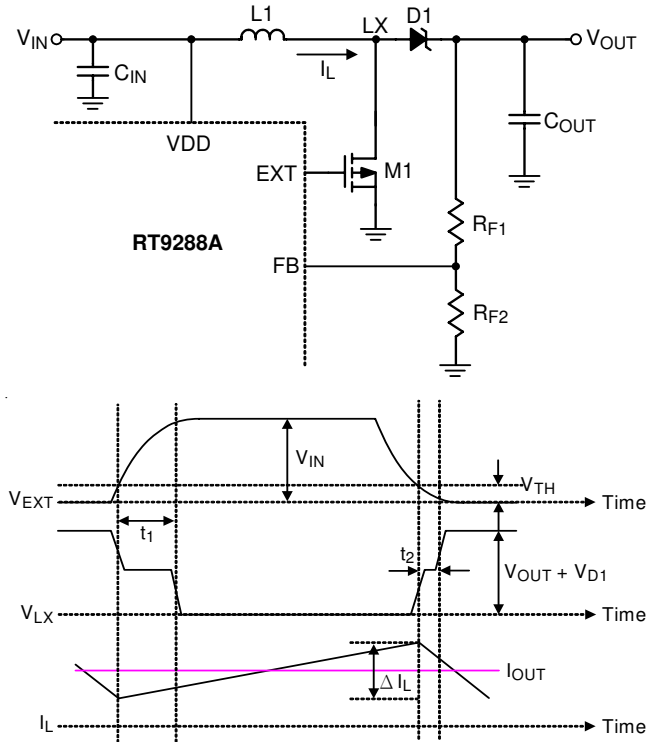

Figure 6. The Waveforms of EXT, LX and Inductor Current Related to the Switching Loss

Loop Compensation

It is easy to compensate the loop stability for the RT9288A's application in LED driving. Compensation network only contains a capacitor between COMP pin and GND as shown in figure 1. The best criterion to optimize the loop compensation is by inspecting the transient response and adjusting the compensation network.

Layout Consideration

The PCB layout is a very important issue for switching converter circuits design. There are some recommended layout guidelines that are shown as follows :

- ▶ The power components M1, L1, D1, C_{IN} and C_{OUT} should be placed as close to the IC as possible to reduce the ac current loop. The connections between power components must be short and wide as possible due to large current stream flowing through these traces during operation.
- ▶ The function of C1 is to regulate V_{DD} . Place C1 close to pin 1 is necessary.

- ▶ R_{F1} and R_{F2} formed a voltage divider to set correct output voltage. Pin 3 is connected to the branch of voltage divider and is a very sensitive point, placed this trace short and wide as possible and far away from the switching point to avoid perturbation.
- ▶ Pin 4 is the compensation point for system stability. Place the compensation components as close to pin 4 as possible, no matter the compensation is R_C or capacitance. Note that, the GND of the compensation components should be connected with pin 5. Then, short it to system ground by via or trace. This will provide a clean reference for the IC.

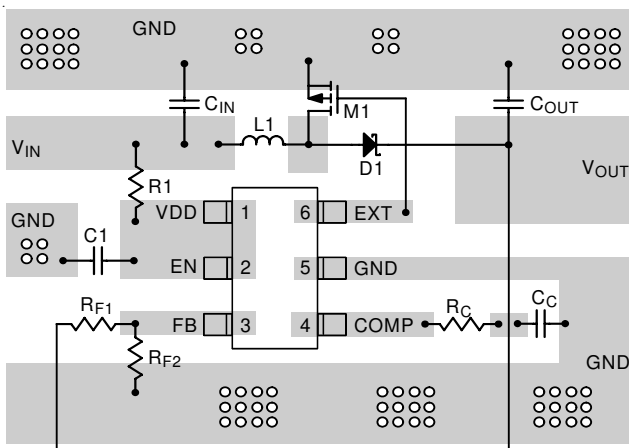
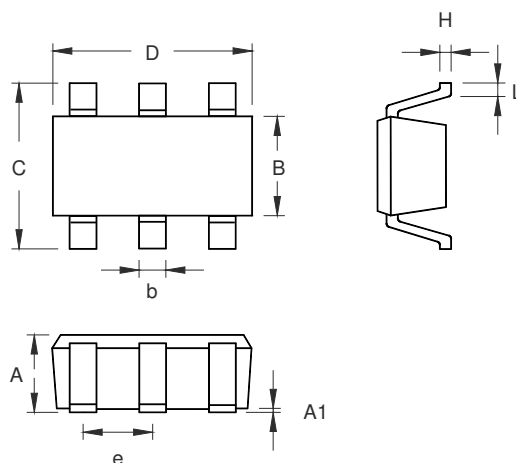

Figure 7. Sketch Map of PCB Layout.

Outline Dimension



Symbol	Dimensions In Millimeters		Dimensions In Inches	
	Min	Max	Min	Max
A	0.889	1.295	0.031	0.051
A1	0.000	0.152	0.000	0.006
B	1.397	1.803	0.055	0.071
b	0.250	0.560	0.010	0.022
C	2.591	2.997	0.102	0.118
D	2.692	3.099	0.106	0.122
e	0.838	1.041	0.033	0.041
H	0.080	0.254	0.003	0.010
L	0.300	0.610	0.012	0.024

SOT-23-6 Surface Mount Package

Richtek Technology Corporation

Headquarter
 5F, No. 20, Taiyuen Street, Chupei City
 Hsinchu, Taiwan, R.O.C.
 Tel: (8863)5526789 Fax: (8863)5526611

Richtek Technology Corporation

Taipei Office (Marketing)
 5F, No. 95, Minchiuan Road, Hsintien City
 Taipei County, Taiwan, R.O.C.
 Tel: (8862)86672399 Fax: (8862)86672377
 Email: marketing@richtek.com

Information that is provided by Richtek Technology Corporation is believed to be accurate and reliable. Richtek reserves the right to make any change in circuit design, specification or other related things if necessary without notice at any time. No third party intellectual property infringement of the applications should be guaranteed by users when integrating Richtek products into any application. No legal responsibility for any said applications is assumed by Richtek.