

PROJECT NAME

DEMENSION IN METRIC

DO NOT SCALE DRAWING

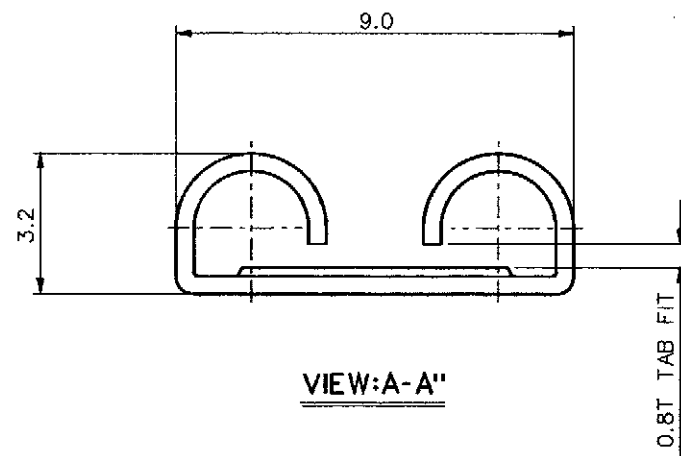
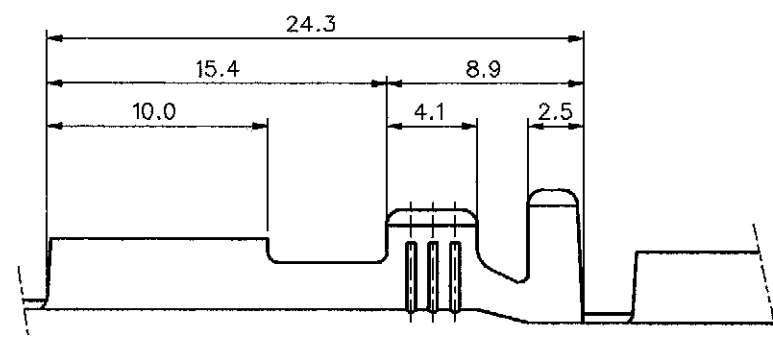
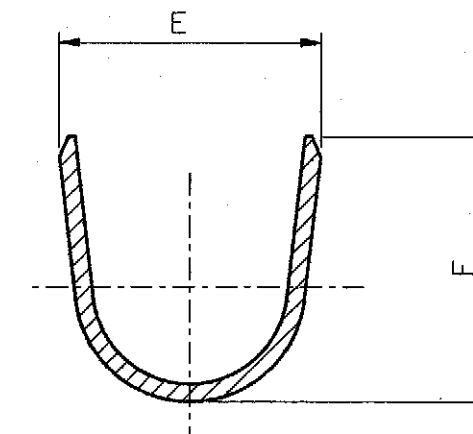
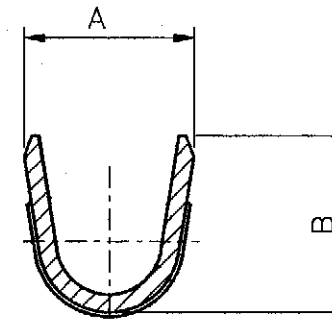
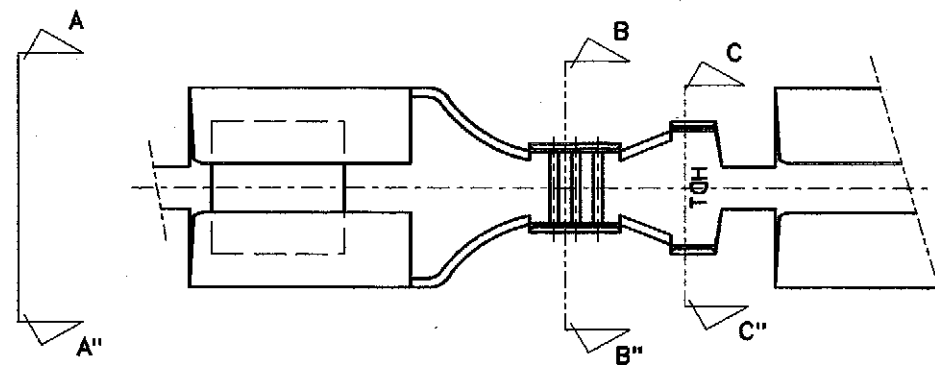

SECTION: B-B''

SECTION: C-C''

PART.NO	A	B	E	F
35032-980*	3.6	3.7	5.3	5.1
35032-990*	4.9	6.2	8.5	8.5

NOTES

- MATERIAL: BRASS, THK': 0.4
- PLATING: POST-TIN PLATING
- WIRE SIZE: AWG#14-12: **35032-980*** * : 0.4_L plated
AWG#12-10: **35032-990***

					PACKAGING 2,000 Q'TY / REEL	TOLERANCES IN METRIC		IMPORTANCE CLASSIFICATION		MATERIAL		SHEET NO. 10F1	DATE 1992.3.12
					WIRE RANGE	3 PLACE ± 2 PLACE ± 1 PLACE ±0.30 METRIC (INCH)		▽: CRITICAL ▼: MAJOR □: MINOR (): REFERENCE		CODE :SEE NOTES THK. : ± WIDTH : ±		REVISE ONLY ON CAD SYSTEM	
B	Revised	92-012	YANG	92.9.29	AWG.: SEE	TOLERANCES ANGULAR : 0.5°		DRAWN BY W.Y.YANG		CHK'D BY		TITLE: .312 SLIP-ON RECEPTACLE	
A	NEW RELEASE		YANG	1992.3.12	MM ² : TABLE			APP'D BY		SCALE N/S		EDP.NO.	ENG.NO. SD 35032-9***
LTR	REVISION RECORD	ECN NO.	NAME	DATE									REV.

8

7

6

5

4

3

2

MOLEX KOREA CO.,LTD