

April 1995

8A, 1200V Ultrafast Diode

Features

- Ultrafast with Soft Recovery <100ns
- Operating Temperature +175°C
- Reverse Voltage 1200V
- Avalanche Energy Rated
- Planar Construction s

Applications

- Switching Power Supplies
- Power Switching Circuits
- General Purpose

Description

The RURP8120 (TA49095) are ultrafast diodes with soft recovery characteristics ($t_{RR} < 100ns$). They have low forward voltage drop and are silicon nitride passivated ion-implanted epitaxial planar construction.

These devices are intended for use as freewheeling/clamping diodes and rectifiers in a variety of switching power supplies and other power switching applications. Their low stored charge and ultrafast soft recovery minimize ringing and electrical noise in many power switching circuits reducing power loss in the switching transistors.

PACKAGING AVAILABILITY

PART NUMBER	PACKAGE	BRAND
RURP8120	TO-220AC	RURP8120

NOTE: When ordering, use the entire part number.

Package

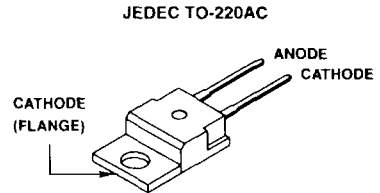

Symbol



Absolute Maximum Ratings $T_C = +25^\circ C$, Unless Otherwise Specified

	RURP8120	UNITS
Peak Repetitive Reverse Voltage V_{RRM}	1200	V
Working Peak Reverse Voltage V_{RWM}	1200	V
DC Blocking Voltage V_R	1200	V
Average Rectified Forward Current $I_{F(AV)}$ ($T_C = +144^\circ C$)	8	A
Repetitive Peak Surge Current I_{FSM} (Square Wave, 20kHz)	16	A
Nonrepetitive Peak Surge Current I_{FSM} (Halfwave, 1 Phase, 60Hz)	100	A
Maximum Power Dissipation P_D	75	W
Avalanche Energy (See Figure 10 and Figure 11) E_{AVL}	20	mJ
Operating and Storage Temperature T_{STG}, T_J	-65 to +175	$^\circ C$

Specifications RURP8120

Electrical Specifications $T_C = +25^\circ\text{C}$, Unless Otherwise Specified

SYMBOL	TEST CONDITION	MIN	TYP	MAX	UNITS
V_F	$I_F = 8\text{A}$, $T_C = +25^\circ\text{C}$	-	-	2.1	V
	$I_F = 8\text{A}$, $T_C = +150^\circ\text{C}$	-	-	1.9	V
I_R	$V_R = 1200\text{V}$, $T_C = +25^\circ\text{C}$	-	-	100	μA
	$V_R = 1200\text{V}$, $T_C = +150^\circ\text{C}$	-	-	500	μA
t_{RR}	$I_F = 1\text{A}$, $dI_F/dt = 100\text{A}/\mu\text{s}$	-	-	100	ns
	$I_F = 8\text{A}$, $dI_F/dt = 100\text{A}/\mu\text{s}$	-	-	110	ns
t_A	$I_F = 8\text{A}$, $dI_F/dt = 100\text{A}/\mu\text{s}$	-	60	-	ns
t_B	$I_F = 8\text{A}$, $dI_F/dt = 100\text{A}/\mu\text{s}$	-	40	-	ns
Q_{RR}	$I_F = 8\text{A}$, $dI_F/dt = 100\text{A}/\mu\text{s}$	-	380	-	nC
C_J	$V_R = 10\text{V}$, $I_F = 0\text{A}$	-	25	-	pF
$R_{\theta JC}$		-	-	2	$^\circ\text{C}/\text{W}$

DEFINITIONS

V_F = Instantaneous forward voltage ($p_w = 300\mu\text{s}$, $D = 2\%$).

I_R = Instantaneous reverse current.

t_{RR} = Reverse recovery time (See Figure 2), summation of $t_A + t_B$.

t_A = Time to reach peak reverse current (See Figure 2)

t_B = Time from peak I_{RM} to projected zero crossing of I_{RM} based on a straight line from peak I_{RM} through 25% of I_{RM} (See Figure 2).

$R_{\theta JC}$ = Thermal resistance junction to case.

E_{AVL} = Controlled avalanche energy. (See Figures 10 and 11).

Q_{RR} = Reverse Recovery Charge.

C_J = Junction Capacitance.

p_w = pulse width.

D = duty cycle.

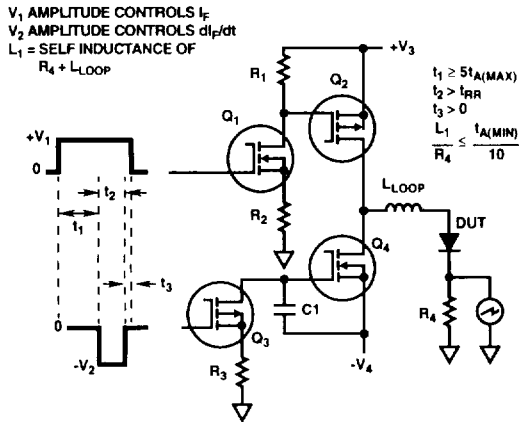

FIGURE 1. t_{RR} TEST CIRCUIT

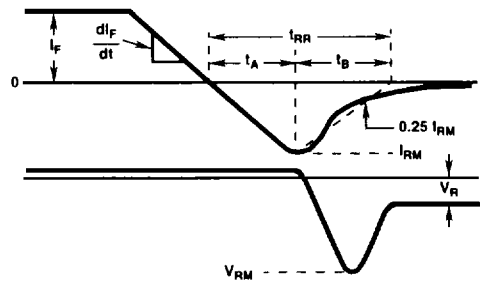

FIGURE 2. t_{RR} WAVEFORMS AND DEFINITIONS

Typical Performance Curves

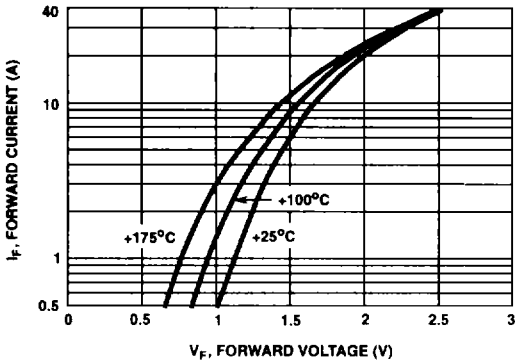

FIGURE 3. TYPICAL FORWARD CURRENT vs FORWARD VOLTAGE DROP

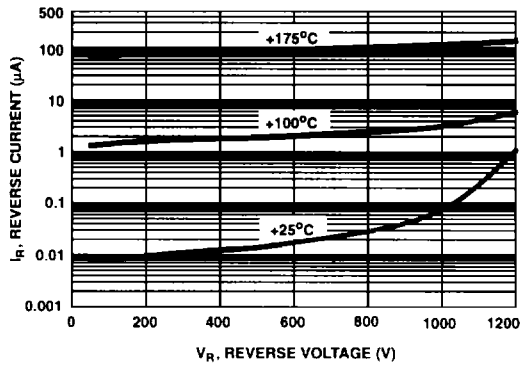

FIGURE 4. TYPICAL REVERSE CURRENT vs REVERSE VOLTAGE

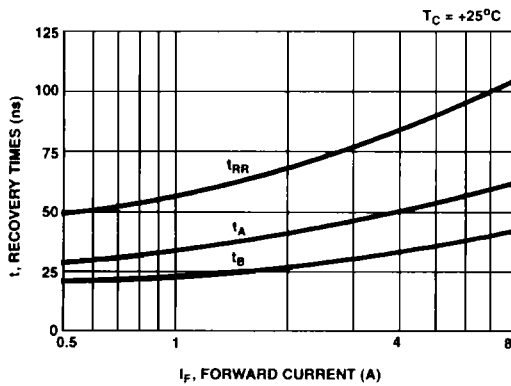

FIGURE 5. TYPICAL t_{RR} , t_A AND t_B CURVES vs FORWARD CURRENT AT +25°C

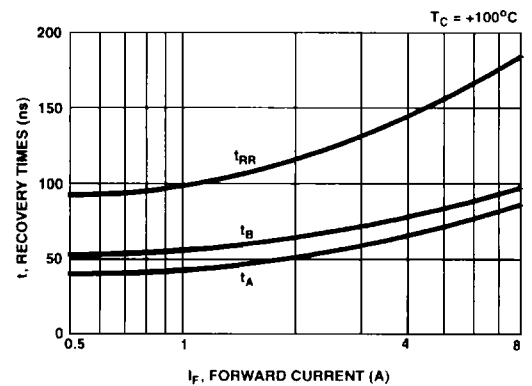

FIGURE 6. TYPICAL t_{RR} , t_A AND t_B CURVES vs FORWARD CURRENT AT +100°C

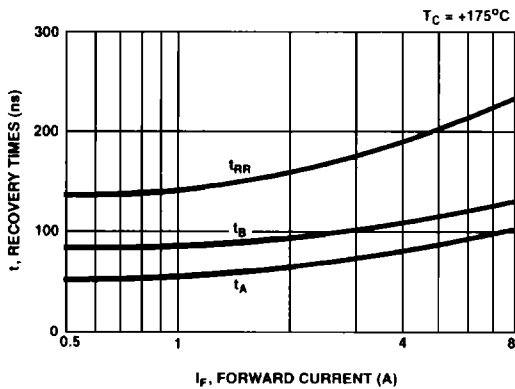

FIGURE 7. TYPICAL t_{RR} , t_A AND t_B CURVES vs FORWARD CURRENT AT +175°C

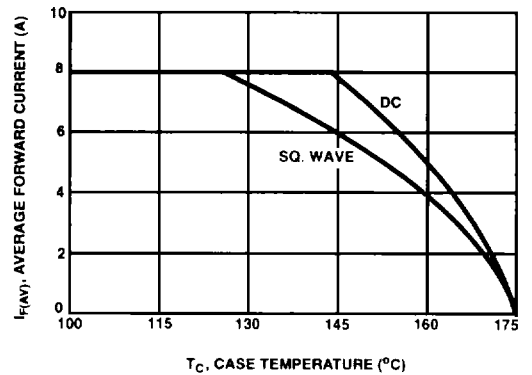

FIGURE 8. CURRENT DERATING CURVE FOR ALL TYPES

Typical Performance Curves (Continued)

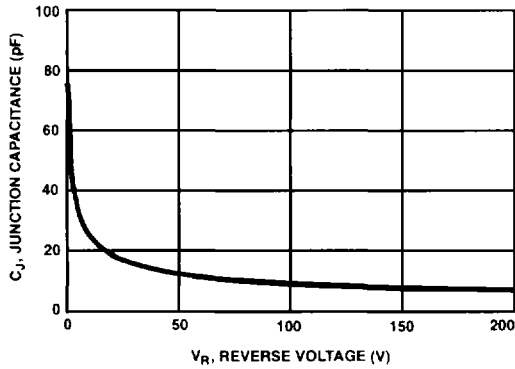

FIGURE 9. TYPICAL JUNCTION CAPACITANCE vs REVERSE VOLTAGE

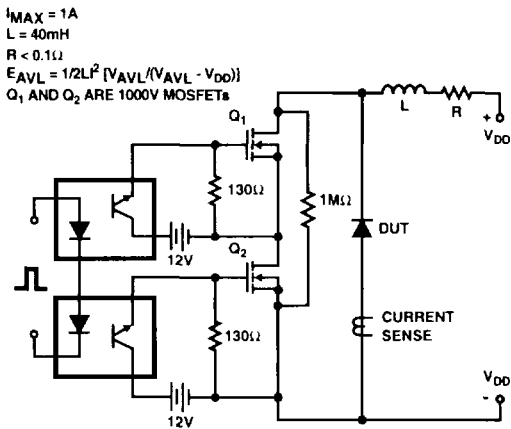

FIGURE 10. AVALANCHE ENERGY TEST CIRCUIT

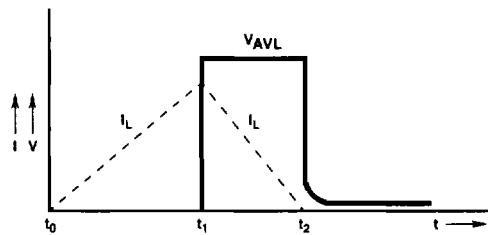

FIGURE 11. AVALANCHE CURRENT AND VOLTAGE WAVEFORMS