

10/100 BASE-TX Low Profile SMD LAN Transformer Module

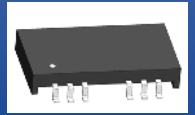

ALANL100X1



12.7 x 7.1 x 2.1 mm
 RoHS/RoHS II Compliant
 MSL = 1

Features

- Low Profile of 2.15 mm
- Meets IEEE 802.3u standards
- Compatible with 10 BASE-T and 100 BASE-TX
- RoHS Compliant
- High performance magnetics for EMI suppression and common mode noise rejection
- 1CT:1CT TX and RX Transformers

Applications

- Fast Ethernet
- IP cameras, surveillance, and IP phone
- Industrial computers and robotics
- PC Card and Cardbus

Part Identification

ALANL100X1 - [] [] [] []

Package Size
D: 12-Pin
E: 16-Pin

Schematic	
12-Pin	16-Pin
E10	F10
E12	F12
E62	F62
ED2	FD2

Operating Temp.
E: 0 °C to +70 °C
D: -40 °C to +85 °C
J: -40 °C to +105 °C
K: -40 °C to +125 °C

Packaging
B: Bulk
T: 2,000 pcs/reel

10/100 BASE-TX Low Profile SMD LAN Transformer Module



ALANL100X1



12.7 x 7.1 x 2.1 mm
RoHS/RoHS II Compliant
MSL = 1

Electrical Specifications at 25°C

Part Number	Insertion Loss (dB Max)	Return Loss (dB Min)				Crosstalk (dB Min)			CMRR (dB Min)			DCMR (dB Min)		
	0.5-100 MHz	1-40 MHz	60 MHz	80 MHz	100 MHz	30 MHz	60 MHz	100 MHz	30 MHz	60 MHz	100 MHz	30 MHz	60 MHz	100 MHz
ALANL100X1-DE10	1.2	18	14.4	12	10	45	40	35	43	37	33	43	37	33
ALANL100X1-DE12	1.2	18	14.4	12	10	45	40	35	43	37	33	43	37	33
ALANL100X1-DE62	1.2	18	14.4	12	10	45	40	35	43	37	33	43	37	33
ALANL100X1-DED2	1.2	18	14.4	12	10	45	40	35	43	37	33	43	37	33
ALANL100X1-EF10	1.2	18	14.4	12	10	45	40	35	43	37	33	43	37	33
ALANL100X1-EF12	1.2	18	14.4	12	10	45	40	35	43	37	33	43	37	33
ALANL100X1-EF62	1.2	18	14.4	12	10	45	40	35	43	37	33	43	37	33
ALANL100X1-EFD2	1.2	18	14.4	12	10	45	40	35	43	37	33	43	37	33

Part Number	Inductance (uH Min)	Leakage Inductance (uH Max)	Interwinding Capacitance (pF Max)	DC Resistance (Ω Max)		Hi Pot (Vrms)	Weight (g)
				TD+ to TD-	MX+ to MX-		
Test Condition	@100kHz, 0.2V, 8mA DC Bias	@100kHz, 0.1V TD to MX	@100kHz, 0.1V TD to MX	TD+ to TD-	MX+ to MX-	0.5mA/6 sec.	Per Piece
ALANL100X1-DE10	350	0.5	30	1.0	1.5	1500	0.33
ALANL100X1-DE12	350	0.5	30	1.0	1.5	1500	0.33
ALANL100X1-DE62	350	0.5	30	1.5	1.0	1500	0.33
ALANL100X1-DED2	350	0.5	30	1.5 (1-2, 7-8)	1.0 (5-6, 11-12)	1500	0.33
ALANL100X1-EF10	350	0.5	30	1.0	1.5	1500	0.33
ALANL100X1-EF12	350	0.5	30	1.0	1.5	1500	0.33
ALANL100X1-EF62	350	0.5	30	1.5	1.0	1500	0.33
ALANL100X1-EFD2	350	0.5	30	1.5 (1-2, 9-10)	1.0 (7-8, 15-16)	1500	0.33

10/100 BASE-TX Low Profile SMD LAN Transformer Module

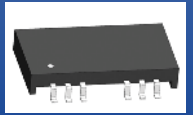

ALANL100X1



12.7 x 7.1 x 2.1 mm
 RoHS/RoHS II Compliant
 MSL = 1

Mechanical Dimensions

D: 12-pin

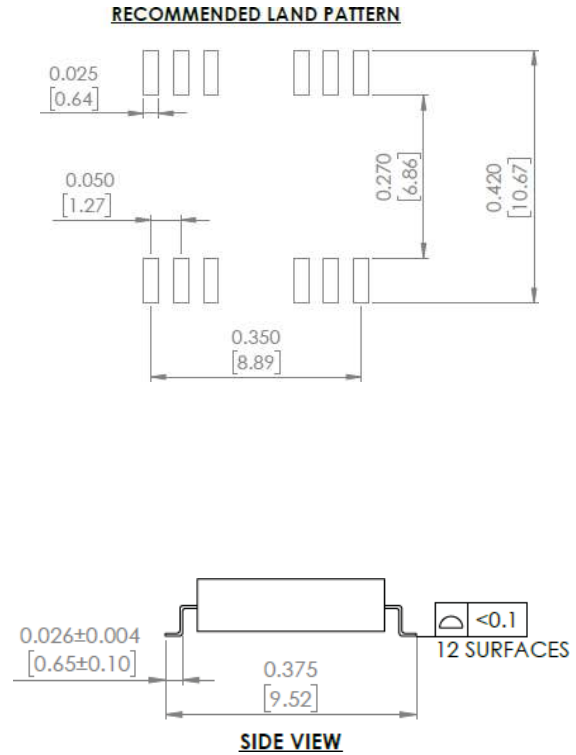
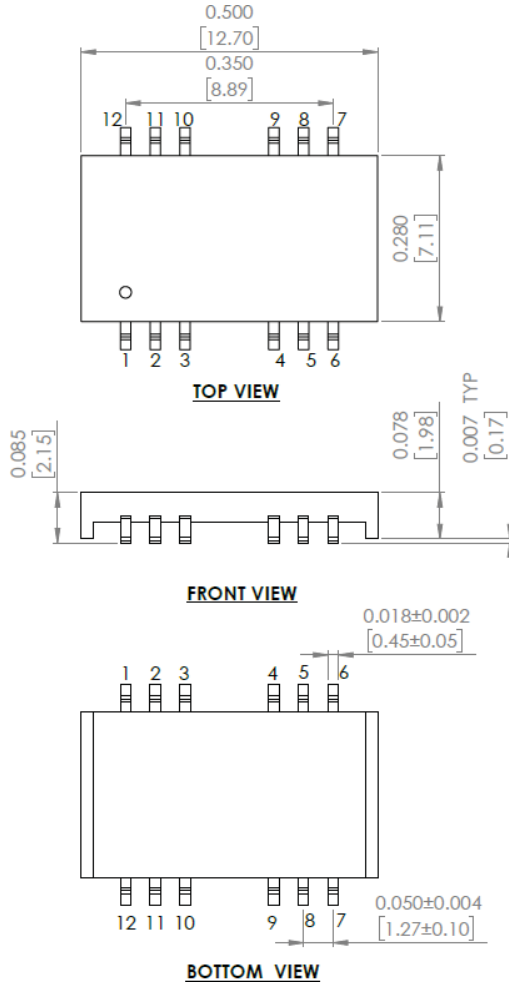

Unless otherwise specified, all tolerances are ±0.25 in mm
 Dimensions: inch/ [mm]



5101 Hidden Creek Ln Spicewood TX 78669
 Phone: 512-371-6159 | Fax: 512-351-8858
 For terms and conditions of sales, please visit:
www.abracon.com

REVISED: 03-02-22

ABRACON IS
 ISO9001-2015
 CERTIFIED

10/100 BASE-TX Low Profile SMD LAN Transformer Module

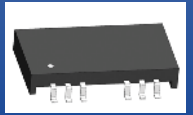

ALANL100X1



12.7 x 7.1 x 2.1 mm
RoHS/RoHS II Compliant
MSL = 1

Mechanical Dimensions

E: 16-pin

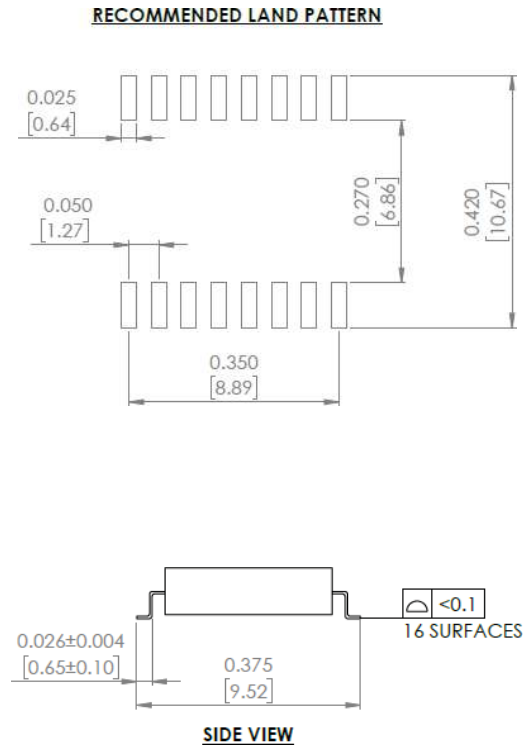
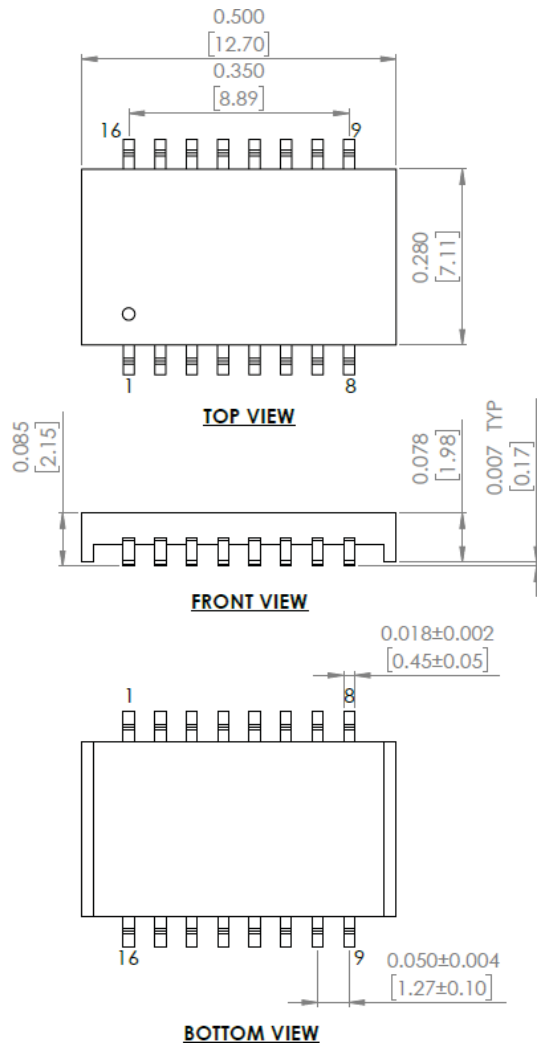

Unless otherwise specified, all tolerances are ±0.25 in mm
Dimensions: inch/ [mm]



5101 Hidden Creek Ln Spicewood TX 78669
Phone: 512-371-6159 | Fax: 512-351-8858
For terms and conditions of sales, please visit:
www.abracon.com

REVISED: 03-02-22

ABRACON IS
ISO9001-2015
CERTIFIED

10/100 BASE-TX Low Profile SMD LAN Transformer Module



ALANL100X1



12.7 x 7.1 x 2.1 mm
 RoHS/RoHS II Compliant
 MSL = 1

Schematics

12-Pin

E10

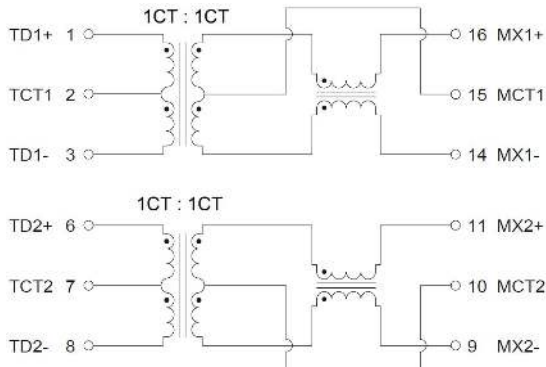

E12

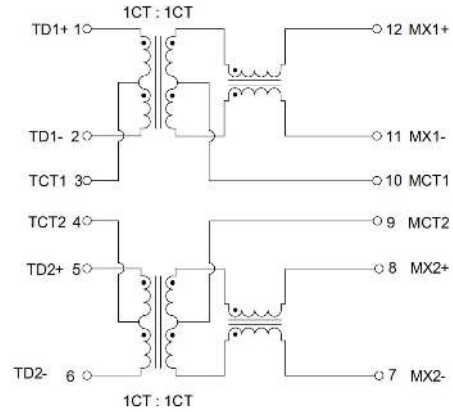

E62

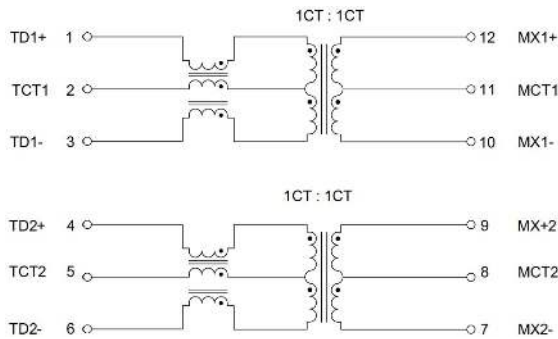

ED2

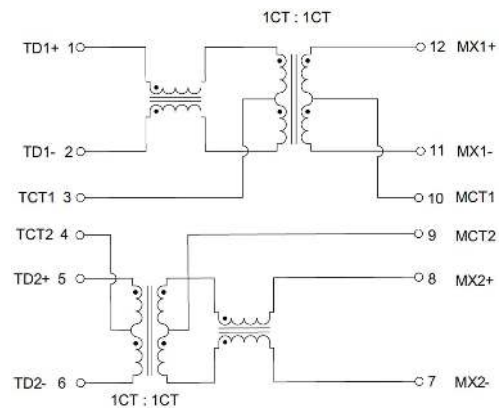

Contact Abracon for additional options.



5101 Hidden Creek Ln Spicewood TX 78669
 Phone: 512-371-6159 | Fax: 512-351-8858
 For terms and conditions of sales, please visit:
www.abracon.com

REVISED: 03-02-22

ABRACON IS
 ISO9001-2015
 CERTIFIED

10/100 BASE-TX Low Profile SMD LAN Transformer Module



ALANL100X1



12.7 x 7.1 x 2.1 mm
 RoHS/RoHS II Compliant
 MSL = 1

Schematics

16-Pin

F10

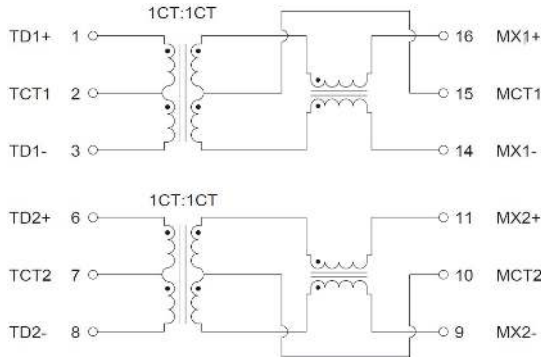

F12

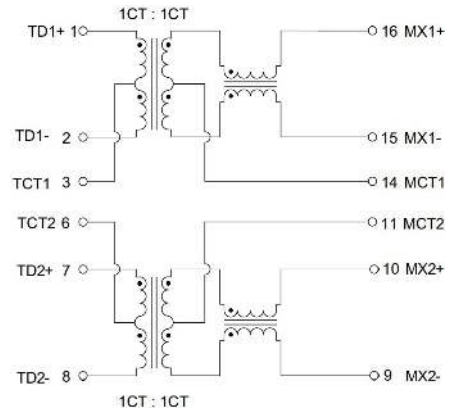

F62

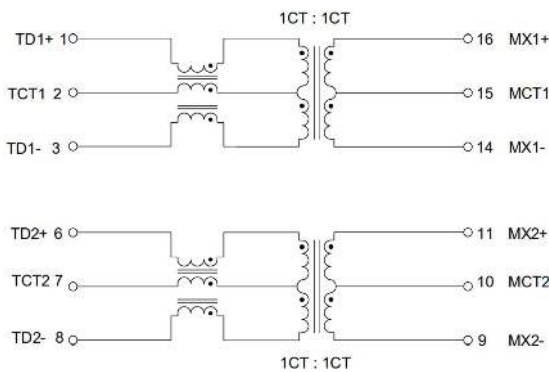

FD2

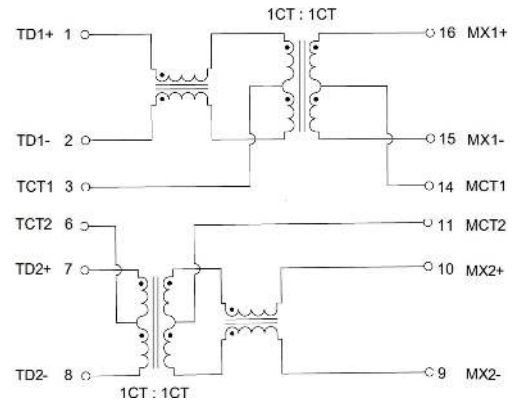

Contact Abracon for additional options.



5101 Hidden Creek Ln Spicewood TX 78669
 Phone: 512-371-6159 | Fax: 512-351-8858
 For terms and conditions of sales, please visit:
www.abracon.com

REVISED: 03-02-22

ABRACON IS
 ISO9001-2015
 CERTIFIED

10/100 BASE-TX Low Profile SMD LAN Transformer Module

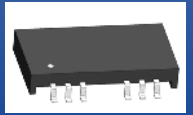

ALANL100X1



12.7 x 7.1 x 2.1 mm
RoHS/RoHS II Compliant
MSL = 1

Reflow Profile

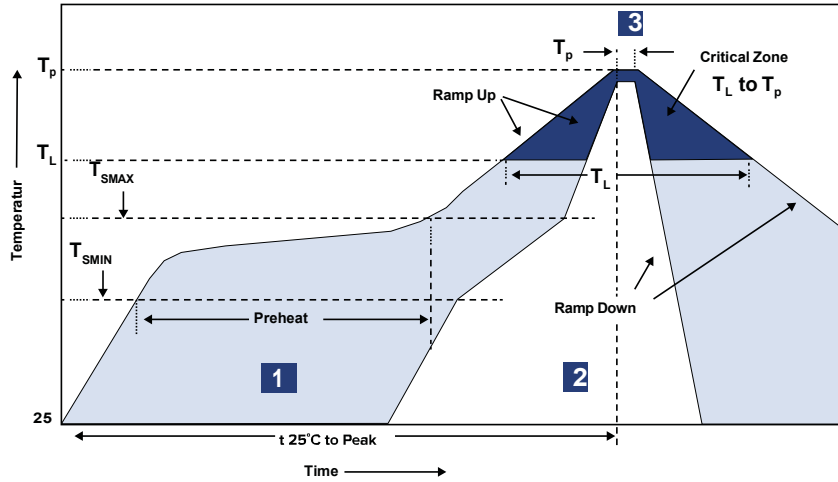

Zone	Description	Temperature	Time
1	Preheat / Soak	$T_{SMIN} \sim T_{SMAX}$ 150°C ~ 200°C	60 ~ 120 sec.
2	Reflow	T_L 217°C	60 ~ 150 sec.
3	Peak heat	T_P 240°C ± 5°C	20 ~ 40 sec.

10/100 BASE-TX Low Profile SMD LAN Transformer Module

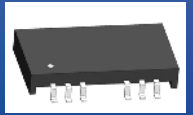

ALANL100X1



12.7 x 7.1 x 2.1 mm
RoHS/RoHS II Compliant
MSL = 1

Packaging

Tape and Reel: 2,000 pcs
Pieces per Carton: 20,000 pcs/box
T&R per Carton: 10 T&R/box
Weight per Carton: 13.3kg
Weight per Piece: 0.33g

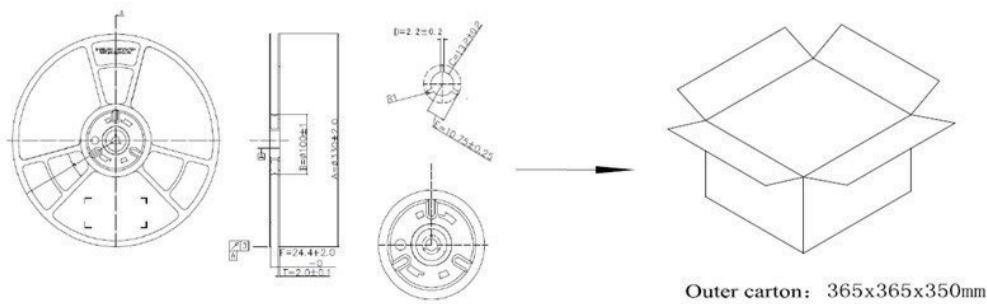
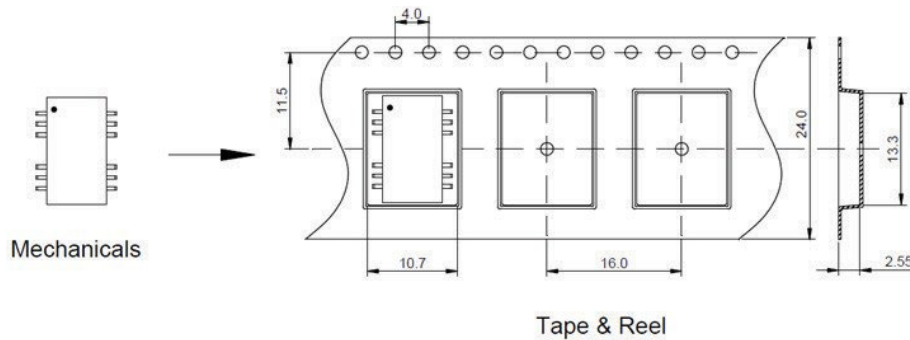

Dimensions: mm

ATTENTION: Abracon LLC's products are COTS - Commercial-Off-The-Shelf products; suitable for Commercial, Industrial and, where designated, Automotive Applications. Abracon's products are not specifically designed for Military, Aviation, Aerospace, Life-dependent Medical applications or any application requiring high reliability where component failure could result in loss of life and/or property. For applications requiring high reliability and/or presenting an extreme operating environment, written consent and authorization from Abracon LLC is required. Please contact Abracon LLC for more information.



5101 Hidden Creek Ln Spicewood TX 78669
Phone: 512-371-6159 | Fax: 512-351-8858
For terms and conditions of sales, please visit:
www.abracon.com

REVISED: 03-02-22

ABRACON IS
ISO9001-2015
CERTIFIED