

DO NOT SCALE FROM THIS PRINT

TABLE 1	
No. OF POS.	MAX COPLANARITY
0-35	.004 [.10]
40-50	.006 [.15]

FSI-1XX-03-X-D-X-XX-XX-X-XX

**PACKAGING** (SEE NOTES 11 & 12)  
 BLANK: TUBES (SEE NOTE 10)  
 -TR: TAPE & REEL PACKAGING  
 -FR: FULL REEL QTY TAPE & REEL

**No OF POSITIONS**  
 THREADED: -10, -20, -30, -40, -50  
 NON-THREADED: -05 THRU -50  
 [IN MULTIPLES OF 5] (SEE NOTE 8)

**BODY HEIGHT**  
 -03: 3mm HEIGHT  
 (USE C-133-01-X)

**PLATING**  
 -G: GOLD  
 (USE C-133-01-G)  
 -H: HEAVY GOLD  
 (USE C-133-01-H)

**ROW SPECIFICATION**  
 -D: DOUBLE  
 (USE FSI-XX-03-D)

**PICK & PLACE**

-K: POLYAMIDE FILM PAD  
 (USE K-500-300) (SEE FIGS 4 & 5, SHEET 3)

**OPTION**

-SD: SCREW DOWN OPTION  
 (USE THS-4-40-.560-XX) (AVAILABLE ON 10, 20 & 30 POS. WITH -AD ONLY; SEE SHEET 4) (SEE NOTE 7)

**OPTION UNAVAILABLE WITH ANY THREADED INSERT OPTION**

**ALIGNMENT PIN OPTION**

-AT: TOP SIDE (USE FSI-XX-03-D-AT-X)  
 -AB: BOTTOM SIDE (USE FSI-XX-03-D-AB-X)  
 -AD: DUAL (TOP & BOTTOM)  
 (USE FSI-XX-03-D-AD-X, SEE FIG 2)  
 \*\*LC: LOCKING CLIP  
 BLANK FOR NO ALIGNMENT PIN

**THREADED INSERT OPTION**

-E: THREADED INSERT (ENGLISH)  
 (USE INS-C-2-56-100, SEE FIG 3, SHT 2)  
 -M: THREADED INSERT (METRIC)  
 (USE INS-C-M2-100-N, SEE FIG 3, SHT 2)  
 LEAVE BLANK FOR NO THREADED INSERT

\* = NOT RELEASED FOR PRODUCTION  
 \*\* = NOT TOOLED

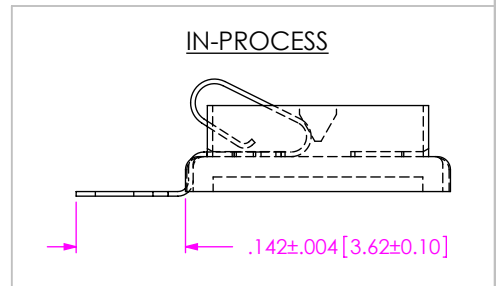
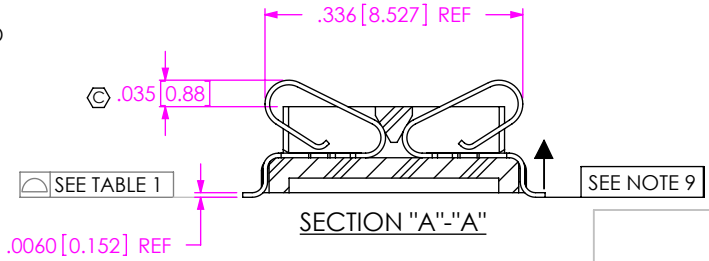
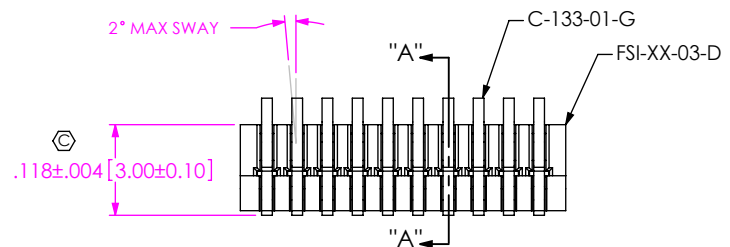
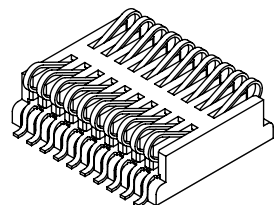
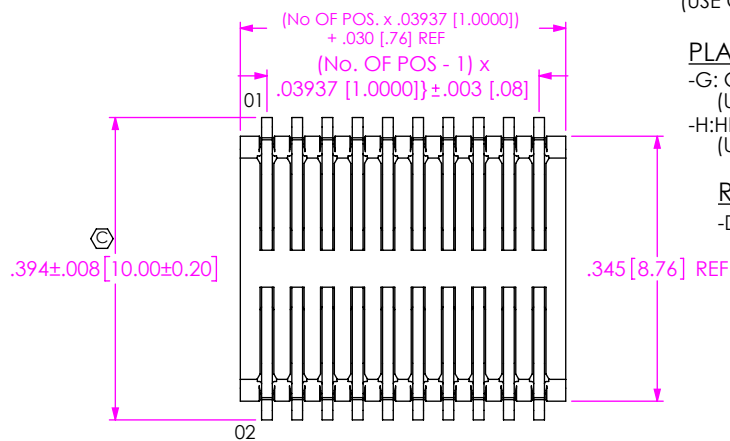



FIG 1  
 FSI-110-03-G-D SHOWN

NOTES:

- ⊕ REPRESENTS A CRITICAL DIMENSION.
- MINIMUM PUSHOUT FORCE: 12 oz.
- LOAD INSERTS IN DIRECTION OF THE ARROW USING HAND LOAD THERMAL INSERTION PRESS.
- THREADED INSERT MUST BE ABLE TO HANDLE 20 in-oz's OF TORQUE MIN WITHOUT ROTATING OR "LOOSENING".
- THREADED INSERT RETENSION TO BE 7lbs. MIN.
- THREADED INSERT TO BE FLUSH TO .005[0.13] BELOW HOUSING SURFACE.
- SD OPTION: RETENTION TO BE 3lb MIN AND MUST WITHSTAND 6 in-oz's OF TORQUE.
- APPLICATIONS REQUIRING 40-50 POSITIONS WITHOUT THREADED INSERTS, PLEASE CONTACT SAMTEC INTERCONNECT PROCESSING GROUP.
- MAXIMUM ALLOWABLE SHEAR BURR: .003 [.08], IN DIRECTION SHOWN.
- TUBES ARE STANDARD PACKAGING
- ORDERS WILL BE PACKAGED ACCORDING TO THE SAMTEC PACKAGING EFFICIENCY STANDARDS (SPES) FOUND ON WWW.SAMTEC.COM
- ATTACH LABEL -4X2 TO EACH REEL

UNLESS OTHERWISE SPECIFIED, DIMENSIONS ARE IN INCHES. TOLERANCES ARE: DECIMALS ANGLES .XX: ±.01 [.2] 2° .XXX: ±.005 [.13] .XXXX: ±.0020 [.050]	* PROPRIETARY NOTE * THIS DOCUMENT CONTAINS CONFIDENTIAL AND PROPRIETARY INFORMATION AND ALL DESIGN, MANUFACTURING, REPRODUCTION, USE, PATENT RIGHTS AND SALES RIGHTS ARE EXPRESSLY RESERVED BY SAMTEC, INC. THIS DOCUMENT SHALL NOT BE DISCLOSED, IN WHOLE OR PART, TO ANY UNAUTHORIZED PERSON OR ENTITY NOR REPRODUCED, TRANSFERRED OR INCORPORATED IN ANY OTHER PROJECT IN ANY MANNER WITHOUT THE EXPRESS WRITTEN CONSENT OF SAMTEC, INC.	 520 PARK EAST BLVD, NEW ALBANY, IN 47150 PHONE: 812-944-6733 FAX: 812-948-5047 e-Mail: info@SAMTEC.com code: 55322

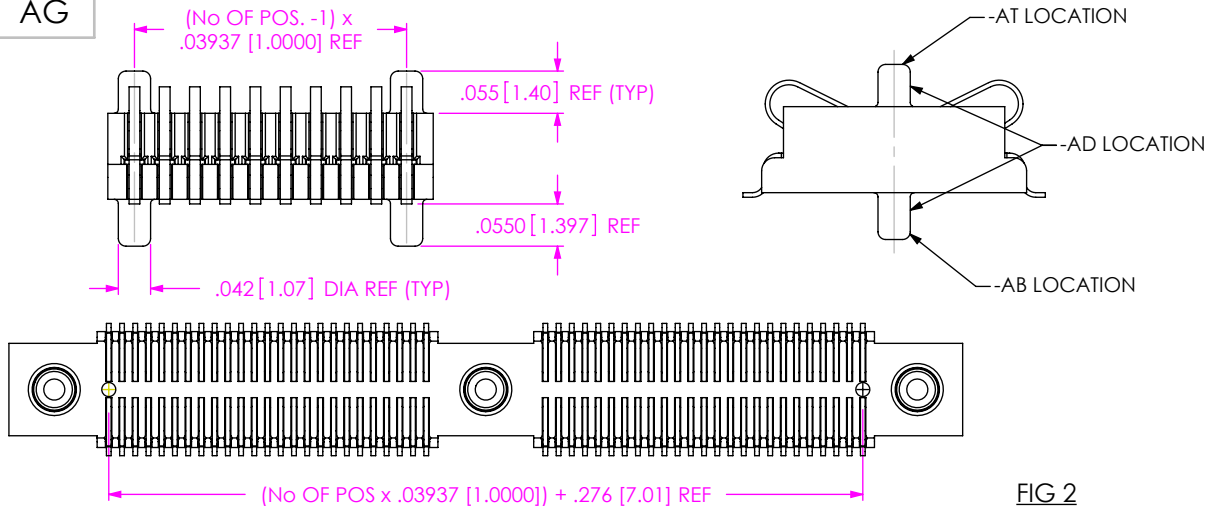
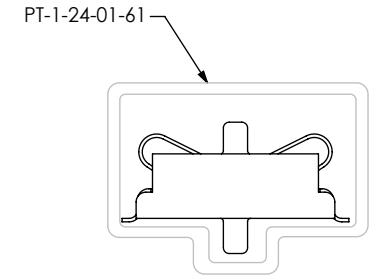
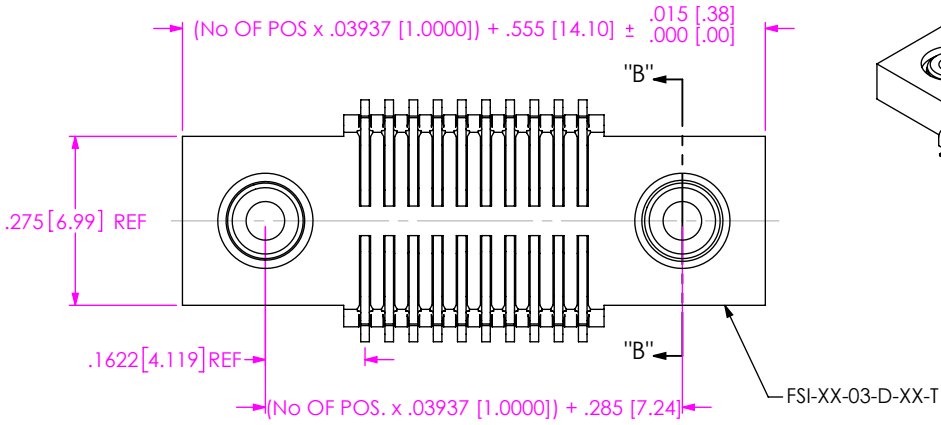

FIG 2  
ALIGNMENT PIN OPTIONS  
(FSI-110-03-G-D-AD SHOWN)



NOTE: **PACKAGING VIEW**  
PARTS ARE TO BE PACKAGED IN PT-1-24-01-61 TUBES WITH TWO TP-03 PLUGS PER TUBE.

ALIGNMENT PIN OPTION  
FOR -40- & -50 WITH -M OR -E OPTION  
(SHOWN: FSI-150-03-G-D-M-AD)



-M & -E: THREADED OPTIONS  
(FSI-110-03-G-D-M SHOWN)  
(EQUATIONS APPLY TO -10, -20 & -30 ONLY)

TABLE 2: INSERT OPTION

OPTION	INSERT	THREAD
-E	INS-C-2-56-100	2 x 56
-M	INS-C-M2-100-N	M2.0 x 4

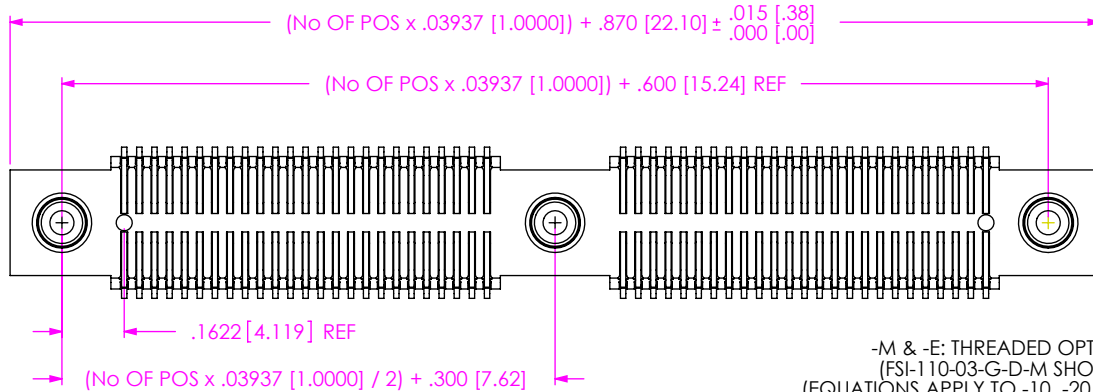
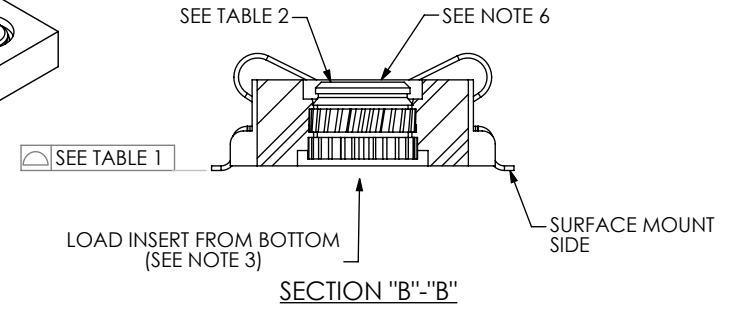

FIG 3  
FOR -40- & -50 WITH -M OR -E OPTION  
(SHOWN: FSI-150-03-X-D-M-AD)

**PROPRIETARY NOTE**  
THIS DOCUMENT CONTAINS CONFIDENTIAL AND PROPRIETARY INFORMATION AND ALL DESIGN, MANUFACTURING, REPRODUCTION, USE, PATENT RIGHTS AND SALES RIGHTS ARE EXPRESSLY RESERVED BY SAMTEC, INC. THIS DOCUMENT SHALL NOT BE DISCLOSED, IN WHOLE OR PART, TO ANY UNAUTHORIZED PERSON OR ENTITY NOR REPRODUCED, TRANSFERRED OR INCORPORATED IN ANY OTHER PROJECT IN ANY MANNER WITHOUT THE EXPRESS WRITTEN CONSENT OF SAMTEC, INC.



520 PARK EAST BLVD, NEW ALBANY, IN 47150  
PHONE: 812-944-6733 FAX: 812-948-5047  
e-Mail: info@SAMTEC.com code: 55322

DO NOT SCALE DRAWING

SHEET SCALE: 4:1

DESCRIPTION: 1mm SINGLE ELEMENT INTERFACE

DWG. NO. **FSI-1XX-03-X-D-X-XX-XX-X-XX**

BY: BRATCHER 1/27/99 SHEET 2 OF 4

FIG 4

-K: POLYAMIDE FILM PAD  
(.098 [2.50] DIA PAD USED ON ALL POSITIONS EXCEPT -40 & -50 POSITIONS WITH THREADED INSERT OPTION)

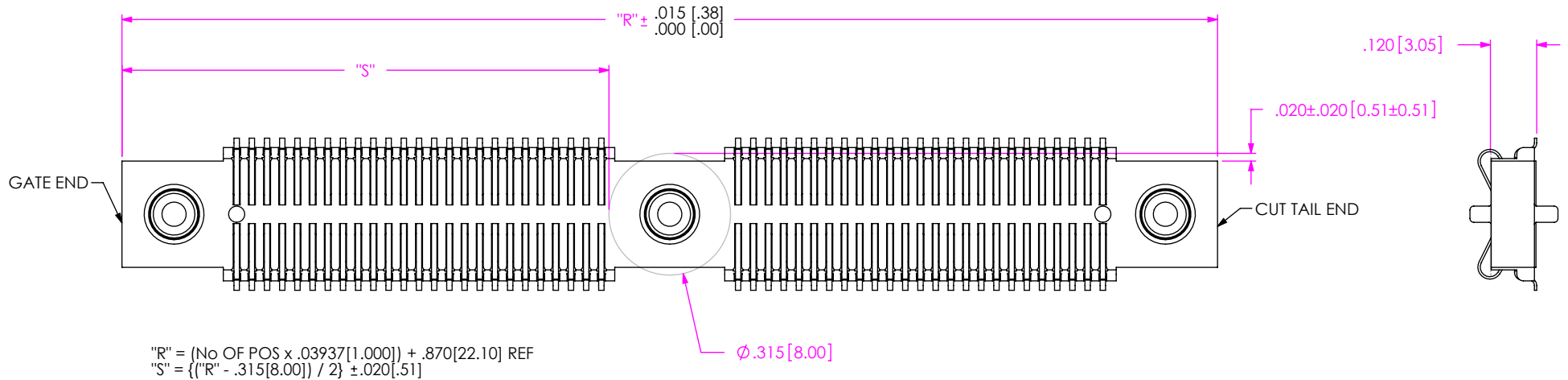
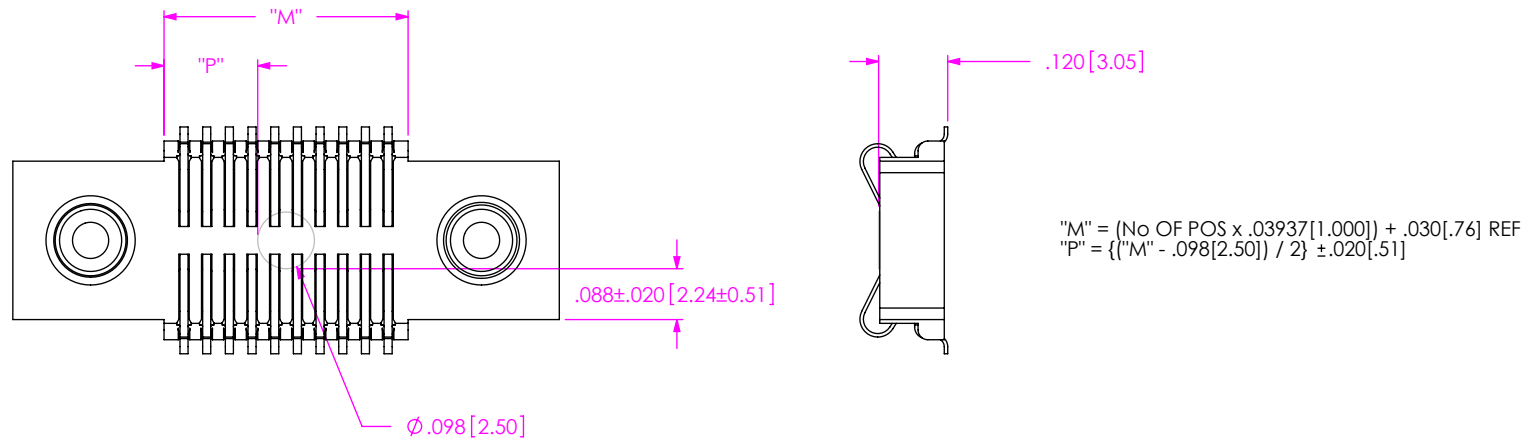
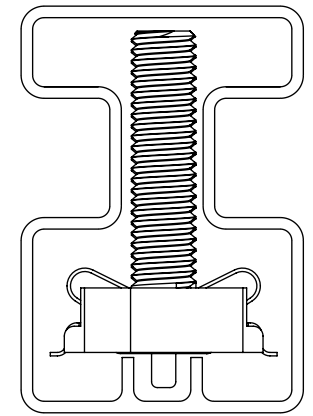
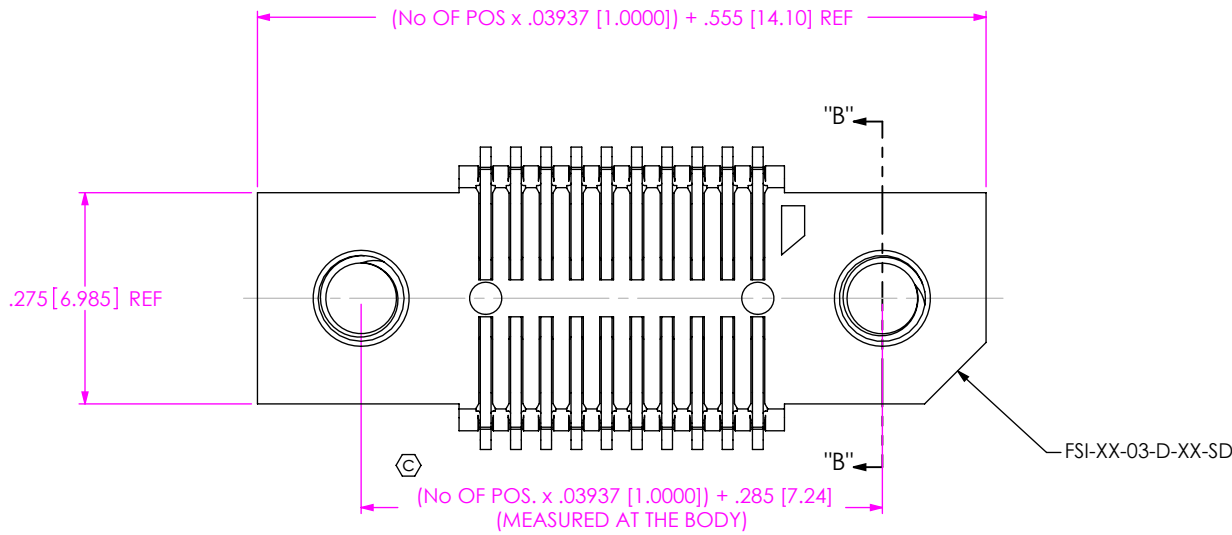

FIG 5  
-K: POLYAMIDE FILM PAD  
(.315 [8.00] DIA PAD USED ONLY ON -40 & -50 POSITIONS WITH THREADED INSERT OPTION)

<p>DO NOT SCALE DRAWING</p> <p>SHEET SCALE: 3:1</p>	<p><b>PROPRIETARY NOTE</b></p> <p>THIS DOCUMENT CONTAINS CONFIDENTIAL AND PROPRIETARY INFORMATION AND ALL DESIGN, MANUFACTURING, REPRODUCTION, USE, PATENT RIGHTS AND SALES RIGHTS ARE EXPRESSLY RESERVED BY SAMTEC, INC. THIS DOCUMENT SHALL NOT BE DISCLOSED, IN WHOLE OR PART, TO ANY UNAUTHORIZED PERSON OR ENTITY NOR REPRODUCED, TRANSFERRED OR INCORPORATED IN ANY OTHER PROJECT IN ANY MANNER WITHOUT THE EXPRESS WRITTEN CONSENT OF SAMTEC, INC.</p>	<p><b>samtec</b></p> <p>520 PARK EAST BLVD, NEW ALBANY, IN 47150 PHONE: 812-944-6733 FAX: 812-948-5047 e-Mail: info@SAMTEC.com code: 55322</p>
	<p>DESCRIPTION:</p> <p>1mm SINGLE ELEMENT INTERFACE</p>	
	<p>DWG. NO.</p> <p><b>FSI-1XX-03-X-D-X-XX-XX-X-XX</b></p>	
	<p>BY: BRATCHER 1/27/99</p>	<p>SHEET 3 OF 4</p>



PACKAGING VIEW

NOTE:

PARTS ARE TO BE PACKAGED IN PT-FSI001-03-SD TUBES WITH TWO TP-03 PLUGS PER TUBE.

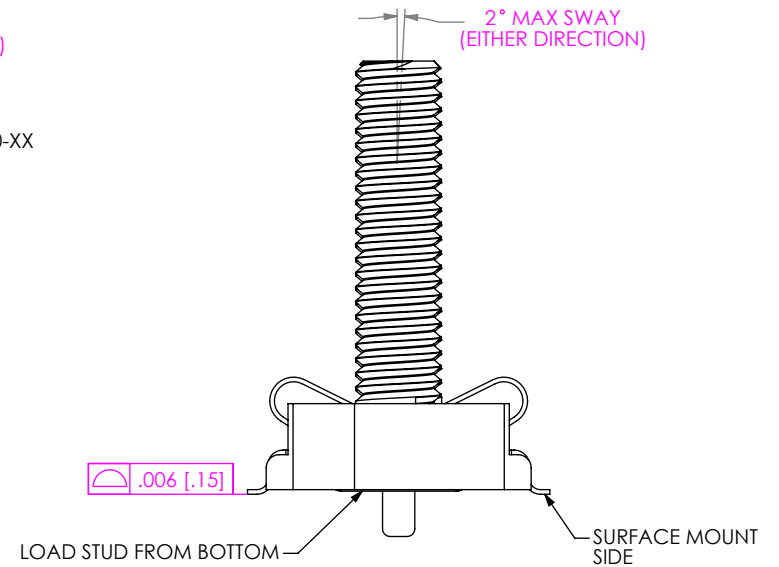
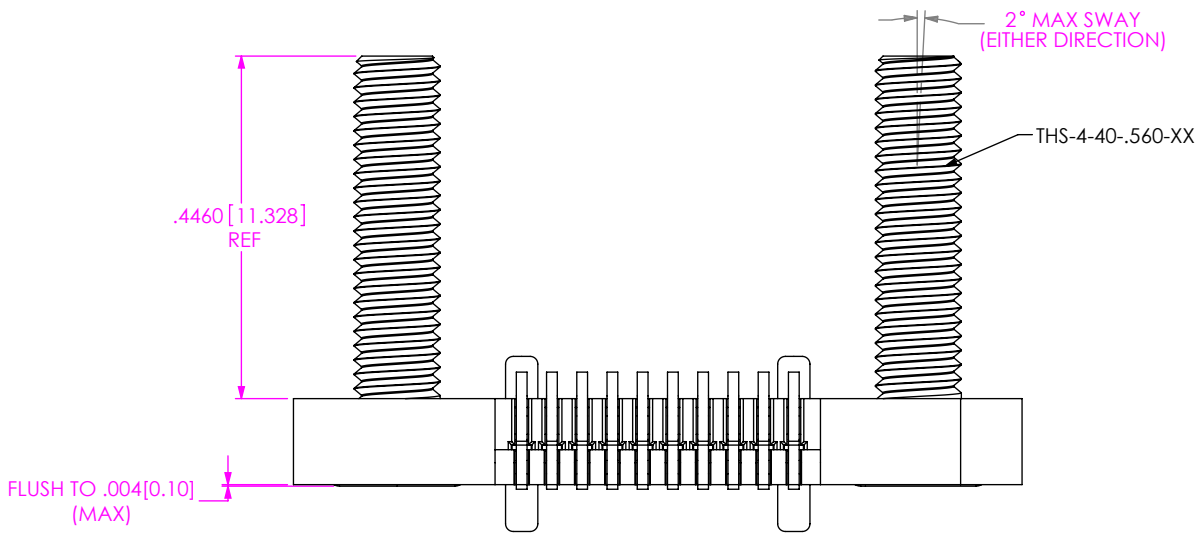

**FIG 6**  
 -SD: SCREW DOWN OPTION  
 (FSI-110-03-G-D-AD-SD SHOWN)  
 (AVAILABLE IN POS -10, -20 & -30 WITH -AD OPTION ONLY)  
**OPTION UNAVAILABLE WITH  
 ANY THREADED INSERT OPTION**

**PROPRIETARY NOTE**  
 THIS DOCUMENT CONTAINS CONFIDENTIAL AND PROPRIETARY INFORMATION AND ALL DESIGN, MANUFACTURING, REPRODUCTION, USE, PATENT RIGHTS AND SALES RIGHTS ARE EXPRESSLY RESERVED BY SAMTEC, INC. THIS DOCUMENT SHALL NOT BE DISCLOSED, IN WHOLE OR PART, TO ANY UNAUTHORIZED PERSON OR ENTITY NOR REPRODUCED, TRANSFERRED OR INCORPORATED IN ANY OTHER PROJECT IN ANY MANNER WITHOUT THE EXPRESS WRITTEN CONSENT OF SAMTEC, INC.



520 PARK EAST BLVD, NEW ALBANY, IN 47150  
 PHONE: 812-944-6733 FAX: 812-948-5047  
 e-Mail: info@SAMTEC.com code: 55322

DO NOT SCALE DRAWING

SHEET SCALE: 3:1

DESCRIPTION:  
 1mm SINGLE ELEMENT INTERFACE

DWG. NO.  
**FSI-1XX-03-X-D-X-XX-XX-X-XX**

BY: BRATCHER 1/27/99

SHEET 4 OF 4