

THIS COPY IS PROVIDED ON A RESTRICTED BASIS AND IS NOT TO BE USED IN ANY WAY DETRIMENTAL TO THE INTERESTS OF PANDUIT CORP.

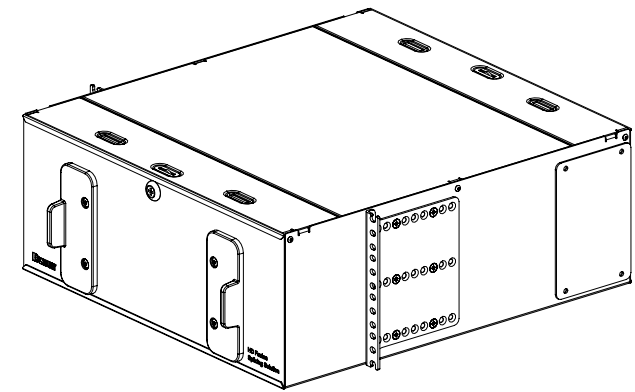
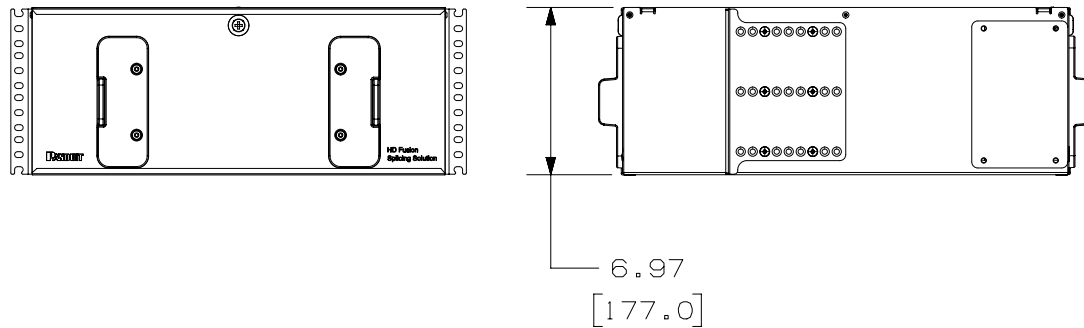
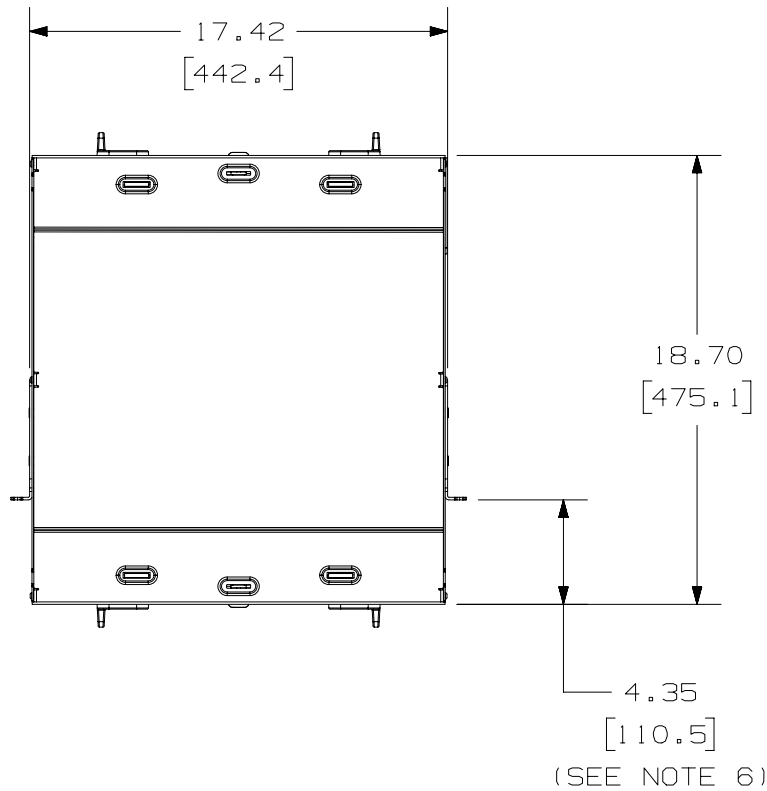

- NOTES:
- VISIT OUR ON-LINE CATALOG AT WWW.PANDUIT.COM FOR A LIST OF CURRENT PARTS APPLICABLE FOR USE WITH THIS PRODUCT.
  - DIMENSIONS IN [ ] ARE METRIC.
  - ALL MATERIALS AND COMPONENTS USED MEET THE MATERIAL RESTRICTIONS OF RoHS (EUROPEAN DIRECTIVE 2011/65/EU ON THE RESTRICTION OF HAZARDOUS SUBSTANCES) AS PROPOSED BY THE RoHS TECHNICAL ADAPTATION COMMITTEE.
  - WEIGHT: 32 lbs (14.5 kg)
  - DIMENSIONS ARE FOR REFERENCE ONLY
  - MOUNTING BRACKETS ARE ADJUSTABLE IN .5 [12.7] INCREMENTS
  - DESIGNED TO ACCOMODATE PANDUIT FST48 SPLICING TRAYS
    - SIX SPLICING TRAYS FOR UP TO 864 RIBBONIZED FIBERS (72 RIBBONS)
    - TWELVE SPLICING TRAYS FOR UP TO 576 SINGLE FIBERS
    - SPLICING TRAYS NOT INCLUDED

PART NUMBER		FRMHSS-4RU		
TITLE		4RU HD FUSION SPLICE ENCLOSURE		
ITEM REVISION NAME		CUSTOMER DRAWING		
DATASET FILE NAME		17F088AP/05		
MATERIAL		ENCLOSURE BODY: STEEL		
DRAWING NUMBER		17F088AP-DC		
THIRD ANGLE PROJECTION				
REV	DATE	BY	CHK	SCALE
00	08/08/18	SAT	BONS	1:8
DESCRIPTION		ECN	SHEET 1 OF 1	
INITIAL RELEASE		17F088AP	A	

A-SIZE CUSTOMER

2

1

2

1