

LA3161



ON Semiconductor®

www.onsemi.com

Monolithic Linear IC 2-Channel Preamplifier for Car Stereo

Features

- On-chip 2 preamplifiers
- Good ripple rejection owing to on-chip voltage regulator
- Minimum number of external parts required
- Low noise
- 8-pin SIP package facilitating easy mounting
- Pin-compatible with LA3160

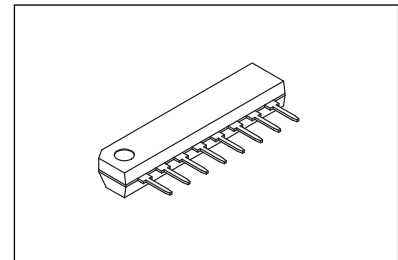

SIP8 22x4.5 / SIP8

Specifications

Absolute Maximum Ratings at $T_a = 25^\circ\text{C}$

Parameter	Symbol	Conditions	Ratings	Unit
Maximum Supply Voltage	$V_{CC\text{ max}}$		18	V
Allowable Power Dissipation	$P_d\text{ max}$		200	mW
Operating Temperature	T_{opr}		-20 to +75	$^\circ\text{C}$
Storage Temperature	T_{stg}		-40 to +125	$^\circ\text{C}$

Stresses exceeding those listed in the Maximum Ratings table may damage the device. If any of these limits are exceeded, device functionality should not be assumed, damage may occur and reliability may be affected.

Recommended Operating Conditions at $T_a = 25^\circ\text{C}$

Parameter	Symbol	Conditions	Ratings	Unit
Supply Voltage	V_{CC}		9	V
Load Resistance	P_L		10k	Ω

Functional operation above the stresses listed in the Recommended Operating Ranges is not implied. Extended exposure to stresses beyond the Recommended Operating Ranges limits may affect device reliability.

Electrical Characteristics at $T_a = 25^\circ\text{C}$, $V_{CC} = 9\text{V}$, $R_L = 10\text{k}\Omega$, $R_g = 600\Omega$, $f = 1\text{kHz}$, NAB

Parameter	Symbol	Conditions	Ratings			Unit
			min	typ	max	
Current Dissipation	I_{CC}			6.5	8.0	mA
Voltage Gain	VG	Closed loop		35		dB
		Open loop, $V_O = 0.77\text{V}$	70	78		dB
Output Voltage	V_O	THD = 1%	1.0	1.3		V
Total Harmonic Distortion	THD	$V_O = 0.5\text{V}$		0.05	0.30	%
Input Resistance	r_i		70k	100k		Ω
Equivalent Input Noise Voltage	V_{NI}	$R_g = 2.2\text{k}\Omega$		1.2	2.0	μF
Crosstalk	CT	$R_g = 2.2\text{k}\Omega$	-50	-65		dB
Ripple Rejection	Rr			-40		dB

Product parametric performance is indicated in the Electrical Characteristics for the listed test conditions, unless otherwise noted. Product performance may not be indicated by the Electrical Characteristics if operated under different conditions.

ORDERING INFORMATION

See detailed ordering and shipping information on page 7 of this data sheet.

LA3161

Package Dimensions

unit : mm

SIP8 22x4.5 / SIP8
CASE 127AG
ISSUE O

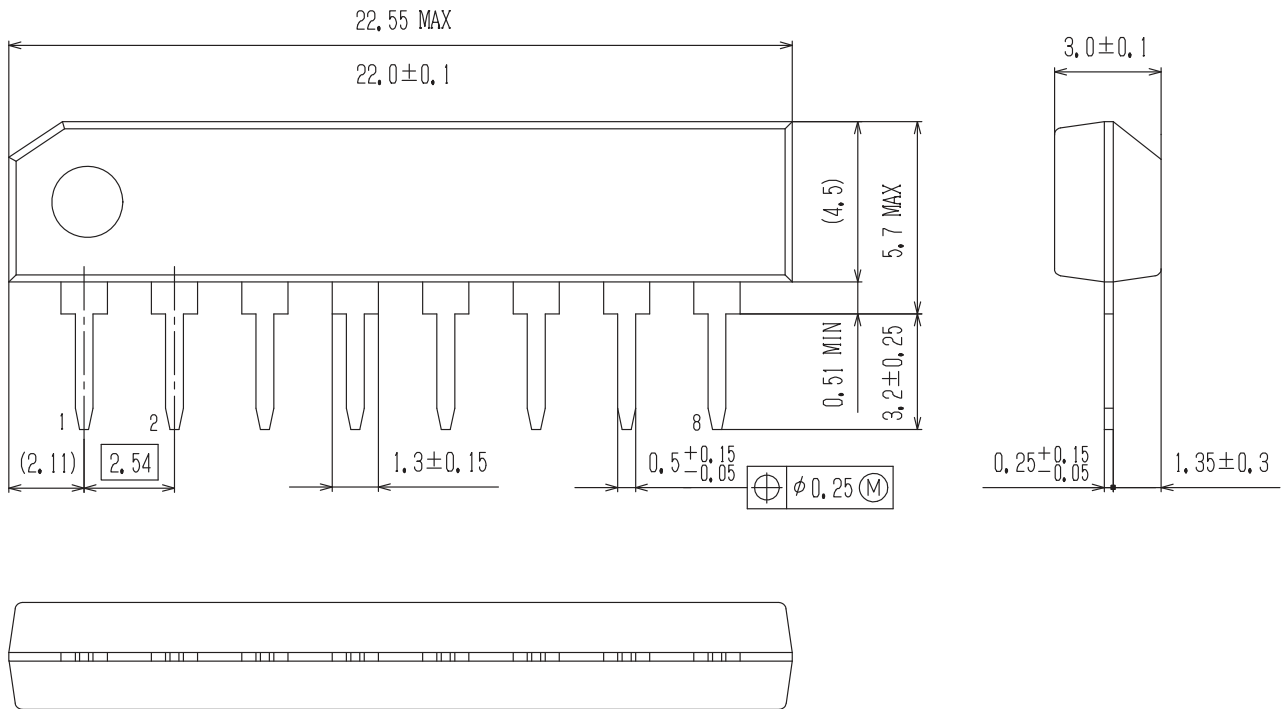

Block Diagram

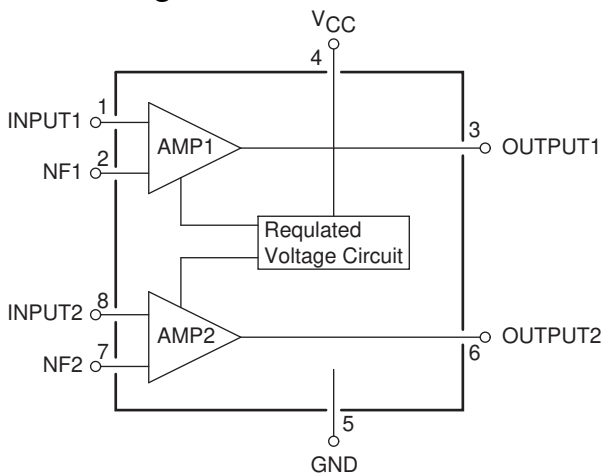

LA3161

Test Circuit1 : V_O , V_G , THD, I_{CC} , r_i

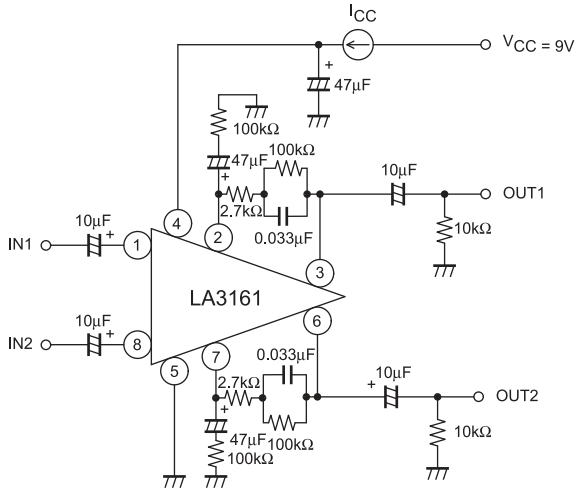

Test Circuit2 : V_{G_O}

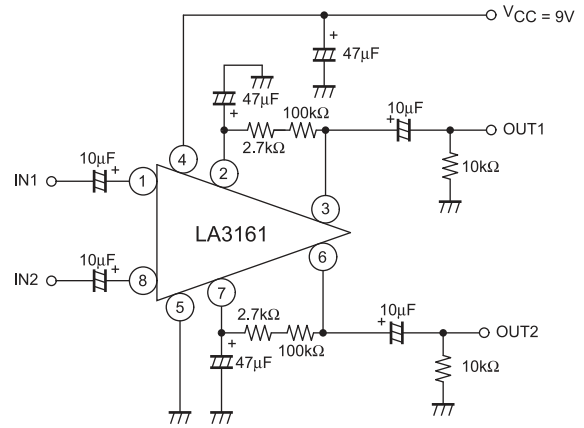

Test Circuit3 : Noise

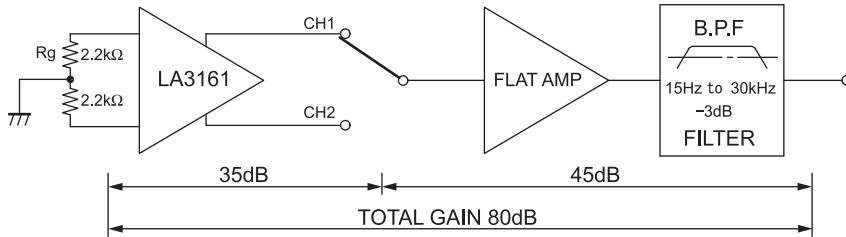

Sample Application Circuit 1 : Pre-amplifier for Car Stereo

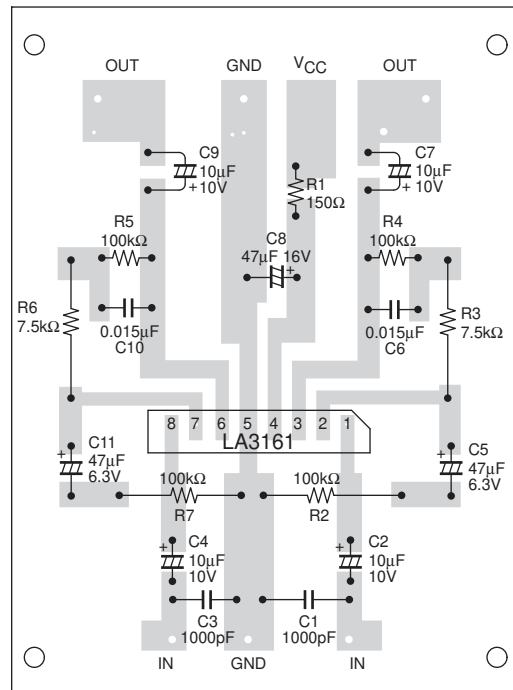
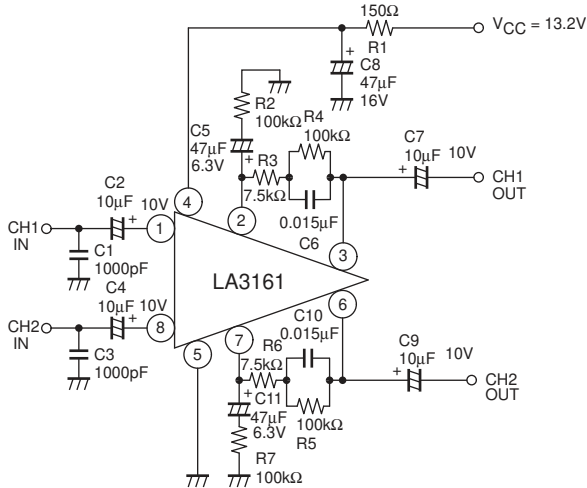

Function of External Parts

C₂, C₄ are input coupling capacitors. In NAB equalizer amplifier, the gain at low frequencies is high and 1/f noise inside the IC is emphasized as output noise. Therefore, if the reactance of capacitor at low frequencies is increased, the dependence of 1/f noise on the signal source resistance causes the output noise voltage to deteriorate, and the value of reactance must be made small enough as compared with the signal source resistance. C₂, C₄ also influence the operation start time and the adequate value of these capacitors is 10μF. (Since C₂, C₄ of less than 4.7μF make the operation start time longer, use C₂, C₄, of 4.7μF or more).

C₅, C₁₁ are NF capacitors. The lower cut-off frequency depends on the value of these capacitors.

If the lower cut-off frequency is taken as f_L :

$$C5 (C11) = 1/2\pi \cdot f_L \cdot R2 (R7)$$

If the value of this capacitor is made larger, the operation start time of amplifier is more delayed. The adequate value of capacitor is 47μF.

The frequency characteristic of the equalizer amplifier depends on C₆ and R₄, R₃ (C₁₀ and R₅, R₆).

The time constants to obtain the standard NAB characteristic are as shown below.

Tape speed	9.5cm/s	4.75cm/s
C6 (R3 + R4)	3180μs	1590μs
R3 C6	90μs	120μs

C₈ is bias capacitor for the power line. C₈ of 47μF is inserted at a point as close to the power supply pin (pin 4) as possible.

C₁, C₃ are for preventing radio interference in the strong electric field, interference attributable to engine noise, and blocking oscillation at the time of large amplitude operation. The adequate value of C₁, C₃ is approximately 1000pF.

C₇, C₉ are output coupling capacitors. The adequate value of C₇, C₉ is 10μF.

NAB element and determination of gain

Since the DC feedback is provided by R₁, R₂ of NAB element, which brings about DC output potential at pins 3, 6, it is impossible to change the value of R₁, R₂ of NAB element greatly. Therefore, when determining the gain, change R_{NF} with R₁, R₂, C₁ (NAB element) kept constant.

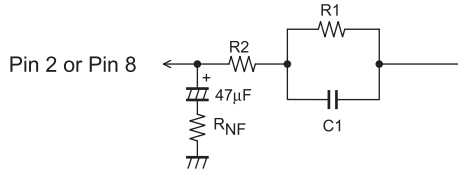

(1) How to obtain R_{NF}

Impedance Z of NAB element is

$$Z = \frac{1}{1/R1 + j\omega C1} + R2$$

$$= (R1 + R2) \left\{ \frac{1 + j\omega C1 \{R1 R2 / (R1 + R2)\}}{1 + j\omega C1 R1} \right\}$$

For a general negative feedback amplifier circuit, A = A_o / (1 + A_oβ) applies, and Z = A · R_{NF} is obtained under conditions of A_o >> A, A >> 1 (β = R_{NF} / (R_{NF} + Z), A_o = open-loop gain, A = feedback gain).

Therefore, we can use an approximation of R_{NF} = Z/A.

A = (VG for 1kHz) times, (Set R₁, R₂ at approximately 100kΩ)

Each time constant of NAB characteristic.

Tape speed	9.5cm/s	4.75cm/s
T1 C1, R1	3180μs	1590μs
T2 C1 (R1//R2)	90μs	120μs

(2) Examples of NAB Constants

(a) Tape speed : 9.5cm/s. (8 tracks)

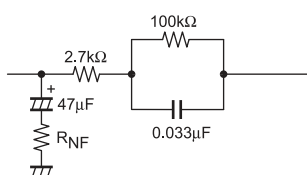

VG : R_{NF} (VG/f = 1kHz)

VG	30	35	40	dB
R _{NF}	180	100	56	Ω

(b) Tape speed : 4.75cm/s. (cassette)

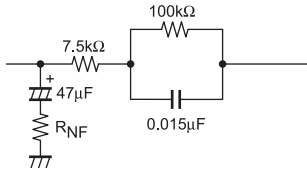

VG : RNF

VG	30	35	40	dB
RNF	440	240	130	Ω

(c) Flat amplifier

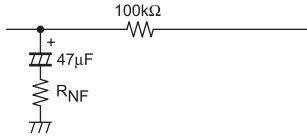

VG : RNF

VG	30	35	40	dB
RNF	3.2	1.8	1	kΩ

Proper cares in using IC

1. Maximum Rating

If the IC is used in the vicinity of the maximum rating, even a slight variation in conditions may cause the maximum rating to be exceeded, thereby leading to a breakdown. Allow an ample margin of variation for supply voltage, etc. and use the IC in the range where the maximum rating is not exceed.

2. Short between pins

If the supply voltage is applied when the space between pins is shorted, a breakdown or deterioration may occur. When installing the IC on the board or applying the supply voltage, make sure that the space between pins is not shorted with solder, etc.

3. Breakdown of IC attributable to inverted insertion

If the IC is inserted inversely and operated, the IC may suffer from something unusual, thereby leading to a breakdown or deterioration of the IC. When installing the IC on the board or operating the IC, check the marked surface of IC.

Proper cares to be taken for obtaining optimum operation of IC

- Set DC resistance of R₁, R₂ of NAB element at approximately 100kΩ.
- Determine the gain by changing R_{NF} without chaging NAB constant (Refer to Examples of NAB constant.).

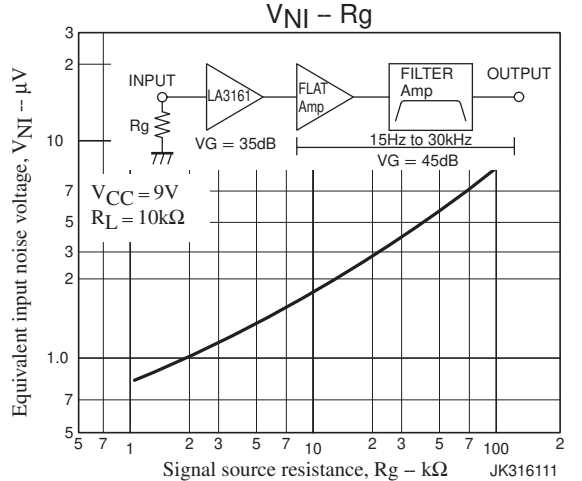
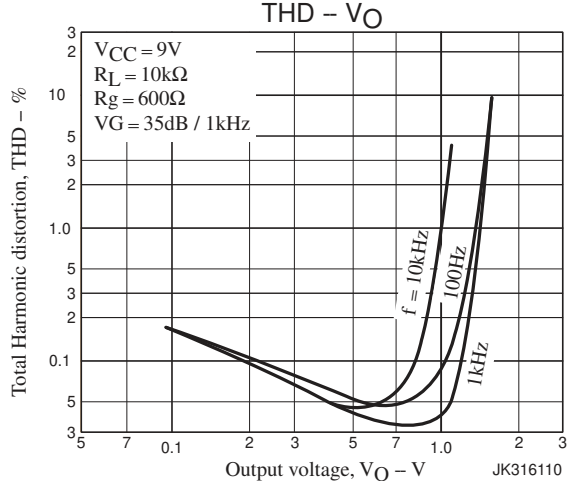
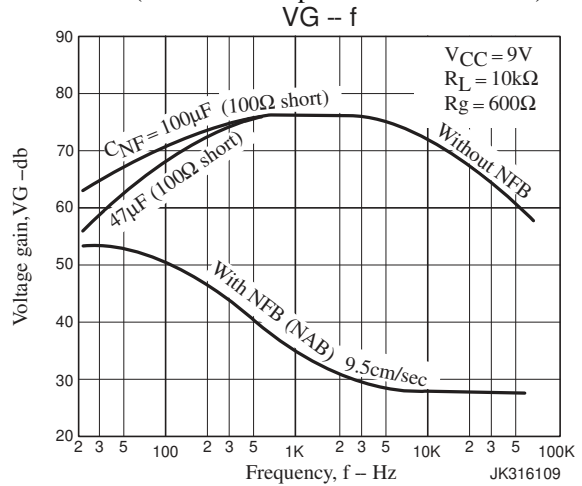
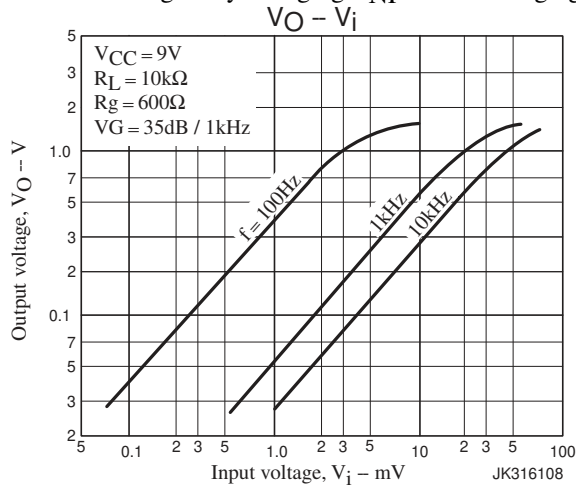

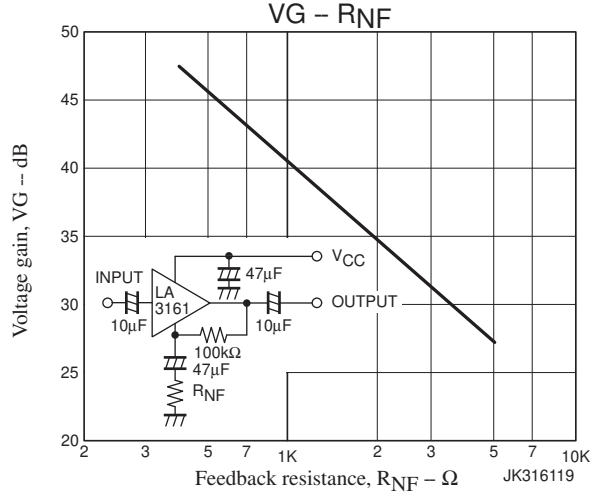
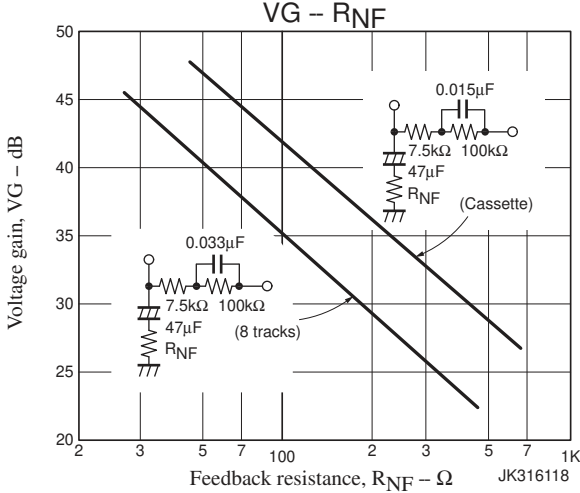
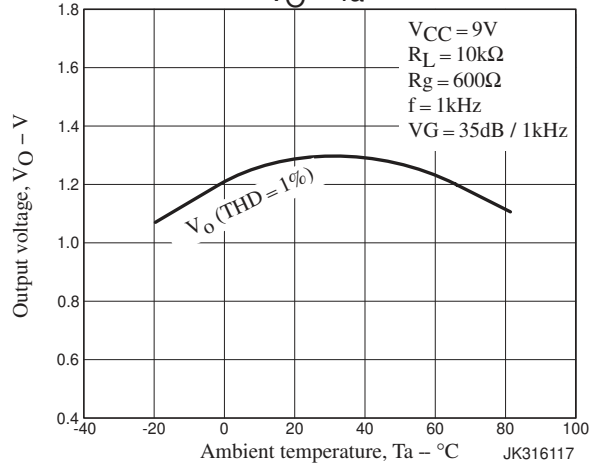
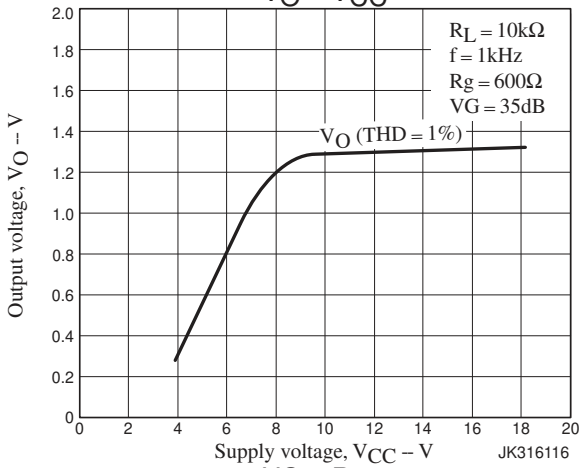
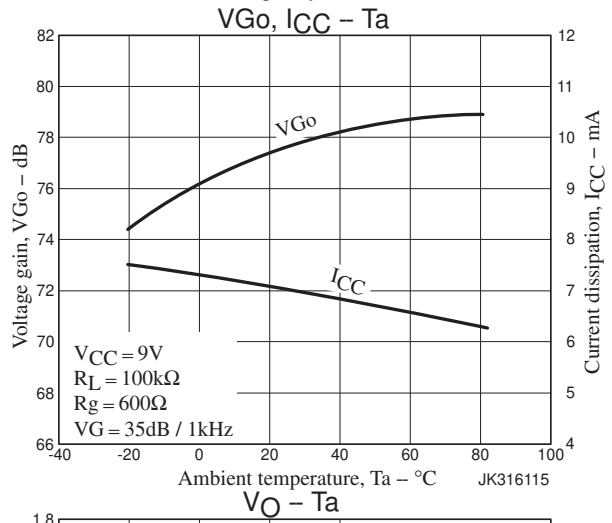
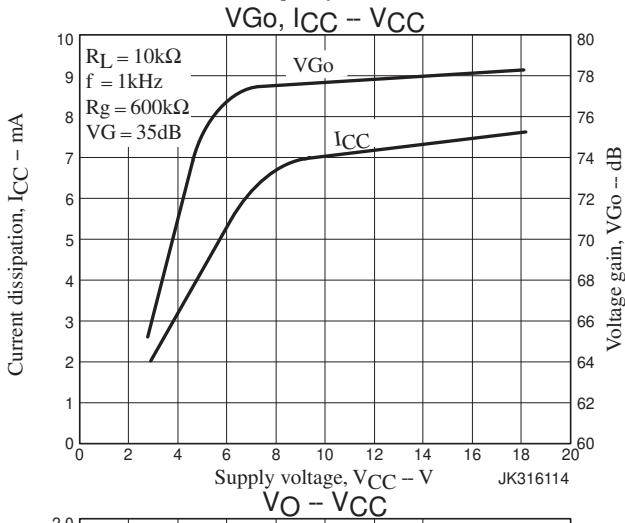
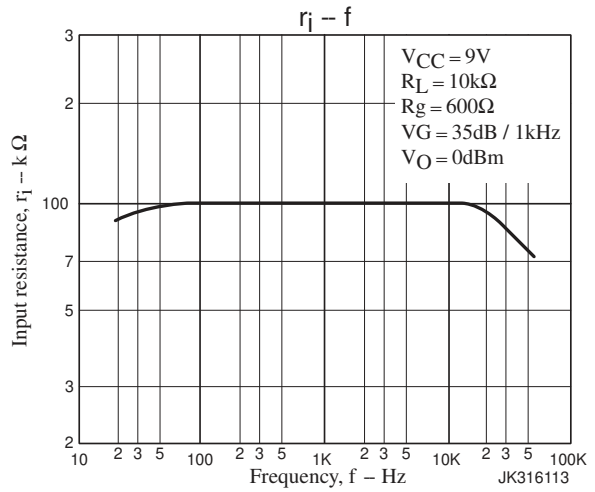
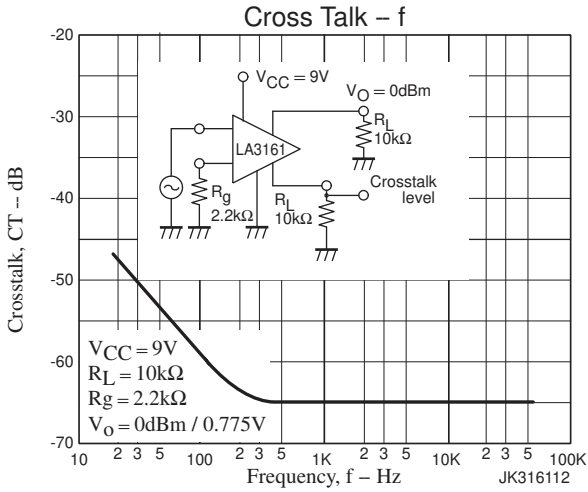

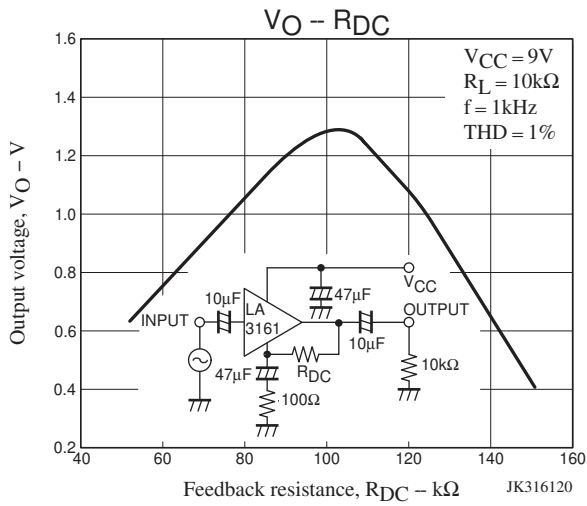

ORDERING INFORMATION

Device	Package	Shipping (Qty / Packing)
LA3161-E	SIP8 22x4.5 / SIP8 (Pb-Free)	25 / Fan-Fold

ON Semiconductor and the ON logo are registered trademarks of Semiconductor Components Industries, LLC (SCILLC) or its subsidiaries in the United States and/or other countries. SCILLC owns the rights to a number of patents, trademarks, copyrights, trade secrets, and other intellectual property. A listing of SCILLC's product/patent coverage may be accessed at www.onsemi.com/site/pdf/Patent-Marking.pdf. SCILLC reserves the right to make changes without further notice to any products herein. SCILLC makes no warranty, representation or guarantee regarding the suitability of its products for any particular purpose, nor does SCILLC assume any liability arising out of the application or use of any product or circuit, and specifically disclaims any and all liability, including without limitation special, consequential or incidental damages. "Typical" parameters which may be provided in SCILLC data sheets and/or specifications can and do vary in different applications and actual performance may vary over time. All operating parameters, including "Typicals" must be validated for each customer application by customer's technical experts. SCILLC does not convey any license under its patent rights nor the rights of others. SCILLC products are not designed, intended, or authorized for use as components in systems intended for surgical implant into the body, or other applications intended to support or sustain life, or for any other application in which the failure of the SCILLC product could create a situation where personal injury or death may occur. Should Buyer purchase or use SCILLC products for any such unintended or unauthorized application, Buyer shall indemnify and hold SCILLC and its officers, employees, subsidiaries, affiliates, and distributors harmless against all claims, costs, damages, and expenses, and reasonable attorney fees arising out of, directly or indirectly, any claim of personal injury or death associated with such unintended or unauthorized use, even if such claim alleges that SCILLC was negligent regarding the design or manufacture of the part. SCILLC is an Equal Opportunity/Affirmative Action Employer. This literature is subject to all applicable copyright laws and is not for resale in any manner.