

REVISIONS					
REV	ECO	DESCRIPTION	DATE	BY	APPR
A1	--	RELEASE NEW DRAWING	20JUN18	JONY	TOMMY
A2	--	REVISED DRAWING	10JUL20	JHEAD	DH

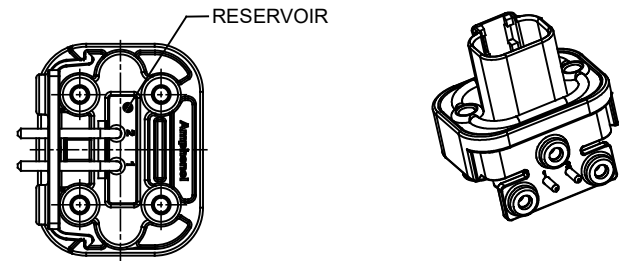

3xØ2.79±0.12  
 RECOMMENDED SCREW: 4-20 [M3.12 x 1.27]  
 THREAD-FORMING SCREW,  
 TORQUE: 6-10 IN-LB [0.68-1.13 NM]

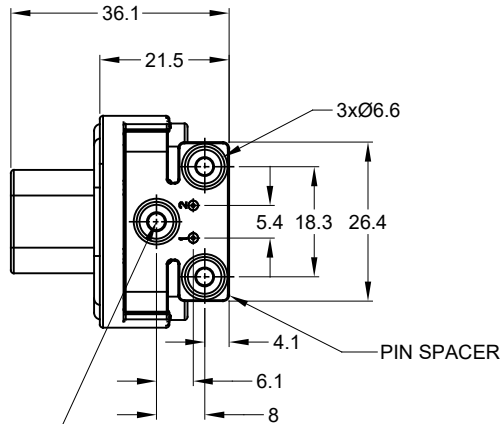
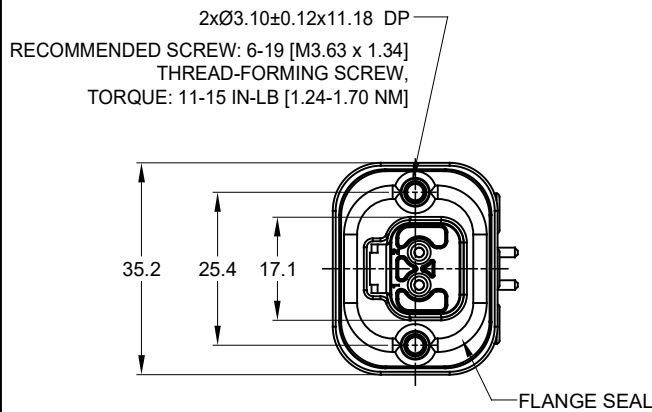
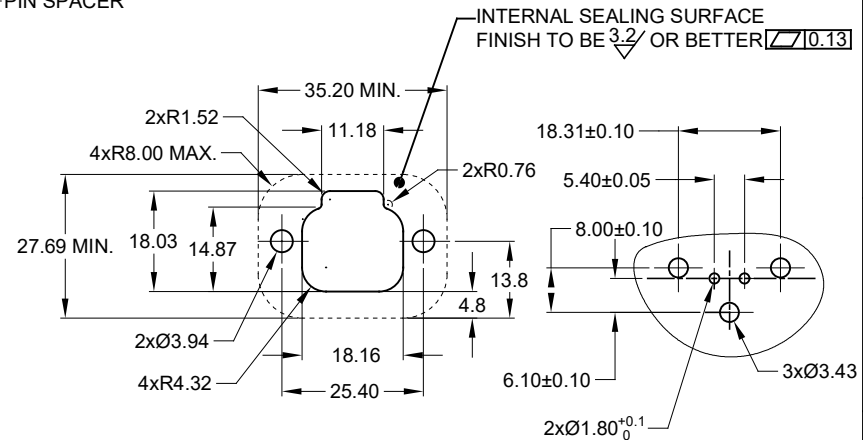
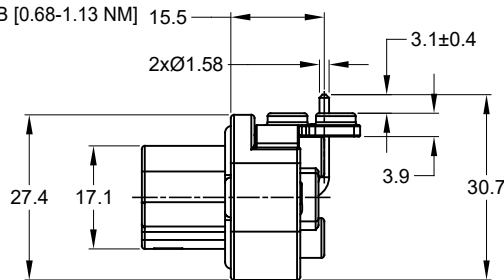

RECOMMENDED PANEL CUTOUT

RECOMMENDED PCB LAYOUT

NOTES: UNLESS OTHERWISE SPECIFIED

- MATERIAL:  
 HOUSING: THERMOPLASTIC  
 SEAL: SILICONE RUBBER  
 CONTACT: COPPER ALLOY
- MODIFICATIONS: FLANGE, PCB MOUNT RIGHT ANGLE
- SPECIFICATIONS:  
 3.1 CURRENT RATING: 13 AMPS  
 3.2 OPERATING TEMPERATURE: -55°C TO +125°C  
 3.3 DIELECTRIC WITHSTANDING VOLTAGE: LESS THAN 2 MILLIAMPS CURRENT LEAKAGE @ 1500 VOLTS AC.  
 3.4 INSULATION RESISTANCE: 1000 MEGOHMS MIN @ 25°C.  
 3.5 MOISTURE RESISTANCE: IP67 ( MATED CONDITION )  
 3.6 MATING CYCLE DURABILITY: 100 CYCLES  
 3.7 RoHS COMPLIANT
- MATING PART: AT06-2S\* PLUG  
 (\* = MODIFICATIONS)
- ALL DIMENSIONS ARE FOR REFERENCE USE ONLY.
- POTTED CONNECTORS SPECIFIED FOR UP TO 5 P.S.I. APPLICATIONS.

AT13-2P-BMXX VARIANTS		
CONTACT PLATING	POTTING OR NOT IN RESERVOIR	PART NUMBER
GOLD	NO POTTING	AT13-2P-BM01
GOLD	POTTING	AT13-2P-BM02
TIN	NO POTTING	AT13-2P-BM03
TIN	POTTING	AT13-2P-BM04

AT13-2P-BMXX		REF: DT13-2P	
QUANTITY	PART NUMBER	DESCRIPTION	ITEM
<b>MATERIALS LIST</b> UNLESS OTHERWISE SPECIFIED: 1) All dimensions are in metric (mm). 2) Tolerances are as follows: 1 PL DEC ±0.30 Fractions ±1/64 2 PL DEC ±0.15 Angles ±1° 3 PL DEC ±0.08 3) Note reference = $\Delta$			
SIGNATURES		DATE	
DRAWN: JONY XIE		20JUN18	
CHECKED: ORION LI		20JUN18	
ENGINEER:			
APPROVAL: TOMMY XIE		20JUN18	
CUSTOMER:			
MATERIAL SPECIFICATIONS:			
PROCESS SPECIFICATIONS:			
NEXT ASSY:			
THIS DRAWING IS SUPPLIED FOR INFORMATION ONLY. DESIGN FEATURES, SPECIFICATIONS AND PERFORMANCE DATA SHOWN HEREON ARE THE PROPERTY OF THE AMPHENOL CORPORATION. NO RIGHTS OF REPRODUCTION ARE IMPLIED. ALL DIMENSIONS ARE SUBJECT TO NORMAL MANUFACTURING VARIATIONS.		SIZE: B C-	DWG NO: AT13-2P-BMXX
SCALE: NONE		REVISION: A2	
SHEET 1 OF 1			

TITLE: BOARDLOCK PCB MOUNT RECEPT, 2PIN, RA FLANGE, AT SERIES DWG NO: AT13-2P-BMXX REV: A2 SH: 1 OF: 1