

PART NUMBER	REVISION	DESCRIPTION	FEED TYPE
2266473-1	B	FINE CRIMP HEIGHT ADJUST	MECHANICAL
2266473-2	C	FINE CRIMP HEIGHT ADJUST	PNEUMATIC
7-2266473-1	B	MECHANICAL AND CRIMP TOOLING KIT	MECHANICAL
7-2266473-2	C	PNEUMATIC AND CRIMP TOOLING KIT	PNEUMATIC
7-2266473-7	A	CRIMP TOOLING KIT	-

ATLANTIC VERSION TERMINATOR INTERFACE ADAPTER

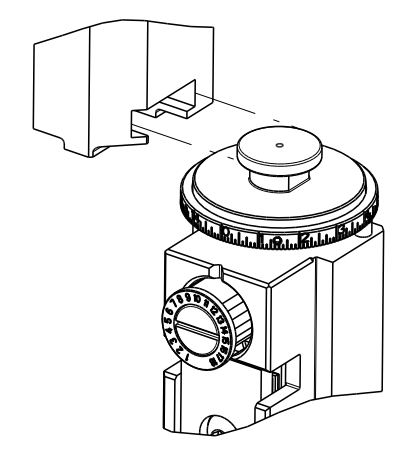

APPLICATOR DATA		
CRIMP	SIZE	TYPE
WIRE	1.58 mm [.062]	F
INSUL	2.15 mm [.085]	F

APPLICATOR INSTRUCTIONS  
408-35042

TERMINAL DATA: SUMITOMO TERMINAL SUMITOMO CRIMP SPECIFICATION			
TERMINAL NAME: US 1.5mm UNSEALED FEMALE TERMINAL			
WIRE STRIP LENGTH		INSULATION DIAMETER RANGE	
3.60-4.40 mm [.142-.173 IN]		Ø1.35-1.80 mm [.053-.071 IN]	
TERMINAL APPLICATION SPECIFICATION	SUMITOMO SPEC		
TERMINALS APPLIED			
TE TERMINAL	SUMITOMO TERMINAL	TE TERMINAL	SUMITOMO TERMINAL
1949952-1	8240-0123	1949952-2	8240-0127

WIRE SIZE	CRIMP HEIGHT mm [INCH]	CRIMP HEIGHT REFERENCE SETTING
0.50mm2	1.20 +/- 0.05 [1.047 +/- .002]	6.3
0.35mm2	1.10 +/- 0.05 [1.043 +/- .002]	7.3

- 1 RECOMMENDED SPARE PARTS
- 2 REFER TO SUPPLIED INSTRUCTION SHEET FOR CLEANING, LUBRICATION AND STORAGE OF APPLICATOR.
- 3 APPLY PART NUMBER 2-23419-6 LOCTITE TO THREADS OF ITEM 242.
- 4 CRIMP HEIGHT REFERENCE SETTING WAS THE SETTING USED WHEN THE APPLICATOR WAS QUALIFIED AT THE FACTORY. ADJUSTMENT MAY BE NECESSARY WHEN RUNNING APPLICATOR IN THE FIELD.
- 5. UNLESS SPECIFIED OTHERWISE TORQUE VALUES SHALL BE USED PER DOCUMENT, 101-35000.
- 6 TERMINAL LUBRICANT IS RECOMMENDED.

**\*WARNING**  
ON INSTALLATION, SET WIRE DISC TO CRIMP HEIGHT REFERENCE SETTING FOR LARGEST WIRE SIZE. CRIMP HEIGHT REFERENCE SETTINGS GREATER THAN THE VALUE SHOWN MAY CAUSE DAMAGE TO THE CRIMP TOOLING, REFER TO THE INSTRUCTION SHEET FOR PROPER SETUP AND ADJUSTMENTS.

LOC	DIST	REVISIONS					
A	66	P	LTN	DESCRIPTION	DATE	OWN	APVD
		1		DEVELOPMENT	28AUG2014	XZ	TE
		A		RELEASED	14OCT2014	JH	TE
		B		ECR-19-005013	28MAR2019	FL	CT
		C		ECR-19-010597	06JUL2019	TB	TE

-	1	-	1	-	2119641-1	FEED CAM, AIR FEED	248	
-	1	1	1	1	2119082-5	CAM, SNAIL, INSULATION ADJUSTMENT	244	
-	1	1	1	1	2079764-1	WASHER, WAVE SPRING, CREST-TO-CREST	243	
-	1	1	1	1	2119083-1	RETAINER, INSULATION DIAL	242	
-	1	1	1	1	7-18023-7	SCR, SKT HD CAP M3 X 4.0	241	
-	-	1	-	1	2119580-1	MECHANICAL FEED ASSEMBLY	239	
-	1	-	1	-	2844940-1	AIR FEED MODULE	238	
-	REF	REF	REF	REF	994970-2	COUNTER, MAGNETIC	164	
-	1	1	1	1	2119955-1	ASSY, LUBRICATOR, SIDE FEED	113	
-	1	1	1	1	2844908-1	SCREW, LOCKING	99	
-	1	1	1	1	2844907-1	POST, LOCKING	98	
-	1	1	1	1	455888-5	SPACER, CRIMPER	82	
-	1	1	1	1	5-547505-2	SPRING, COMPRESSION	77	
-	1	1	1	1	854769-4	HOLDER, INS	74	
-	1	1	1	1	1803607-3	DOCUMENTATION PACKAGE	71	
-	1	1	1	1	2119740-1	TAG, IDENTIFICATION	67	
-	2	2	2	2	2168078-1	SCREW, DRIVE, RH, RoHS, 2 x .188	66	
-	1	1	1	1	2168083-2	SCR, SKT HD CAP, RoHS, M4 X 8.0	60	
-	1	1	1	1	5-18022-5	SCR, HEX HD CAP, M4 X 6.0	59	
-	1	1	1	1	21028-2	PIN, SLOTTED SPRING .062 X .250	58	
-	1	1	1	1	1338685-1	PAWL, FEED	56	
-	4	4	4	4	2168083-3	SCR, SKT HD CAP, RoHS, M4 X 12.0	54	
-	2	2	2	2	2168083-8	SCR, SKT HD CAP, RoHS, M4 X 16	53	
-	1	1	1	1	5018030-1	NUT, HEX, REG, RoHS, M3	52	
-	1	1	1	1	811242-5	BUMPER, HOLD DOWN	51	
-	1	1	1	1	690753-2	SPACER, TONKER	50	
-	1	2	1	2	18023-9	SCR, SKT HD CAP M4 X 6.0	49	
-	-	1	-	1	2119652-1	FEED CAM, PRE FEED	48	
-	-	1	-	1	2119653-1	FEED CAM, POST FEED	47	
-	1	1	1	1	1803583-9	APPLICATOR BASIC ASSEMBLY, SF	46	
-	1	1	1	1	1803515-1	RAM ASSEMBLY, SF ATLANTIC	44	
-	1	1	1	1	1803602-1	SCR, BHSC, RoHS (M8 X 25)	41	
-	1	1	1	1	1752356-3	SUPPORT, TERMINAL	34	
-	2	2	2	2	2079383-5	SCR, BHSC, RoHS (M4 X 20)	33	
-	2	2	2	2	2-2844962-6	SPACER, CYLINDRICAL, STRIP GUIDE	30	
-	1	1	1	1	2844992-1	ASSEMBLY, STRIP GUIDE	29	
-	1	1	1	1	455888-3	SPACER, CRIMPER	28	
-	1	1	1	1	1320928-2	STRIP GUIDE	24	
-	1	1	1	1	2168083-2	SCR, SKT HD CAP, RoHS, M4 X 8.0	21	
-	2	2	2	2	1-18028-2	WASHER, FLAT, REG M4	20	
-	1	1	1	1	2119533-1	STRIPPER, SIDE FEED	19	
-	1	1	1	1	2119806-1	INSERT, SHEAR	13	
-	1	1	1	1	3-22280-3	SPRING, COMPRESSION	12	
-	1	1	1	1	1-356885-4	STOP, SHEAR	11	
-	1	1	1	1	2119805-1	SHEAR HOLDER, FRONT	10	
-	1	1	1	1	1803095-6	FLOATING SHEAR, FRONT	9	
-	1	2	2	1	1803171-9	ANVIL, COMBINATION	8	
-	1	1	1	1	8-240641-8	SPACER	7	
-	-	-	-	-	-	-	6	
-	1	1	1	1	2119780-9	DEPRESSOR, SHEAR	5	
-	1	1	1	1	1-238011-7	BLOCK, CRIMPER SPACER	4	
-	1	2	2	1	5-1803017-0	CRIMPER, INSULATION F	3	
-	1	1	1	1	455888-5	SPACER, CRIMPER	2	
-	1	2	2	1	3-456403-8	CRIMPER, WIRE PREMIUM	1	
-	77	-72	-71	-2	-1	PART NO	DESCRIPTION	ITEM NO

ATLANTIC VERSION  
Shown on sheets 1 of 4 & 2 of 4  
(Pacific version shown on sheets 3 of 4 & 4 of 4)

DIMENSIONS:		TOLERANCES UNLESS OTHERWISE SPECIFIED:		MATERIAL:		FINISH:	
mm	0 PLC ±	1 PLC ±	2 PLC ±	3 PLC ±	4 PLC ±	ANGLES ±	FINISH ±

OWN	X. ZHAO	28AUG2014	TE Connectivity
CHK	L. ZHANG	28AUG2014	Harrisburg, PA 17105-3608
APVD	T. ELBIN	28AUG2014	
NAME	Ocean Side Feed Applicator		
SIZE	CAGE CODE	DRAWING NO	RESTRICTED TO
A1	00779	2266473	
Customer Accessible Production Drawing		SCALE	1:2
SHEET		1	OF 4
REV		C	

LOC		DIST		REVISIONS			
A	66	P	LYN	DESCRIPTION	DATE	DWN	APVD
		-		SEE SHEET 1			

# FEED TYPE MECHANICAL

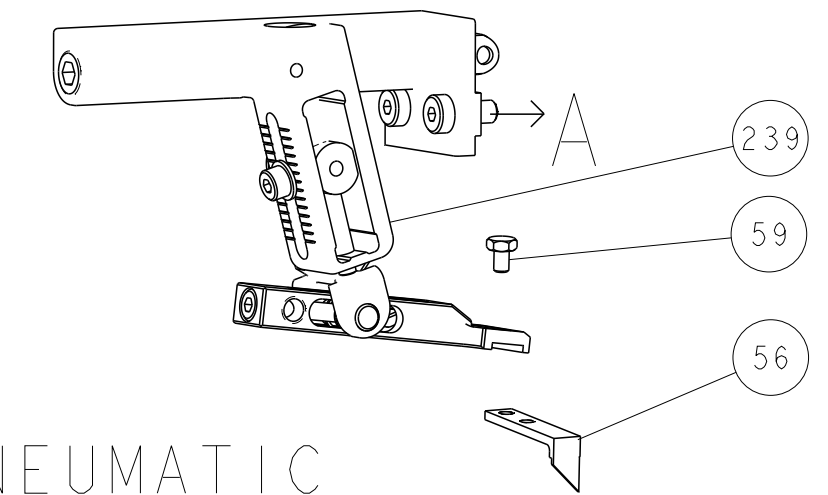

## PNEUMATIC

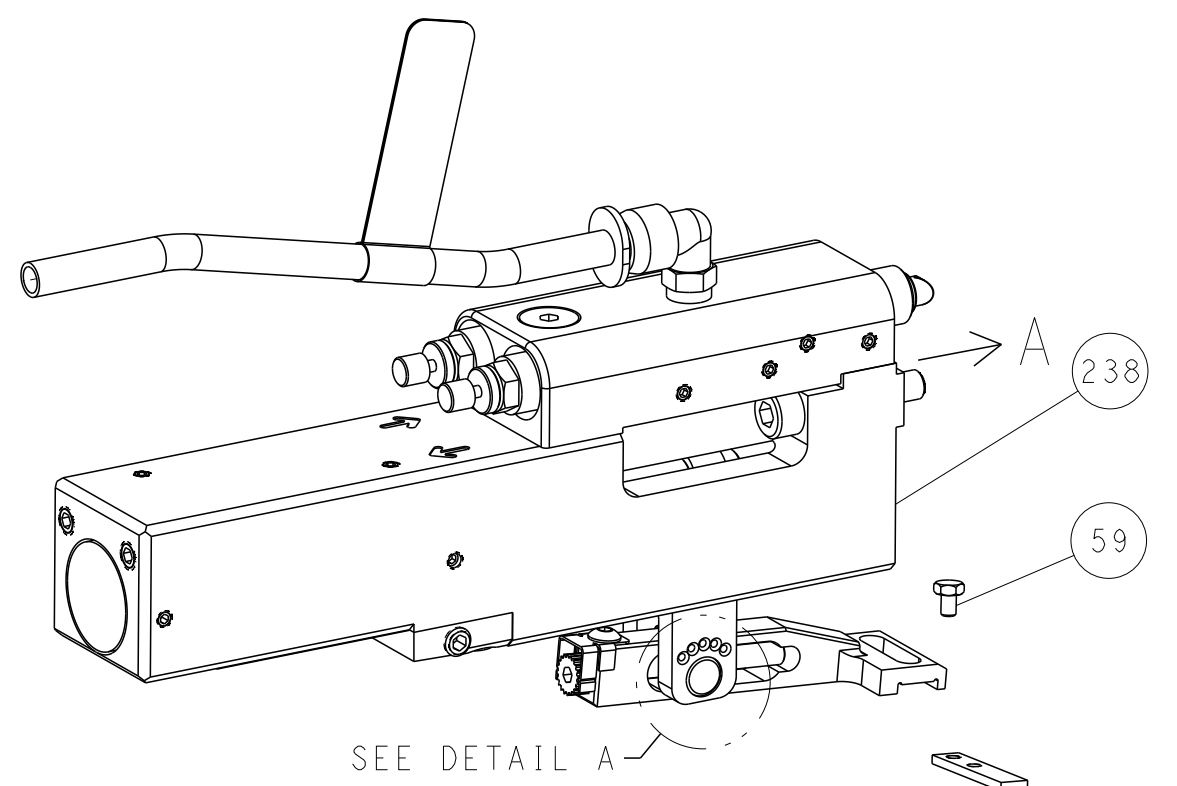

FEED SPRING SETTING POSITION (SHOWN FROM REAR SIDE)

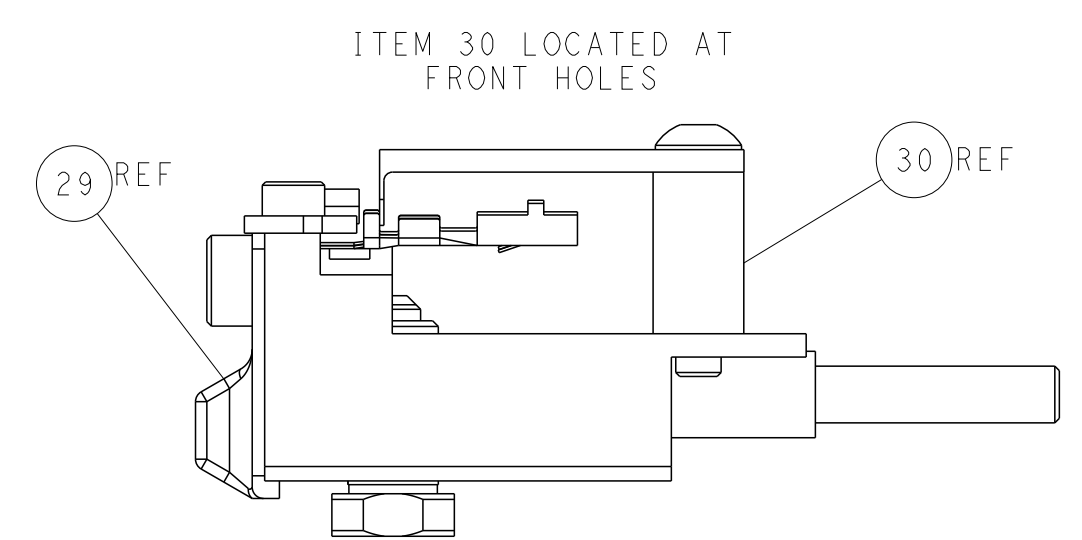
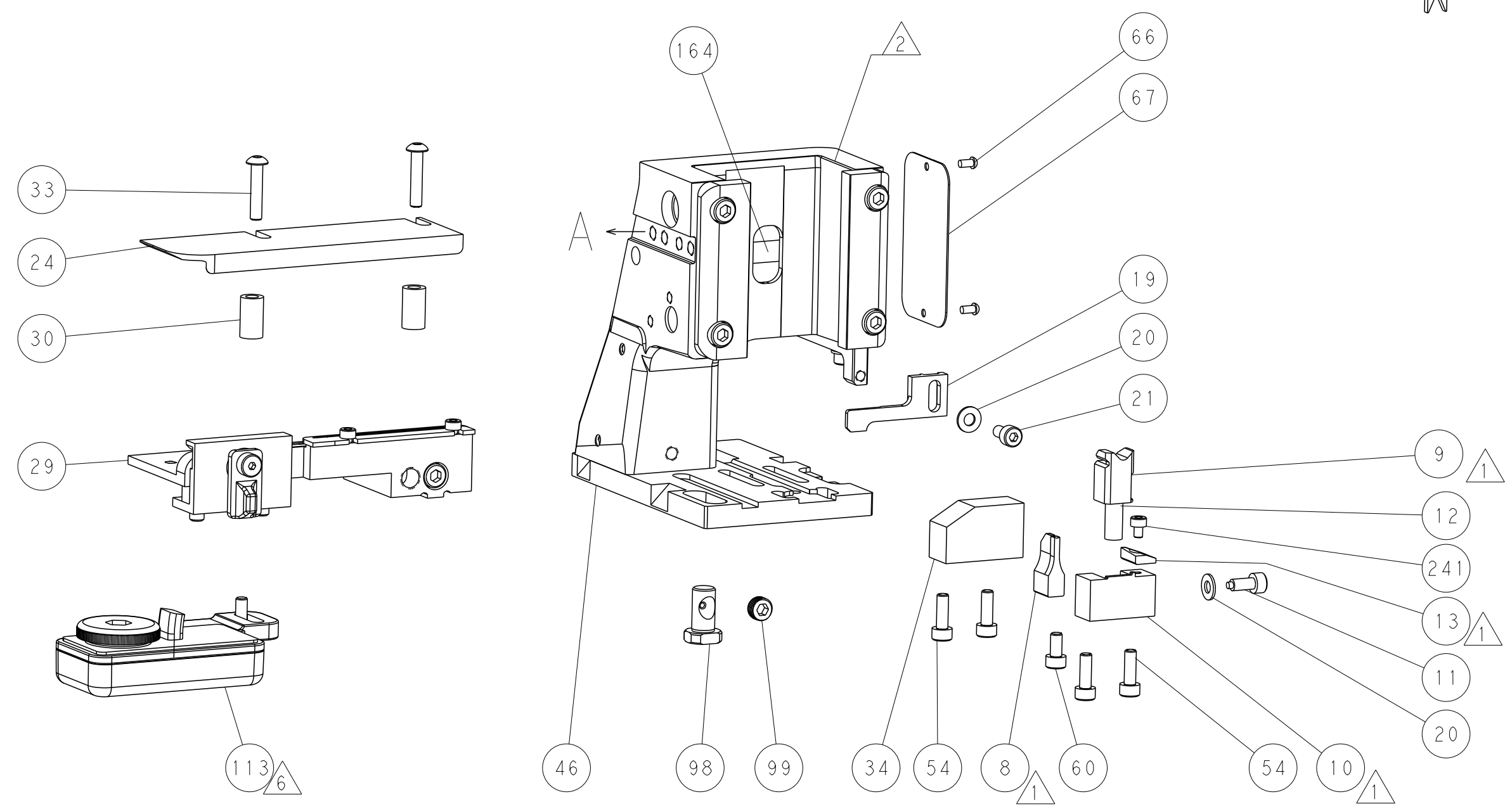
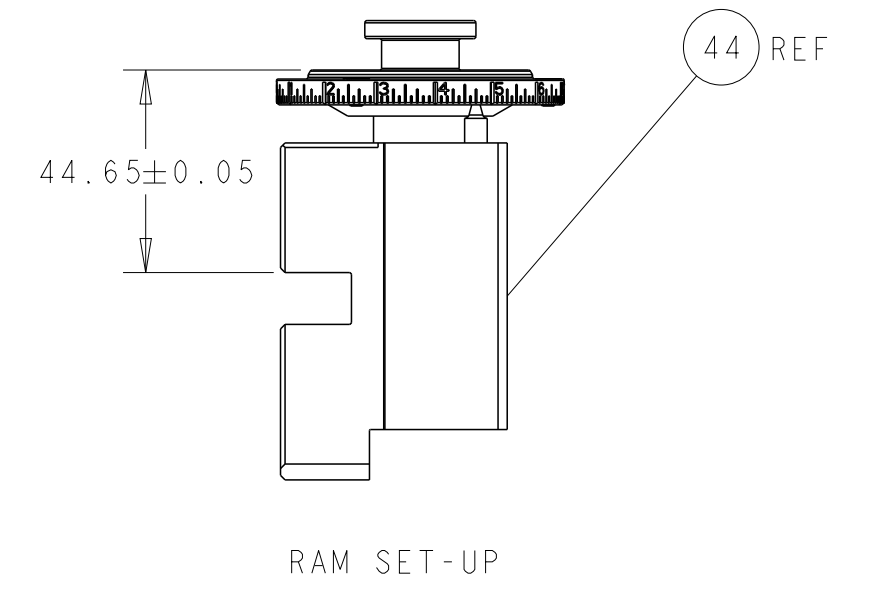
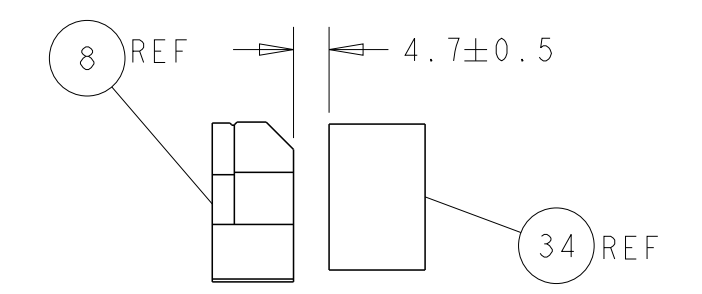
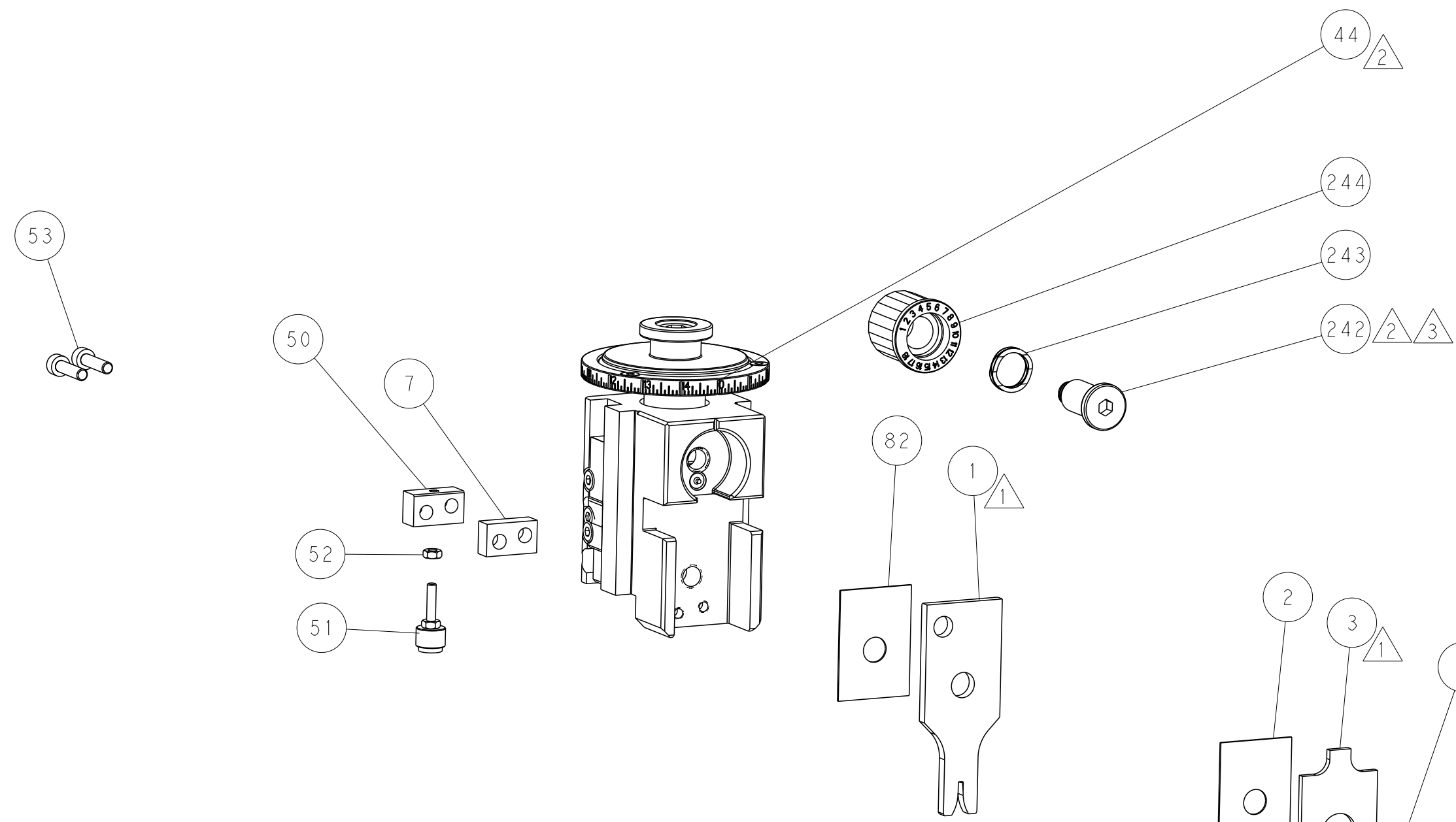
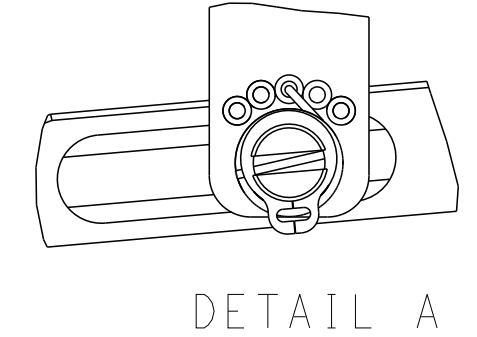

## CAM POSITIONS

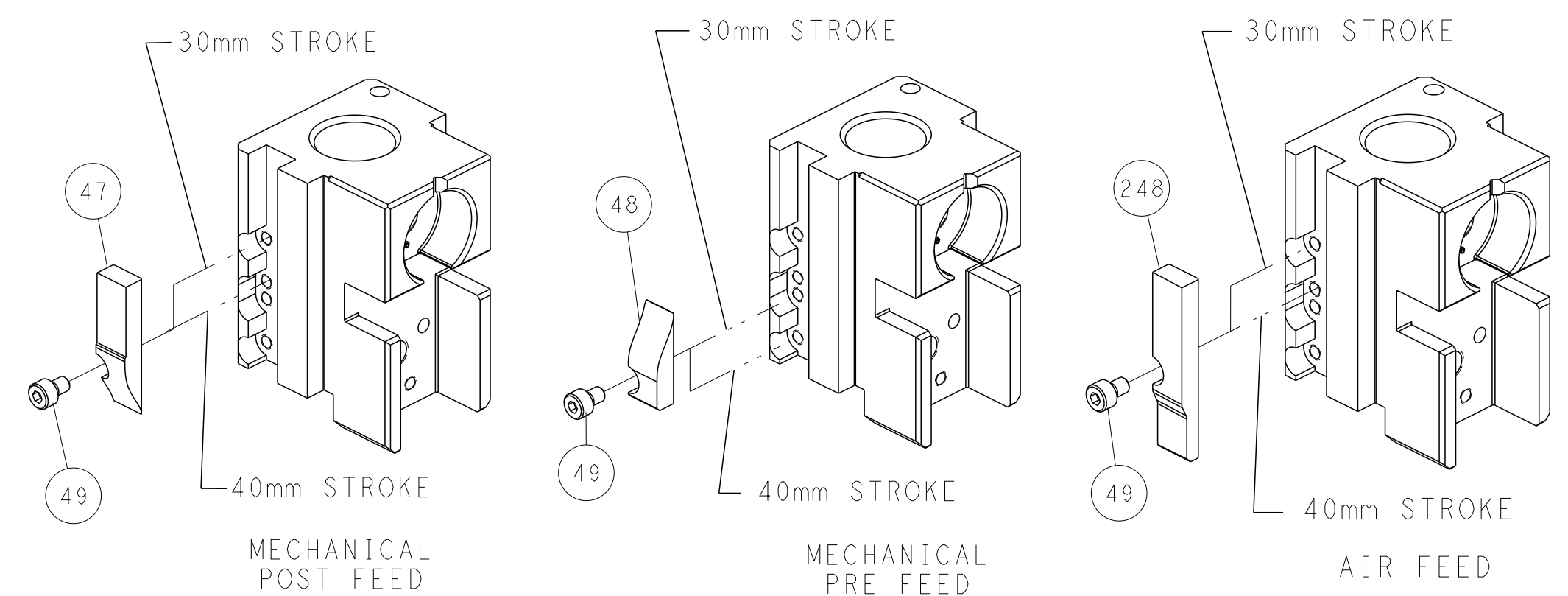

**ATLANTIC VERSION**  
 Shown on sheets 1 of 4 & 2 of 4  
 (Pacific version shown on sheets 3 of 4 & 4 of 4)

DIMENSIONS:		TOLERANCES UNLESS OTHERWISE SPECIFIED:		DWN X.ZHAO 28AUG2014		TE Connectivity	
mm	0 PLC ±	1 PLC ±	2 PLC ±	3 PLC ±	4 PLC ±	Harrisburg, PA 17105-3608	
MATERIAL:		FINISH:		CHK L.ZHANG 28AUG2014		NAME	
				APVD T.ELBIN 28AUG2014		Ocean Side Feed Applicator	
				PRODUCT SPEC		SIZE CAGE CODE DRAWING NO	
				APPLICATION SPEC		RESTRICTED TO	
				WEIGHT		A1 00779 C=2266473	
				Customer Accessible Production Drawing		SCALE 1:2 SHEET 2 OF 4 REV C	

PART NUMBER	REVISION	DESCRIPTION	FEED TYPE
2-2266473-1	B	FINE CRIMP HEIGHT ADJUST	MECHANICAL
2-2266473-2	C	FINE CRIMP HEIGHT ADJUST	PNEUMATIC
7-2266473-7	A	CRIMP TOOLING KIT	-

PACIFIC VERSION TERMINATOR  
INTERFACE ADAPTER

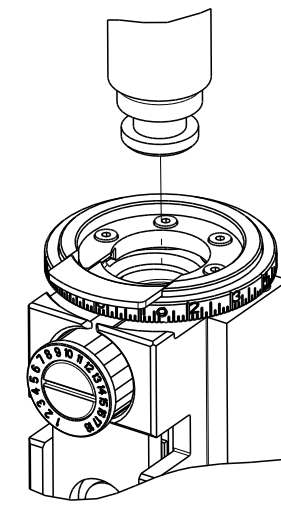

APPLICATOR DATA		
CRIMP	SIZE	TYPE
WIRE	1.58 mm [.062]	F
INSUL	2.15 mm [.085]	F
APPLICATOR INSTRUCTIONS 408-35042		

TERMINAL DATA: SUMITOMO TERMINASUMITOMO CRIMP SPECIFICATION			
TERMINAL NAME: US 1.5mm UNSEALED FEMALE TERMINAL			
WIRE STRIP LENGTH		INSULATION DIAMETER RANGE	
3.60-4.40 mm [.142-.173 IN]		∅1.35-1.80 mm [.053-.071 IN]	
TERMINAL APPLICATION SPECIFICATION	SUMITOMO SPEC	-	-
TERMINALS APPLIED <sup>6</sup>			
TE TERMINAL	SUMITOMO TERMINAL	TE TERMINAL	SUMITOMO TERMINAL
1949952-1	8240-0123	1949952-2	8240-0127

WIRE SIZE	CRIMP HEIGHT mm [INCH]	CRIMP HEIGHT REFERENCE SETTING
0.50mm2	1.20 +/- 0.05 [.047 +/- .002]	6.3
0.35mm2	1.10 +/- 0.05 [.043 +/- .002]	7.3

- <sup>1</sup> RECOMMENDED SPARE PARTS
- <sup>2</sup> REFER TO SUPPLIED INSTRUCTION SHEET FOR CLEANING, LUBRICATION AND STORAGE OF APPLICATOR.
- <sup>3</sup> APPLY PART NUMBER 2-23419-6 LOCTITE TO THREADS OF ITEM 242.
- <sup>4</sup> CRIMP HEIGHT REFERENCE SETTING WAS THE SETTING USED WHEN THE APPLICATOR WAS QUALIFIED AT THE FACTORY. ADJUSTMENT MAY BE NECESSARY WHEN RUNNING APPLICATOR IN THE FIELD.
- 5. UNLESS SPECIFIED OTHERWISE TORQUE VALUES SHALL BE USED PER DOCUMENT, 101-35000.
- <sup>6</sup> TERMINAL LUBRICANT IS RECOMMENDED.

**\*WARNING**  
ON INSTALLATION, SET WIRE DISC TO CRIMP HEIGHT REFERENCE SETTING FOR LARGEST WIRE SIZE. CRIMP HEIGHT REFERENCE SETTINGS GREATER THAN THE VALUE SHOWN MAY CAUSE DAMAGE TO THE CRIMP TOOLING, REFER TO THE INSTRUCTION SHEET FOR PROPER SETUP AND ADJUSTMENTS.

LOC	DIST	REVISIONS					
A	66	P	LTN	DESCRIPTION	DATE	DWN	APVD
		-		SEE SHEET 1	-	-	-

-	1	1	2119082-5	CAM, SNAIL, INSULATION ADJUSTMENT	244
-	1	1	2079764-1	WASHER, WAVE SPRING, CREST-TO-CREST	243
-	1	1	2119083-1	RETAINER, INSULATION DIAL	242
-	1	1	7-18023-7	SCR, SKT HD CAP M3 X 4.0	241
-	-	1	2119580-1	MECHANICAL FEED ASSEMBLY	239
-	1	-	2844940-1	AIR FEED MODULE	238
-	REF	REF	994970-2	COUNTER, MAGNETIC	164
-	1	-	2119641-2	FEED CAM, AIR FEED	151
-	1	1	2168083-8	SCR, SKT HD CAP, RoHS, M4 X 16	144
-	4	4	2168083-9	SCR, SKT HD CAP, RoHS, M4 X 20	143
-	-	1	2119653-2	FEED CAM, POST FEED	142
-	1	1	1-1803583-0	APPLICATOR BASIC ASSEMBLY, SF	141
-	1	1	1803516-1	RAM ASSEMBLY, SF PACIFIC	140
-	1	1	2119955-1	ASSY, LUBRICATOR, SIDE FEED	113
-	1	1	2844908-1	SCREW, LOCKING	99
-	1	1	2844907-1	POST, LOCKING	98
-	1	1	455888-5	SPACER, CRIMPER	82
-	1	1	5-547505-2	SPRING, COMPRESSION	77
-	1	1	854769-4	HOLDER, INS	74
-	1	1	1803607-3	DOCUMENTATION PACKAGE	71
-	1	1	2119740-1	TAG, IDENTIFICATION	67
-	2	2	2168078-1	SCREW, DRIVE, RH, RoHS, 2 x .188	66
-	1	1	5-18022-5	SCR, HEX HD CAP, M4 X 6.0	59
-	1	1	21028-2	PIN, SLOTTED SPRING .062 X .250	58
-	1	1	1338685-1	PAWL, FEED	56
-	2	2	2168083-8	SCR, SKT HD CAP, RoHS, M4 X 16	53
-	1	1	5018030-1	NUT, HEX, REG, RoHS, M3	52
-	1	1	811242-5	BUMPER, HOLD DOWN	51
-	1	1	690753-2	SPACER, TONKER	50
-	1	2	18023-9	SCR, SKT HD CAP M4 X 6.0	49
-	-	1	2119652-1	FEED CAM, PRE FEED	48
-	1	1	1803602-1	SCR, BHSC, RoHS (M8 X 25)	41
-	1	1	1752356-3	SUPPORT, TERMINAL	34
-	2	2	2079383-5	SCR, BHSC, RoHS (M4 X 20)	33
-	2	2	2-2844962-6	SPACER, CYLINDRICAL, STRIP GUIDE	30
-	1	1	2844992-1	ASSEMBLY, STRIP GUIDE	29
-	1	1	455888-3	SPACER, CRIMPER	28
-	1	1	1320928-2	STRIP GUIDE	24
-	1	1	2168083-2	SCR, SKT HD CAP, RoHS, M4 X 8.0	21
-	2	2	1-18028-2	WASHER, FLAT, REG M4	20
-	1	1	2119533-1	STRIPPER, SIDE FEED	19
-	1	1	2119806-1	INSERT, SHEAR	13
-	1	1	3-22280-3	SPRING, COMPRESSION	12
-	1	1	1-356885-4	STOP, SHEAR	11
-	1	1	2119805-1	SHEAR HOLDER, FRONT	10
-	1	1	1803095-6	FLOATING SHEAR, FRONT	9
-	1	1	1803171-9	ANVIL, COMBINATION	8
-	1	1	8-240641-8	SPACER	7
-	-	-	-	-	6
-	1	1	2119780-9	DEPRESSOR, SHEAR	5
-	1	1	1-238011-7	BLOCK, CRIMPER SPACER	4
-	1	1	5-1803017-0	CRIMPER, INSULATION F	3
-	1	1	455888-5	SPACER, CRIMPER	2
-	1	1	3-456403-8	CRIMPER, WIRE PREMIUM	1

PACIFIC VERSION  
Shown on sheets 3 of 4 & 4 of 4  
(Atlantic version shown on sheets 1 of 4 & 2 of 4)

DIMENSIONS: mm		TOLERANCES UNLESS OTHERWISE SPECIFIED:		DWN X.ZHAO 28AUG2014		CHK L.ZHANG 28AUG2014		APVD T.ELBIN 28AUG2014		NAME	
0 PLC	±	1 PLC	±	TE Connectivity		Harrisburg, PA 17105-3608		PRODUCT SPEC		Ocean Side Feed Applicator	
2 PLC	±	3 PLC	±	SIZE		CAGE CODE		DRAWING NO		RESTRICTED TO	
4 PLC	±	5 PLC	±	A1		00779		C=2266473		-	
ANGLES	±	FINISH	±	Customer Accessible Production Drawing		SCALE		1:2		SHEET 3 OF 4	
MATERIAL		FINISH		WEIGHT		SCALE		1:2		REV C	

LOC	DIST	REVISIONS					
A	66	P	LTN	DESCRIPTION	DATE	DWN	APVD
		-		SEE SHEET 1			

# FEED TYPE MECHANICAL

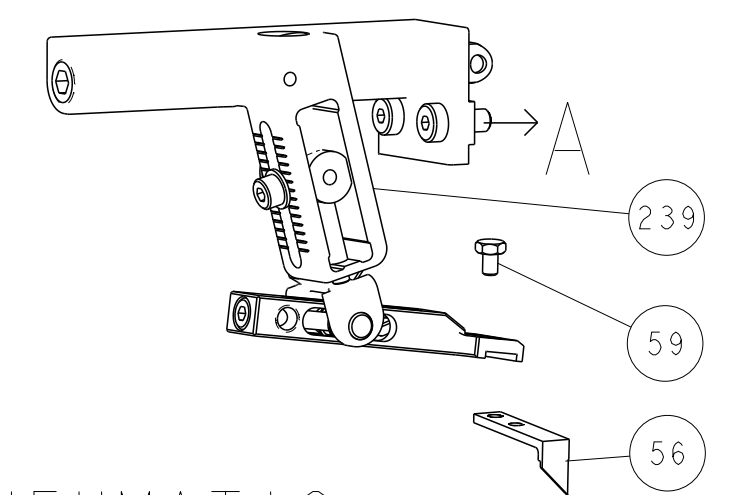

## PNEUMATIC

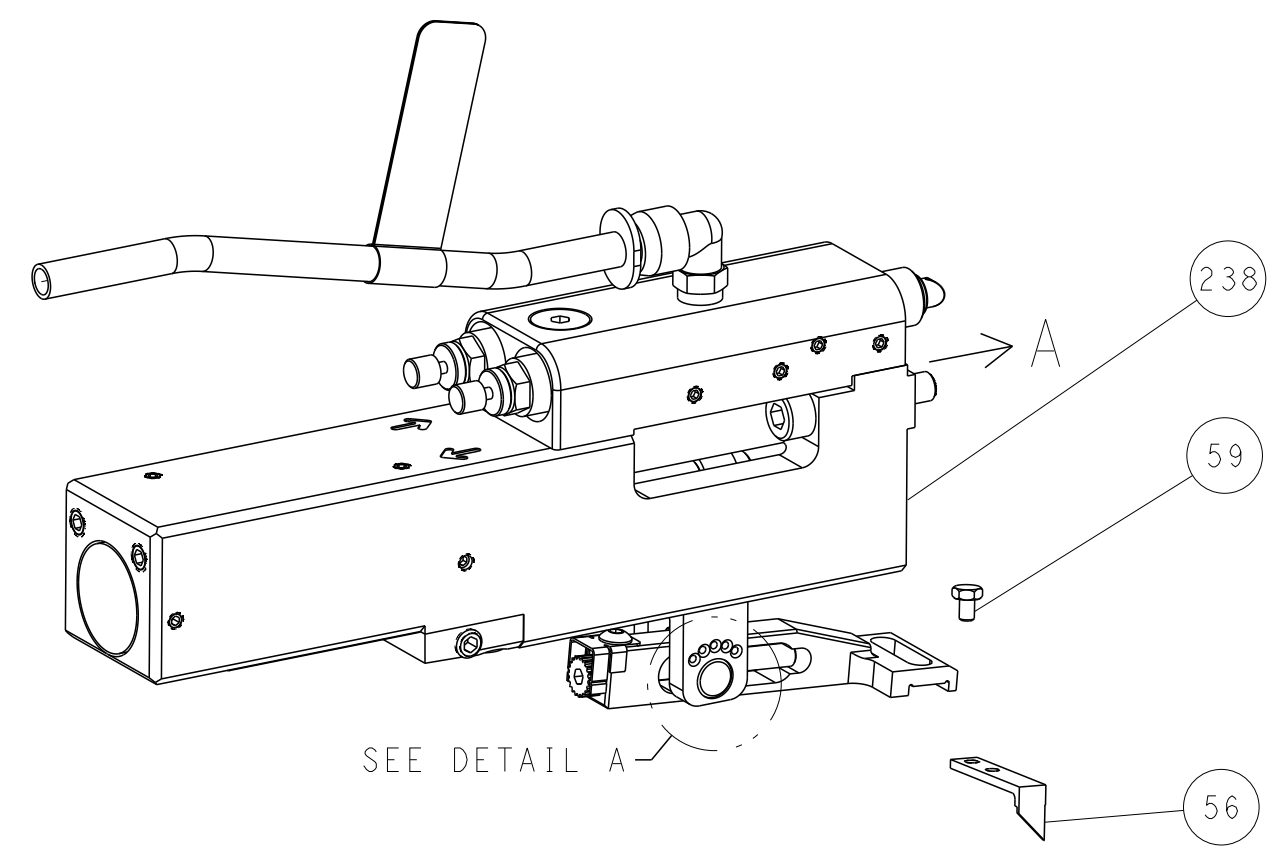

### FEED SPRING SETTING POSITION (SHOWN FROM REAR SIDE)

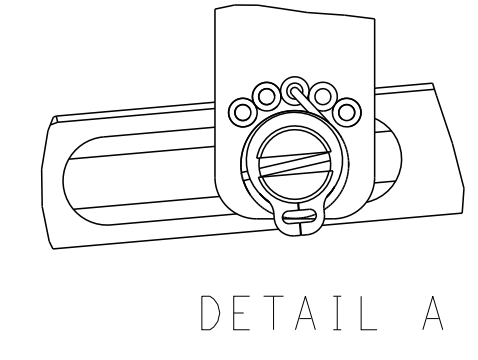

DETAIL A

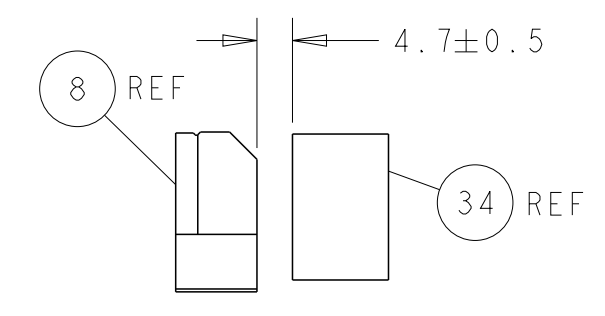
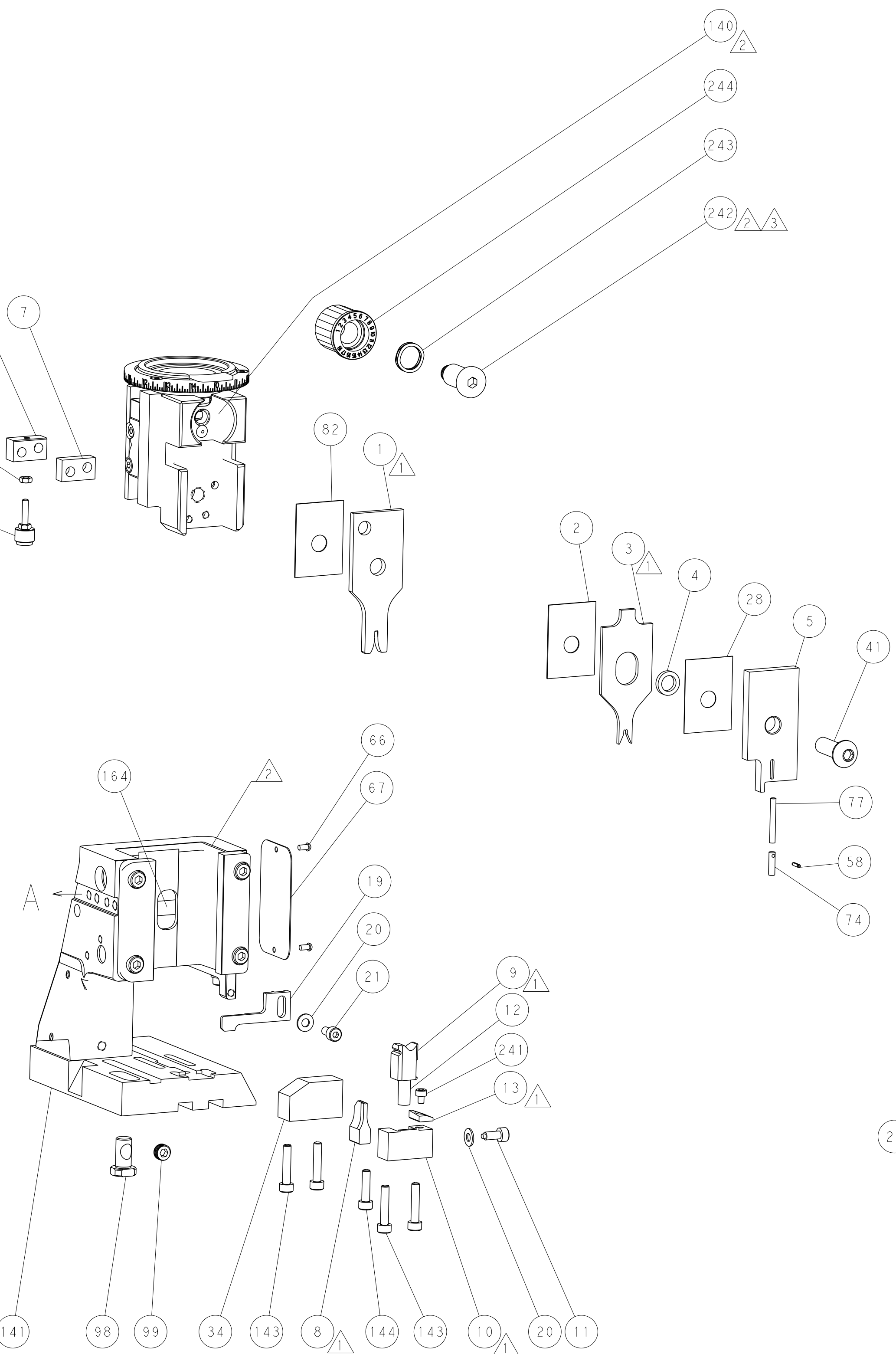
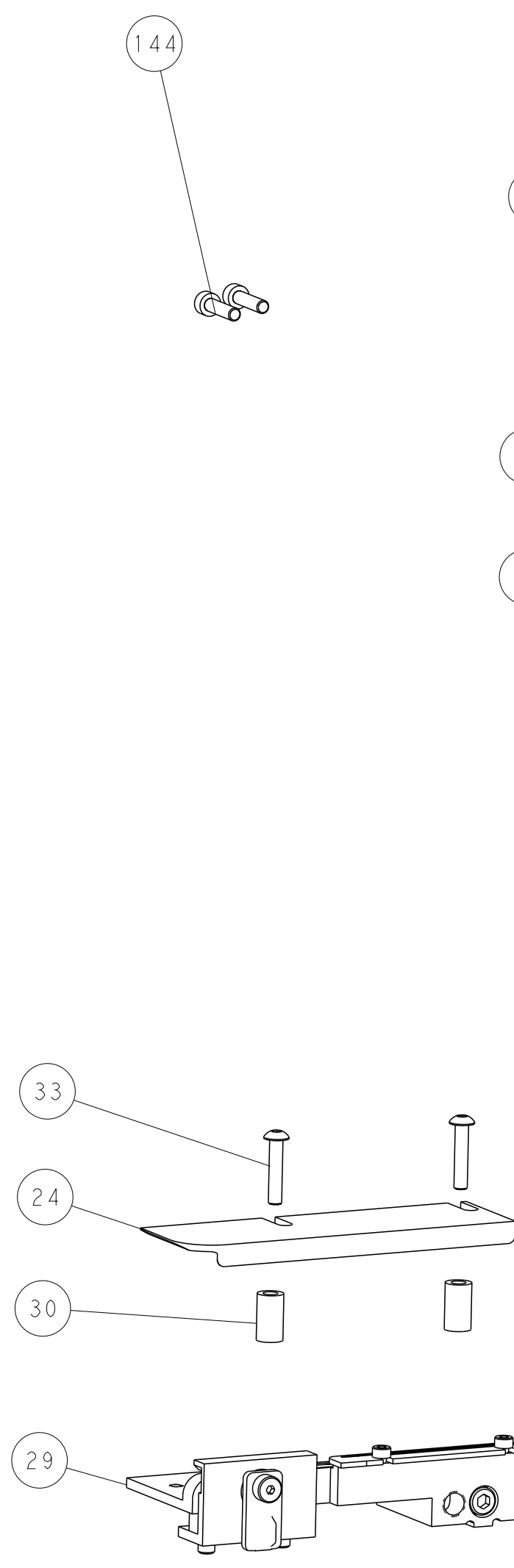

TERMINAL SUPPORT LOCATION

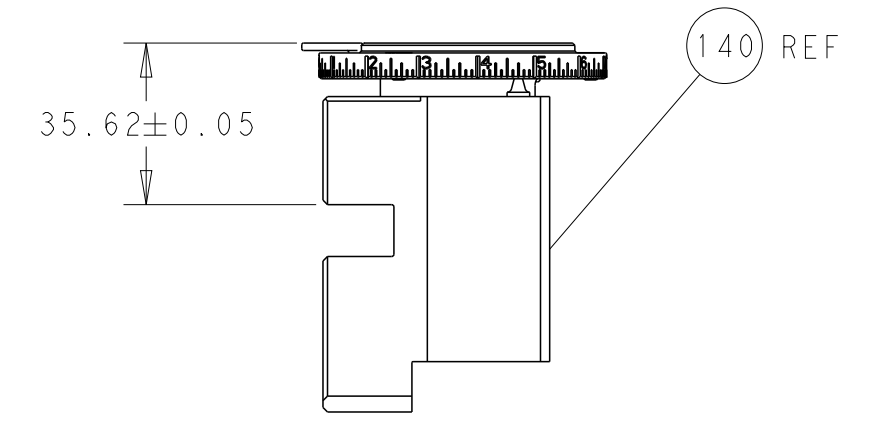

RAM SET-UP

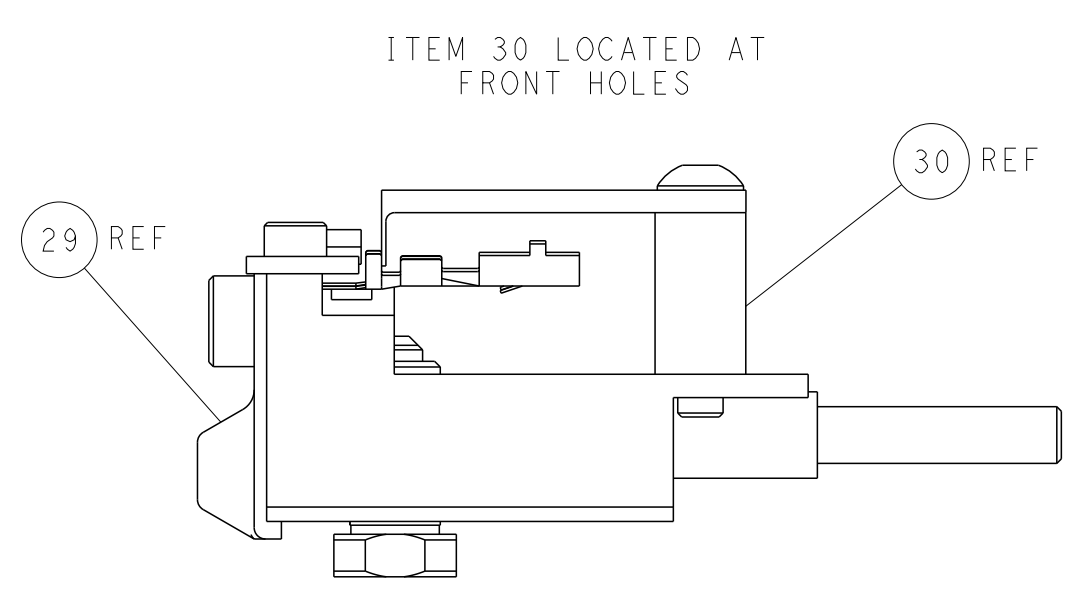

FEED TRACK POSITION GUIDE BY INSULATION BARREL

## CAM POSITIONS

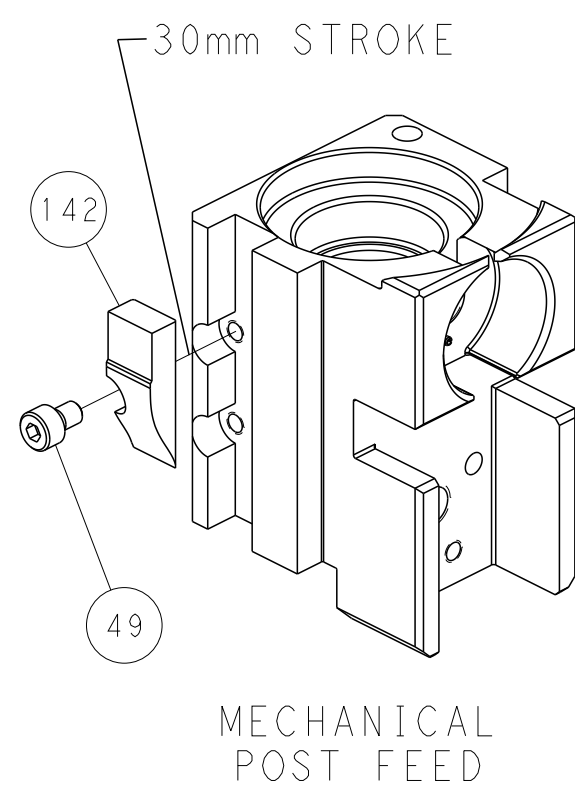

MECHANICAL POST FEED

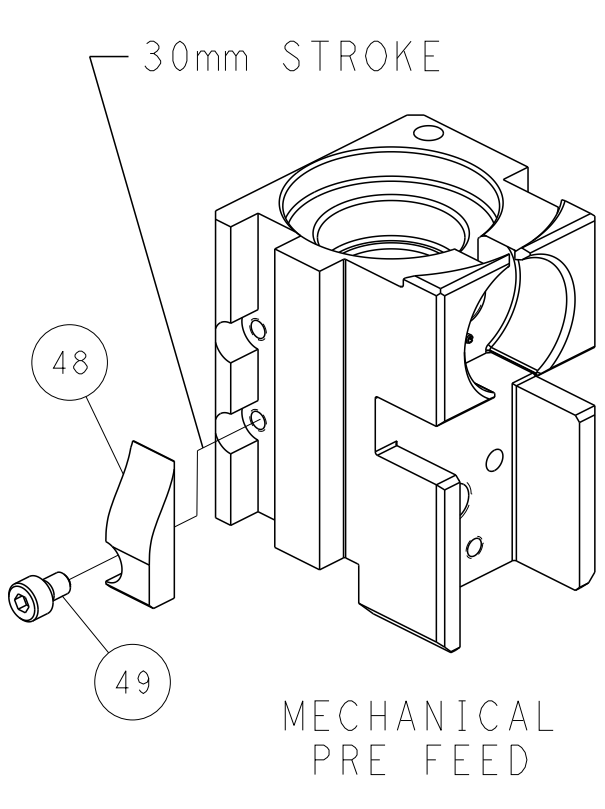

MECHANICAL PRE FEED

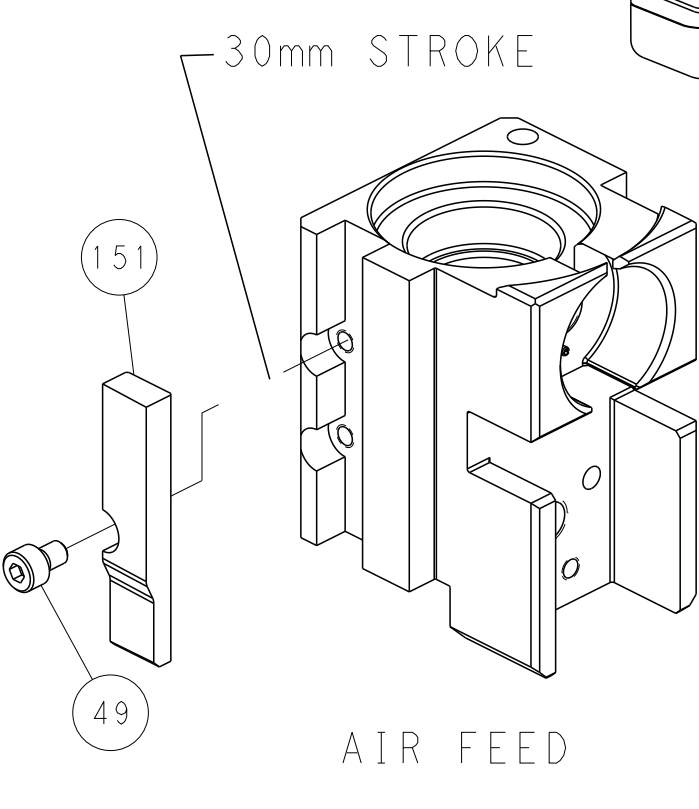

AIR FEED

**PACIFIC VERSION**  
 Shown on sheets 3 of 4 & 4 of 4  
 (Atlantic version shown on sheets 1 of 4 & 2 of 4)

<small>THIS DRAWING IS UNPUBLISHED. RELEASED FOR PUBLICATION. ALL RIGHTS RESERVED. © 2000 BY TYCO ELECTRONICS CORPORATION. THE INFORMATION IS CONSIDERED UNCLASSIFIED AND IS BEING RELEASED TO THE PUBLIC. FOR THE LATEST REVISIONS, CONTACT THE MANUFACTURER.</small>		DWN: X.ZHAO 28AUG2014 CHK: L.ZHANG 28AUG2014 APVD: T.ELBIN 28AUG2014	NAME: TE Connectivity Harrisburg, PA 17105-3608
DIMENSIONS: mm TOLERANCES UNLESS OTHERWISE SPECIFIED: 0 PLC ± 1 PLC ± 2 PLC ± 3 PLC ± 4 PLC ± ANGLES ± MATERIAL: - FINISH: -	PRODUCT SPEC: - APPLICATION SPEC: - WEIGHT: - SCALE: 1:2	SIZE: A1 CAGE CODE: 00779 DRAWING NO: C=2266473 SHEET 4 OF 4	RESTRICTED TO: - REV: C