

3 CONTACTS WILL BE SUPPLIED LOOSE

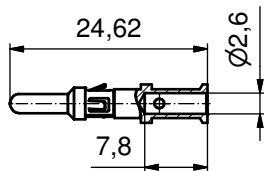

STRIPPING DIMENSIONS

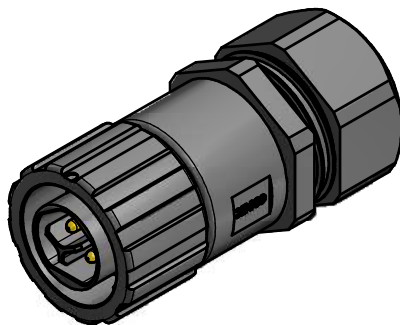
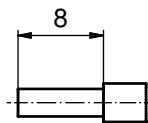

NOTES:

1. MATERIAL AND FINISH:

- COUPLER RING: PA GF (BLACK); UL94 V-0; UL (f1) RATED
- SOCKET HOUSING: PA GF (BLACK); UL94 V-0; UL (f1) RATED
- CABLE GLAND: PA (BLACK), UL94 V-0; UL (f1) RATED
- CABLE GLAND RUBBER RING: NBR; COLOR: BLACK
- CABLE FITTING: PA (BLACK); UL94 V-0; UL (f1) RATED
- INTERFACIAL SEAL: SILICONE; COLOR: WHITE
- RETAINING RING: STAINLESS STEEL

2. HIGH POWER CONTACTS; CRIMP; 20A



- FOR USE WITH CABLE AWG 12 - 14
- MATERIAL: COPPER ALLOY
- PLATING, MATING AREA: GOLD FLASH OVER NICKEL
- PLATING, TERMINATION SIDE: 160 - 240µin TIN OVER 80µin NICKEL
- PROTECTION SLEEVE: NICKEL PLATED
- CONTACTS WILL BE SUPPLIED LOOSE
- CRIMPING: USE CRIMP TOOL 360X21079X WITH TOOL INSERT 36-000430
- TURRET POSITION: 12
- SELECTOR SITTINGS: 8 FOR AWG 12, 7 FOR AWG 14

3. OPERATING TEMPERATURE: -40 °C to +100 °C

4. WORKING VOLTAGE: max. 300V AC/DC

5. IP67 RATED WHEN COVERED OR FULLY MATED WITH THE APPROPRIATE MATING CONNECTOR

RoHS compliant

THIS DRAWING MAY NOT BE COPIED OR REPRODUCED IN ANY WAY, AND MAY NOT BE PASSED ON TO A THIRD PARTY WITHOUT WRITTEN PERMISSION. OWNERSHIP AND COPYRIGHT OF CONEC GmbH DO NOT ALTER CAD DRAWING BY HAND	date		name		 scale: 1,5:1 material: see notes
	drawn	30.06.15	Henneboel		
	appd.	30.06.15	Strakerjahn		
	norm				
	d-old				dwg no: 17K1A469
a	Original				
rev.	description	date	name		part no: 17-400463