

PART NUMBER	REVISION	DESCRIPTION	FEED TYPE
2150524-2	D	FINE CRIMP HEIGHT ADJUST	PNEUMATIC
7-2150524-2	D	PNEUMATIC AND CRIMP TOOLING KIT	PNEUMATIC
7-2150524-7	A	CRIMP TOOLING KIT	-

ATLANTIC VERSION TERMINATOR INTERFACE ADAPTER

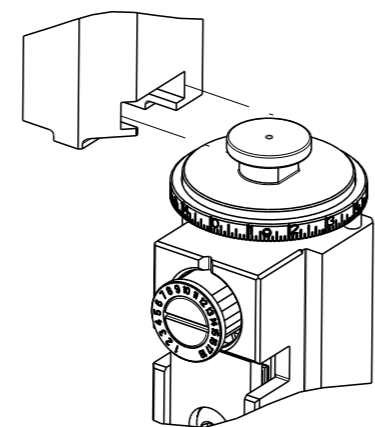

APPLICATOR DATA		
CRIMP	SIZE	TYPE
WIRE	5.33 mm [.210]	F
INSUL	7.62 mm [.300]	Ø
APPL INSTRUCTIONS 408-35043		

TERMINAL DATA: TE TERMINAL		TE CRIMP SPECIFICATION	
TERMINAL NAME: RING TERMINAL			
WIRE STRIP LENGTH		INSULATION DIAMETER RANGE	
4.39-5.16 mm [.173-.203 IN]		Ø3.81-5.59 mm [.150-.220 IN]	
TERMINAL APPLICATION SPECIFICATION	114-2084		
TERMINALS APPLIED			
TE TERMINAL	TE TERMINAL	TE TERMINAL	TE TERMINAL
61289-1	42947-2	42947-4	
42946-2	42947-3	640012-2	

WIRE SIZE	CRIMP HEIGHT mm [INCH]	CRIMP HEIGHT REFERENCE SETTING
8 AWG	4.04 +/- 0.05 [.159 +/- .002]	2.3
10 AWG	3.53 +/- 0.05 [.139 +/- .002]	8.4
12 AWG	3.23 +/- 0.05 [.127 +/- .002]	11.9

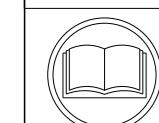

- RECOMMENDED SPARE PARTS
 - REFER TO SUPPLIED INSTRUCTION SHEET FOR CLEANING, LUBRICATION AND STORAGE OF APPLICATOR.
 - APPLY PART NUMBER 1-23419-5 LOCTITE TO THREADS OF ITEMS 180. APPLY PART NUMBER 2-23419-6 LOCTITE TO THREADS OF ITEM 242.
 - CRIMP HEIGHT REFERENCE SETTING WAS THE SETTING USED WHEN THE APPLICATOR WAS QUALIFIED AT THE FACTORY. ADJUSTMENT MAY BE NECESSARY WHEN RUNNING APPLICATOR IN THE FIELD.
 - TERMINAL LUBRICANT IS RECOMMENDED.
 - TERMINAL PITCH NOT COMPATIBLE WITH MECHANICAL FEED.
7. UNLESS SPECIFIED OTHERWISE TORQUE VALUES SHALL BE USED PER DOCUMENT, 101-35000.

***WARNING**
ON INSTALLATION, SET WIRE DISC TO CRIMP HEIGHT REFERENCE SETTING FOR LARGEST WIRE SIZE. CRIMP HEIGHT REFERENCE SETTINGS GREATER THAN THE VALUE SHOWN MAY CAUSE DAMAGE TO THE CRIMP TOOLING, REFER TO THE INSTRUCTION SHEET FOR PROPER SETUP AND ADJUSTMENTS.

ATLANTIC VERSION
Shown on sheets 1 of 4 & 2 of 4
(Pacific version shown on sheets 3 of 4 & 4 of 4)

LOC	DIST	REVISIONS					
A	66	P	LYH	DESCRIPTION	DATE	OWN	APVD
		B		ECR-16-006093	26APR2016	MR	GB
		C		ECR-20-007917	03JUN2020	FJ	TE
		D		ECR-20-008693	17JUN2020	JAH	RK

-	1	1	2119641-1	FEED CAM, AIR FEED	248
-	1	1	2119082-5	CAM, SNAIL, INSULATION ADJUSTMENT	244
-	1	1	2079764-1	WASHER, WAVE SPRING, CREST-TO-CREST	243
-	1	1	2119083-1	RETAINER, INSULATION DIAL	242
-	1	1	2844940-4	AIR FEED MODULE	238
-	1	1	1-18028-0	WASHER, FLAT, REG M8	192
-	1	1	1752354-2	STANDOFF, HOLD-DOWN	180
-	1	1	6-993111-6	PIN, SLOTTED SPRING 3.0 X 14.0	177
-	1	1	8-22280-7	SPRING, COMPRESSION	176
-	1	1	1752353-2	GUIDE PIN, HOLDDOWN	175
-	1	1	1901680-2	GUIDE PIN, HOLDDOWN	174
-	REF	REF	994970-2	COUNTER, MAGNETIC	164
-	1	1	2119955-2	ASSY, LUBRICATOR, END FEED	84
-	1	1	455888-7	SPACER, CRIMPER	82
-	1	1	1803607-4	DOCUMENTATION PACKAGE	71
-	2	2	2-18032-2	SCR, SET, FLT PNT, M3 X 10.0	70
-	1	1	2119740-1	TAG, IDENTIFICATION	67
-	2	2	2168078-1	SCREW, DRIVE, RH, RoHS, 2 x .188	66
-	1	1	1901681-1	HOLDDOWN, TERMINAL	65
-	1	1	2168083-2	SCR, SKT HD CAP, RoHS, M4 X 8.0	60
-	1	1	5-18022-5	SCR, HEX HD CAP, M4 X 6.0	59
-	4	4	2168400-1	SHCS, LOW HEAD, RoHS, M4 X 12	57
-	2	2	1-2168083-2	SCR, SKT HD CAP, RoHS, M4 X 25	56
-	2	2	5018030-1	NUT, HEX, REG, RoHS, M3	54
-	2	2	986965-8	NUT, LOCK, HEX, TORQUE (M4)	53
-	1	1	1-5018030-0	NUT, HEX, REG, RoHS, M3.5	52
-	1	1	2063961-1	FEED FINGER	51
-	1	1	18023-9	SCR, SKT HD CAP M4 X 6.0	49
-	1	1	1-2119655-1	APPLICATOR BASIC ASSEMBLY, EF	46
-	1	1	1803517-1	RAM ASSEMBLY, EF ATLANTIC	44
-	1	1	1803602-1	SCR, BHSC, RoHS (M8 X 25)	41
-	8	8	1-18028-2	WASHER, FLAT, REG M4	33
-	2	2	2168083-9	SCR, SKT HD CAP, RoHS, M4 X 20	31
-	2	2	2168083-2	SCR, SKT HD CAP, RoHS, M4 X 8.0	29
-	1	1	690455-1	STRIPPER, FRONT CASTING	27
-	2	2	1-2168083-6	SCR, SKT HD CAP, RoHS, M4 X 35	25
-	1	1	1752371-5	PLATE, STRIP GUIDE	24
-	2	2	2-22281-3	SPRING, COMPRESSION	22
-	1	1	1803292-4	DRAG	20
-	1	1	4-1901696-1	STRIP GUIDE, REAR	19
-	1	1	4-1901695-1	STRIP GUIDE, FRONT	18
-	4	4	1-2079383-1	SCR, BHSC, RoHS (M6 X 12)	17
-	1	1	3-240641-0	SPACER	16
-	1	1	1752360-1	SPACER, HOLD-DOWN	13
-	1	1	240644-1	PLATE, REAR SHEAR	11
-	2	2	1-240645-1	SPACER, SHEAR PLATE	10
-	1	1	240642-1	PLATE, FRONT SHEAR	9
-	1	2	1-1803059-9	ANVIL, COMBINATION, END FEED	8
-	1	1	8-240651-2	BLADE, SLUG	7
-	-	-	-	-	6
-	1	1	7-240641-3	SPACER	5
-	1	1	1-238011-4	BLOCK, CRIMPER SPACER	4
-	1	2	1-1633965-4	CRIMPER, INSULATION O PREMIUM	3
-	1	1	1-455888-4	SPACER, CRIMPER	2
-	1	2	1-456430-6	CRIMPER, WIRE	1
-	77	72	-2	PART NO	ITEM NO

DIMENSIONS:		TOLERANCES UNLESS OTHERWISE SPECIFIED:		DATE	
mm	0 PLC ±	1 PLC ±	2 PLC ±	12 JAN 2015	OWN
	3 PLC ±	4 PLC ±	5 PLC ±	12 JAN 2015	CHK
	ANGLES	FINISH			APVD
MATERIAL				WEIGHT	
-				-	

Customer Accessible Production Drawing		SCALE	1:1	SHEET	1	OF	4	REV	D
--	--	-------	-----	-------	---	----	---	-----	---

LOC		DIST		REVISIONS			
A	66	P	LYR	DESCRIPTION	DATE	OWN	APVD
		-		SEE SHEET 1			

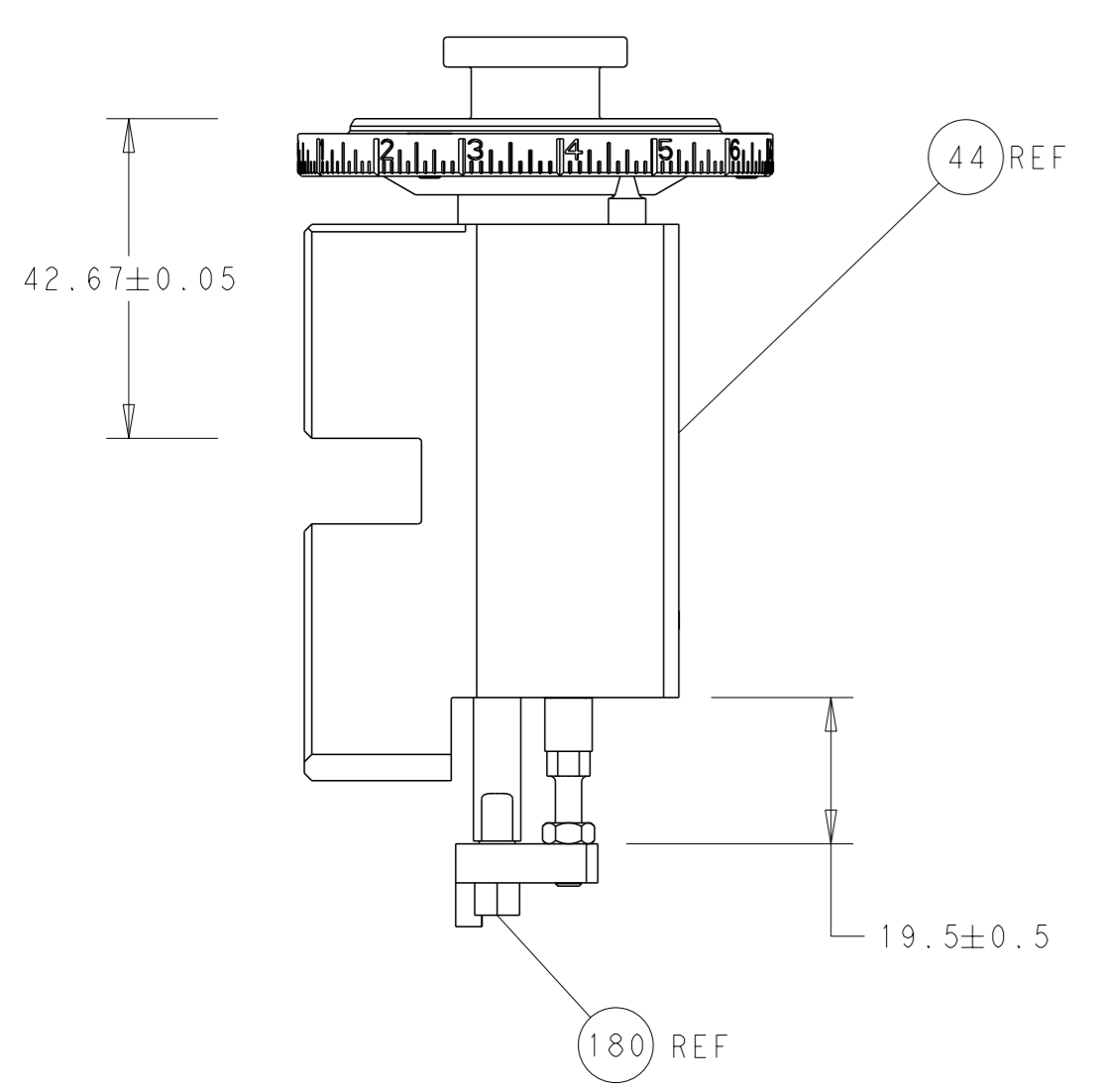

RAM AND HOLDDOWN SET-UP

FEED TYPE

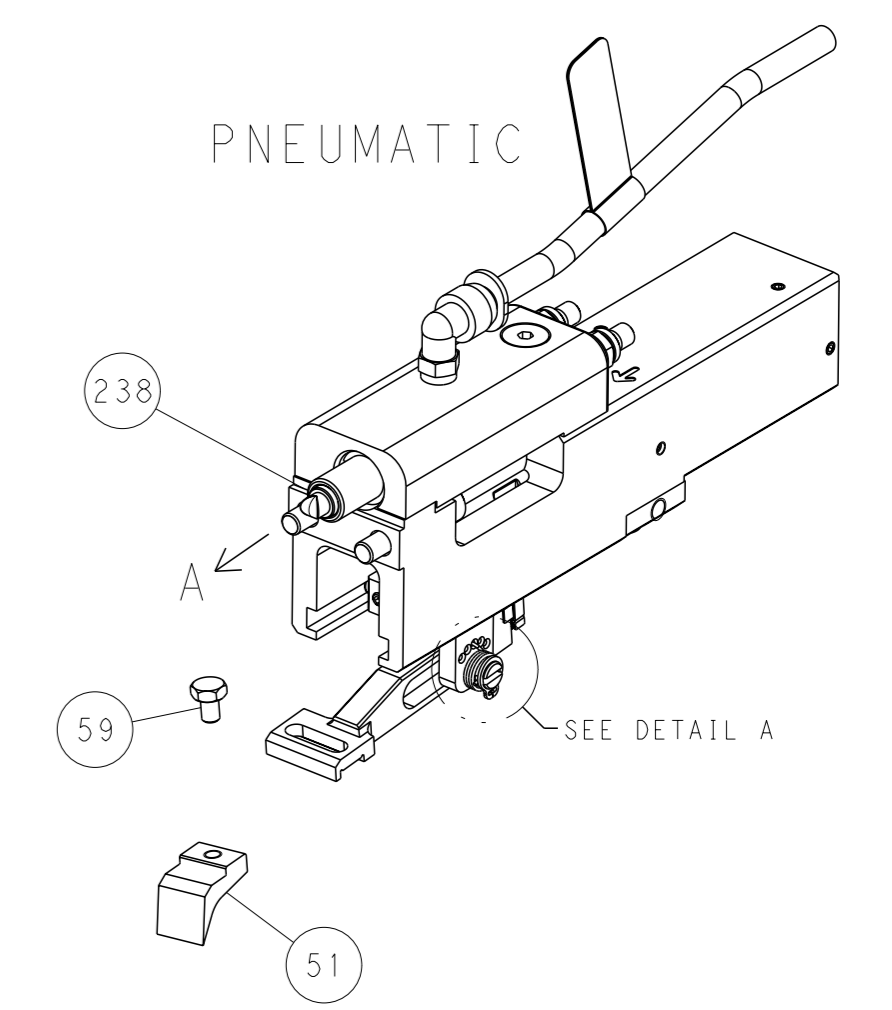

FEED SPRING SETTING POSITION

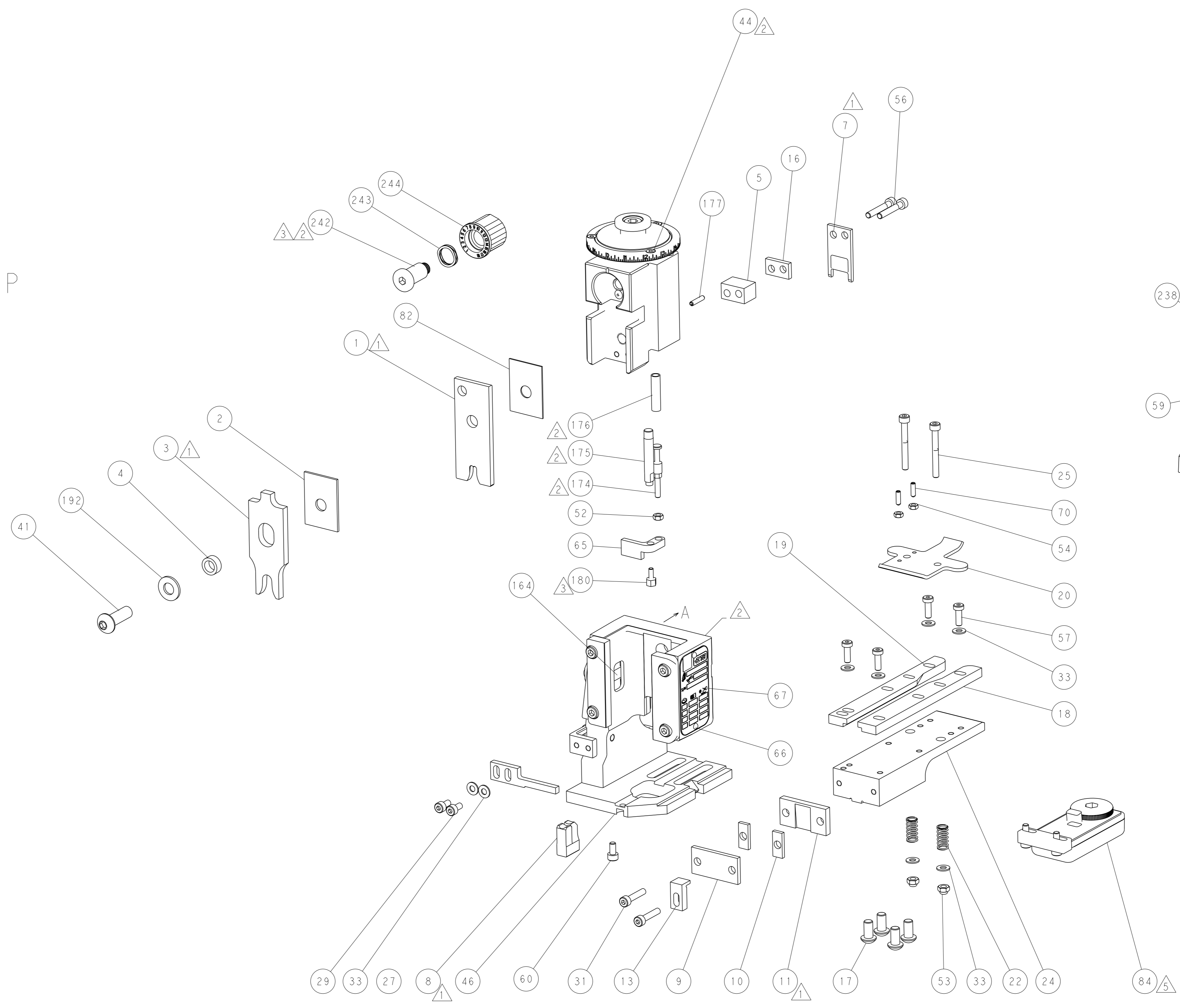
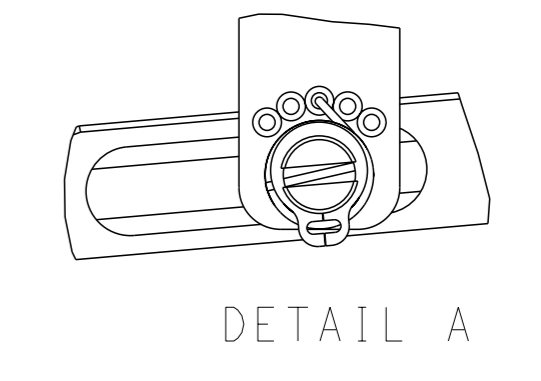

CAM POSITION

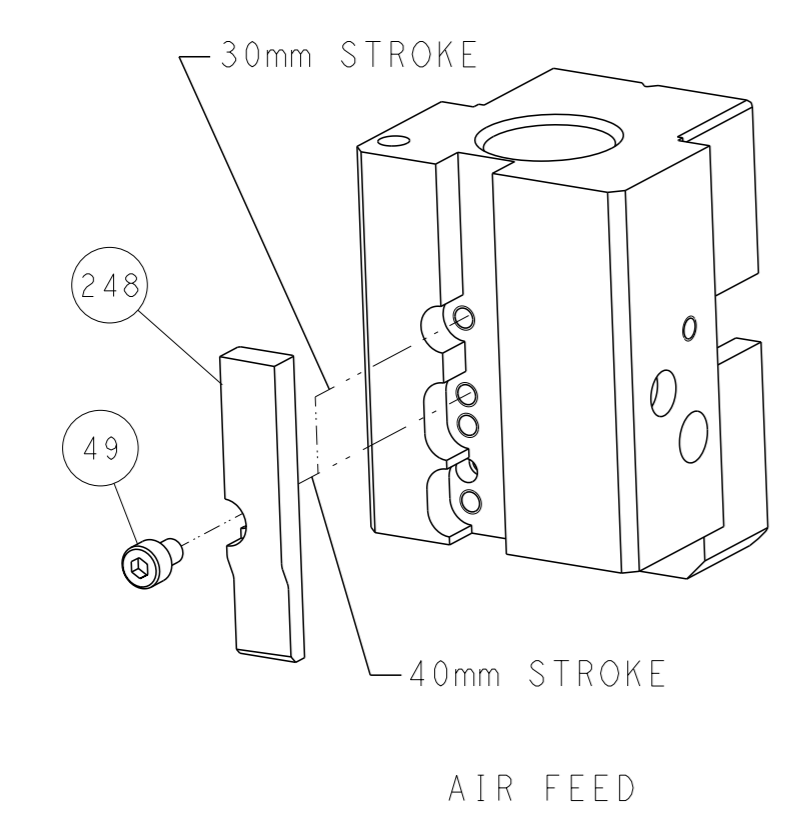

ATLANTIC VERSION
 Shown on sheets 1 of 4 & 2 of 4
 (Pacific version shown on sheets 3 of 4 & 4 of 4)

<small>THIS DRAWING IS A CONTROLLED DOCUMENT FOR TYCO ELECTRONICS CORPORATION. IT IS SUBJECT TO CHANGE AND THE CONTROL AND ENGINEERING DESIGNATION SHOULD BE CONTACTED FOR THE LATEST REVISION.</small>		OWN: J. HOU 12JAN2015 CHK: L. ZHANG 12JAN2015 APVD: H. GUO 12JAN2015	NAME: Ocean End Feed Applicator SIZE: A1 CAGE CODE: 00779 DRAWING NO: C=2150524	RESTRICTED TO: - SCALE: 1:1 SHEET: 2 of 4 REV: D
DIMENSIONS: mm TOLERANCES UNLESS OTHERWISE SPECIFIED: 0 PLC ± 1 PLC ± 2 PLC ± 3 PLC ± 4 PLC ± ANGLES FINISH ±	MATERIAL: - FINISH: -	WEIGHT: - APPLICATION SPEC: - PRODUCT SPEC: -	TE Connectivity Harrisburg, PA 17105-3608	

THIS DRAWING IS UNPUBLISHED.	RELEASED FOR PUBLICATION	20	
COPYRIGHT 20 BY TYCO ELECTRONICS CORPORATION. ALL RIGHTS RESERVED.			
PART NUMBER	REVISION	DESCRIPTION	FEED TYPE
2-2150524-2	D	FINE CRIMP HEIGHT ADJUST	PNEUMATIC
7-2150524-7	A	CRIMP TOOLING KIT	-

PACIFIC VERSION TERMINATOR
INTERFACE ADAPTER

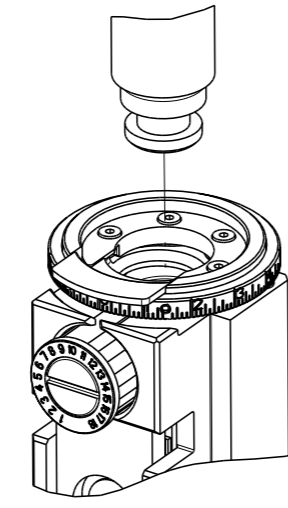

APPLICATOR DATA		
CRIMP	SIZE	TYPE
WIRE	5.33 mm [.210]	F
INSUL	7.62 mm [.300]	O
APPL INSTRUCTIONS 408-35043		

TERMINAL DATA: TE TERMINAL		TE CRIMP SPECIFICATION	
TERMINAL NAME: RING TERMINAL			
WIRE STRIP LENGTH 4.39-5.16 mm [.173-.203 IN]		INSULATION DIAMETER RANGE Ø3.81-5.59 mm [1.150-.220 IN]	
TERMINAL APPLICATION SPECIFICATION	114-2084	-	-
TERMINALS APPLIED			
TE TERMINAL	TE TERMINAL	TE TERMINAL	TE TERMINAL
61289-1	42947-2	42947-4	
42946-2	42947-3	640012-2	

WIRE SIZE	CRIMP HEIGHT mm [INCH]	CRIMP HEIGHT REFERENCE SETTING
8 AWG	4.04 +/- 0.05 [1.159 +/- .002]	2.3
10 AWG	3.53 +/- 0.05 [1.139 +/- .002]	8.4
12 AWG	3.23 +/- 0.05 [1.127 +/- .002]	11.9

- 1. RECOMMENDED SPARE PARTS
- 2. REFER TO SUPPLIED INSTRUCTION SHEET FOR CLEANING, LUBRICATION AND STORAGE OF APPLICATOR.
- 3. APPLY PART NUMBER 1-23419-5 LOCTITE TO THREADS OF ITEMS 180. APPLY PART NUMBER 2-23419-6 LOCTITE TO THREADS OF ITEM 242.
- 4. CRIMP HEIGHT REFERENCE SETTING WAS THE SETTING USED WHEN THE APPLICATOR WAS QUALIFIED AT THE FACTORY. ADJUSTMENT MAY BE NECESSARY WHEN RUNNING APPLICATOR IN THE FIELD.
- 5. TERMINAL LUBRICANT IS RECOMMENDED.
- 6. TERMINAL PITCH NOT COMPATIBLE WITH MECHANICAL FEED.
- 7. UNLESS SPECIFIED OTHERWISE TORQUE VALUES SHALL BE USED PER DOCUMENT, 101-35000.

***WARNING**
ON INSTALLATION, SET WIRE DISC TO CRIMP HEIGHT REFERENCE SETTING FOR LARGEST WIRE SIZE. CRIMP HEIGHT REFERENCE SETTINGS GREATER THAN THE VALUE SHOWN MAY CAUSE DAMAGE TO THE CRIMP TOOLING, REFER TO THE INSTRUCTION SHEET FOR PROPER SETUP AND ADJUSTMENTS.

PACIFIC VERSION
Shown on sheets 3 of 4 & 4 of 4
(Atlantic version shown on sheets 1 of 4 & 2 of 4)

LOC	DIST	REVISIONS					
A	66	P	LYR	DESCRIPTION	DATE	OWN	APVD
		-		SEE SHEET 1	-	-	-

3	-	1	2119082-5	CAM, SNAIL, INSULATION ADJUSTMENT	244
	-	1	2079764-1	WASHER, WAVE SPRING, CREST-TO-CREST	243
	-	1	2119083-1	RETAINER, INSULATION DIAL	242
	-	1	2844940-4	AIR FEED MODULE	238
	-	1	1-18028-0	WASHER, FLAT, REG M8	192
	-	4	2079383-9	SCR, BHSC, RoHS (M6 X 20)	186
3	-	1	1752354-2	STANDOFF, HOLD-DOWN	180
	-	1	6-993111-6	PIN, SLOTTED SPRING 3.0 X 14.0	177
	-	1	8-22280-7	SPRING, COMPRESSION	176
	-	1	1752353-2	GUIDE PIN, HOLDDOWN	175
	-	1	1901680-2	GUIDE PIN, HOLDDOWN	174
	-	REF	994970-2	COUNTER, MAGNETIC	164
	-	1	2119641-2	FEED CAM, AIR FEED	152
	-	1	2168083-8	SCR, SKT HD CAP, RoHS, M4 X 16	144
	-	1	1-2119655-2	APPLICATOR BASIC ASSEMBLY, EF	141
	-	1	1803518-1	RAM ASSEMBLY, EF PACIFIC	140
5	-	1	2119955-2	ASSY, LUBRICATOR, END FEED	84
	-	1	455888-7	SPACER, CRIMPER	82
	-	1	1803607-4	DOCUMENTATION PACKAGE	71
	-	2	2-18032-2	SCR, SET, FLT PNT, M3 X 10.0	70
	-	1	2119740-1	TAG, IDENTIFICATION	67
	-	2	2168078-1	SCREW, DRIVE, RH, RoHS, 2 x .188	66
	-	1	1901681-1	HOLDDOWN, TERMINAL	65
	-	1	5-18022-5	SCR, HEX HD CAP, M4 X 6.0	59
	-	4	2168400-1	SHCS, LOW HEAD, RoHS, M4 X 12	57
	-	2	1-2168083-2	SCR, SKT HD CAP, RoHS, M4 X 25	56
	-	2	5018030-1	NUT, HEX, REG, RoHS, M3	54
	-	2	986965-8	NUT, LOCK, HEX, TORQUE (M4)	53
	-	1	1-5018030-0	NUT, HEX, REG, RoHS, M3.5	52
	-	1	2063961-1	FEED FINGER	51
	-	1	18023-9	SCR, SKT HD CAP M4 X 6.0	49
	-	1	1803602-1	SCR, BHSC, RoHS (M8 X 25)	41
	-	8	1-18028-2	WASHER, FLAT, REG M4	33
	-	2	2168083-9	SCR, SKT HD CAP, RoHS, M4 X 20	31
	-	2	2168083-2	SCR, SKT HD CAP, RoHS, M4 X 8.0	29
	-	1	690455-1	STRIPPER, FRONT CASTING	27
	-	2	1-2168083-6	SCR, SKT HD CAP, RoHS, M4 X 35	25
	-	1	1752371-5	PLATE, STRIP GUIDE	24
	-	2	2-22281-3	SPRING, COMPRESSION	22
	-	1	1803292-4	DRAG	20
	-	1	4-1901696-1	STRIP GUIDE, REAR	19
	-	1	4-1901695-1	STRIP GUIDE, FRONT	18
	-	1	3-240641-0	SPACER	16
	-	1	1752360-1	SPACER, HOLD-DOWN	13
1	-	1	240644-1	PLATE, REAR SHEAR	11
	-	2	1-240645-1	SPACER, SHEAR PLATE	10
1	-	1	240642-1	PLATE, FRONT SHEAR	9
1	1	1	1-1803059-9	ANVIL, COMBINATION, END FEED	8
1	-	1	8-240651-2	BLADE, SLUG	7
	-	-	-	-	6
	-	1	7-240641-3	SPACER	5
	-	1	1-238011-4	BLOCK, CRIMPER SPACER	4
1	1	1	8-1633965-4	CRIMPER, INSULATION O PREMIUM	3
	-	1	1-455888-4	SPACER, CRIMPER	2
1	1	1	1-456430-6	CRIMPER, WIRE	1
	-	77-22	PART NO	DESCRIPTION	ITEM NO

DIMENSIONS:		TOLERANCES UNLESS OTHERWISE SPECIFIED:		OWN	J. HOU	12JAN2015	NAME	Ocean End Feed Applicator
mm	0 PLC ±	1 PLC ±	2 PLC ±	CHK	L. ZHANG	12JAN2015		
	3 PLC ±	4 PLC ±	5 PLC ±	APVD	U. GUO	12JAN2015	SIZE	A1
	ANGLES	FINISH		PRODUCT SPEC			CAGE CODE	00779
MATERIAL				APPLICATION SPEC			DRAWING NO	2150524
				WEIGHT			SCALE	1:1
							SHEET	3 of 4
							REV	D

LOC		DIST		REVISIONS			
P	LYR	DESCRIPTION	DATE	OWN	APVD		
A	66	SEE SHEET 1					

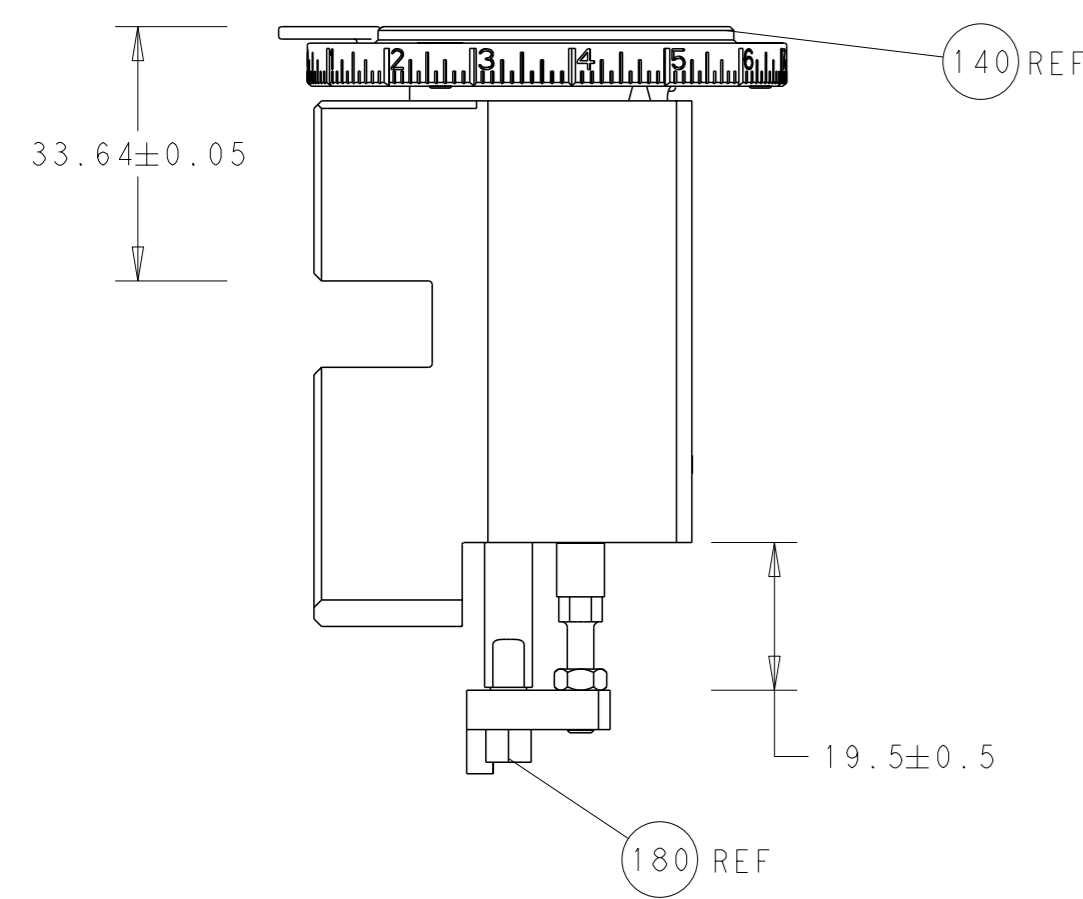

RAM AND HOLDDOWN SET-UP

FEED TYPE

PNEUMATIC

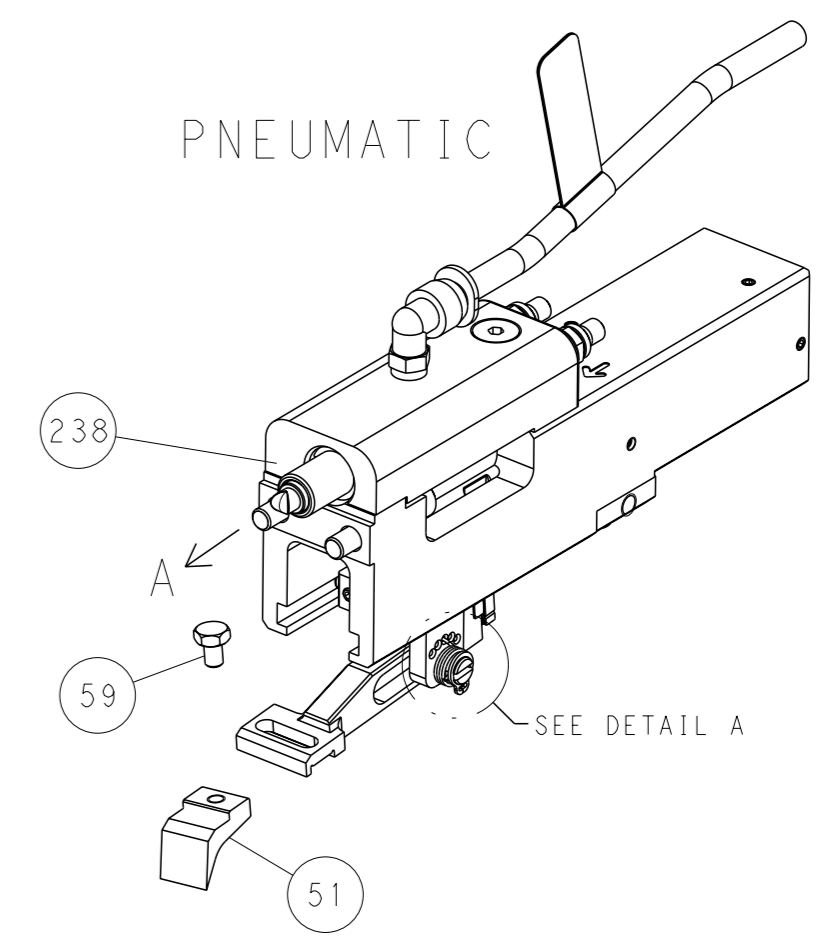

FEED SPRING SETTING POSITION

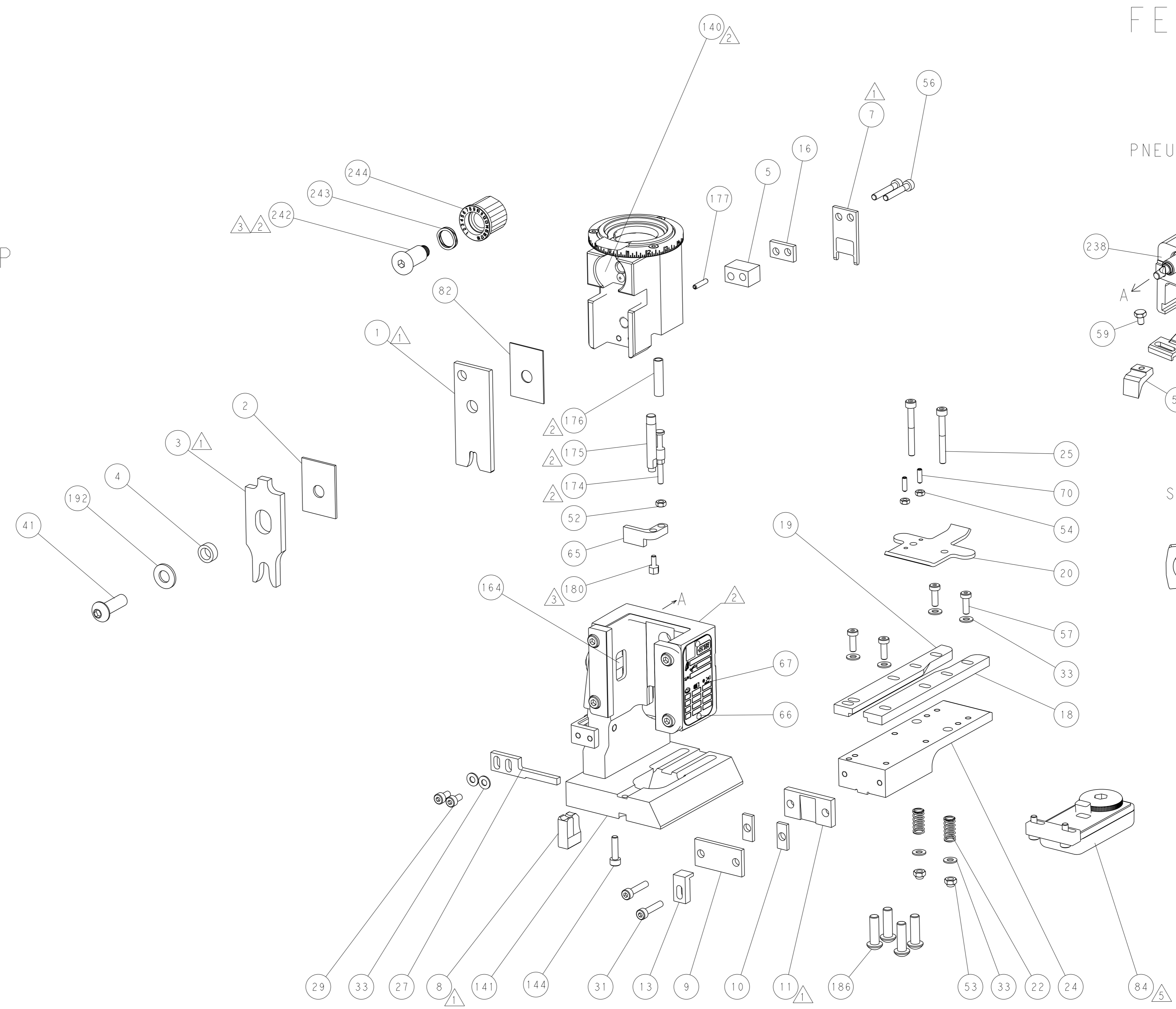
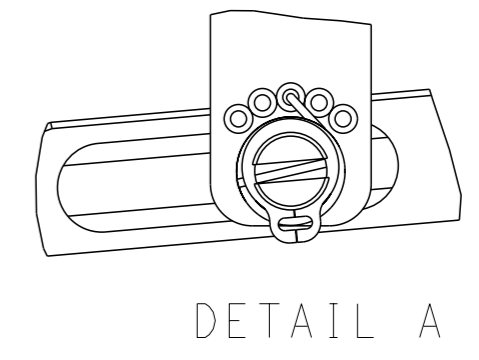

CAM POSITION

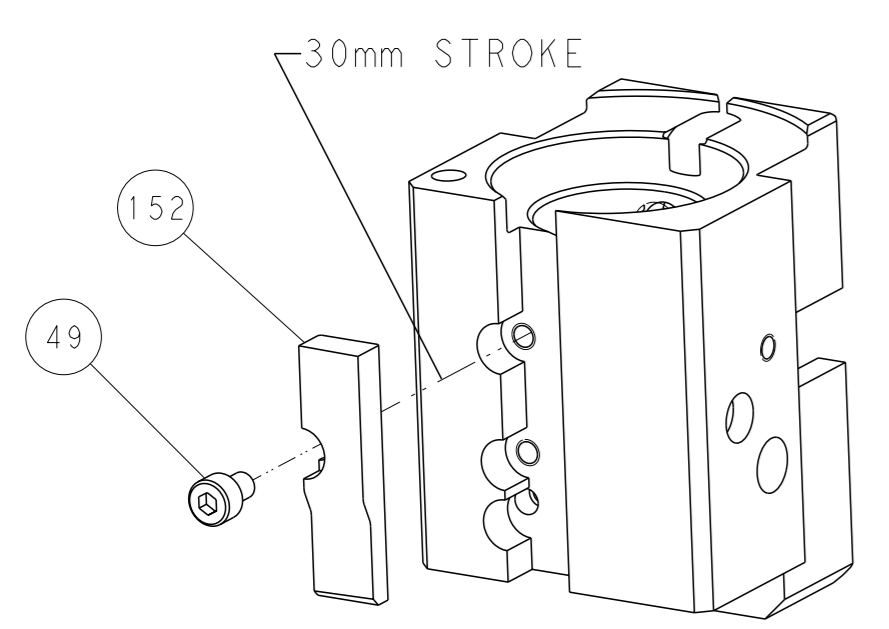

AIR FEED

PACIFIC VERSION
 Shown on sheets 3 of 4 & 4 of 4
 (Atlantic version shown on sheets 1 of 4 & 2 of 4)

<small>THIS DRAWING IS A CONTROLLED DOCUMENT FOR TYCO ELECTRONICS CORPORATION. IT IS SUBJECT TO CHANGE AND THE USER'S RESPONSIBILITY TO OBTAIN THE LATEST REVISION SHOULD BE CONTACTED FOR THE LATEST REVISION.</small>		OWN: J. HOU CHK: L. ZHANG APVD: H. GUO DATE: 12JAN2015 DATE: 12JAN2015 DATE: 12JAN2015	NAME: Ocean End Feed Applicator SIZE: A1 CAGE CODE: 00779 DRAWING NO: C=2150524 SCALE: 1:1 SHEET: 4 of 4 REV: D
DIMENSIONS: mm TOLERANCES UNLESS OTHERWISE SPECIFIED: 0 PLC ± 1 PLC ± 2 PLC ± 3 PLC ± 4 PLC ± ANGLES FINISH ±	MATERIAL:	WEIGHT:	RESTRICTED TO: