

PAGE 1/2

ISSUE 22-03-22

SERIE : DPDT

PART NUMBER : R577133005

RF CHARACTERISTICS

Frequency range : **0 - 12.4 GHz**
 Impedance : **50 Ohms**

Frequency (GHz)	DC - 1	1 - 2	2 - 3	3 - 8	8 - 12.4
VSWR max	1.15	1.20	1.25	1.35	1.50
Insertion loss max	0.15 dB	0.20 dB	0.25 dB	0.35 dB	0.50 dB
Isolation min	85 dB	80 dB	75 dB	70 dB	60 dB
Average power (*)	700 W	500 W	400 W	250 W	200 W

ELECTRICAL CHARACTERISTICS

Actuator : **LATCHING**
 Nominal current ** : **125 mA**
 Actuator voltage (Vcc) : **28V (24 to 30V) / NEGATIVE COMMON**
 Terminals : **9 pins D-SUB male connector**

MECHANICAL CHARACTERISTICS

Connectors : **N female per MIL-C 39012**
 Life : **2.5 million cycles**
 Switching Time*** : **< 15 ms**
 Construction : **Splashproof**
 Weight : **< 215 g**

ENVIRONMENTAL CHARACTERISTICS

Operating temperature range : **-40°C to +85°C**
 Storage temperature range : **-55°C to +85°C**

(* Average power at 25°C per RF Path)

(** At 25° C ±10%)

(*** Nominal voltage ; 25° C)



PAGE 2/2

ISSUE 22-03-22

SERIE : DPDT

PART NUMBER : R577133005

DRAWING

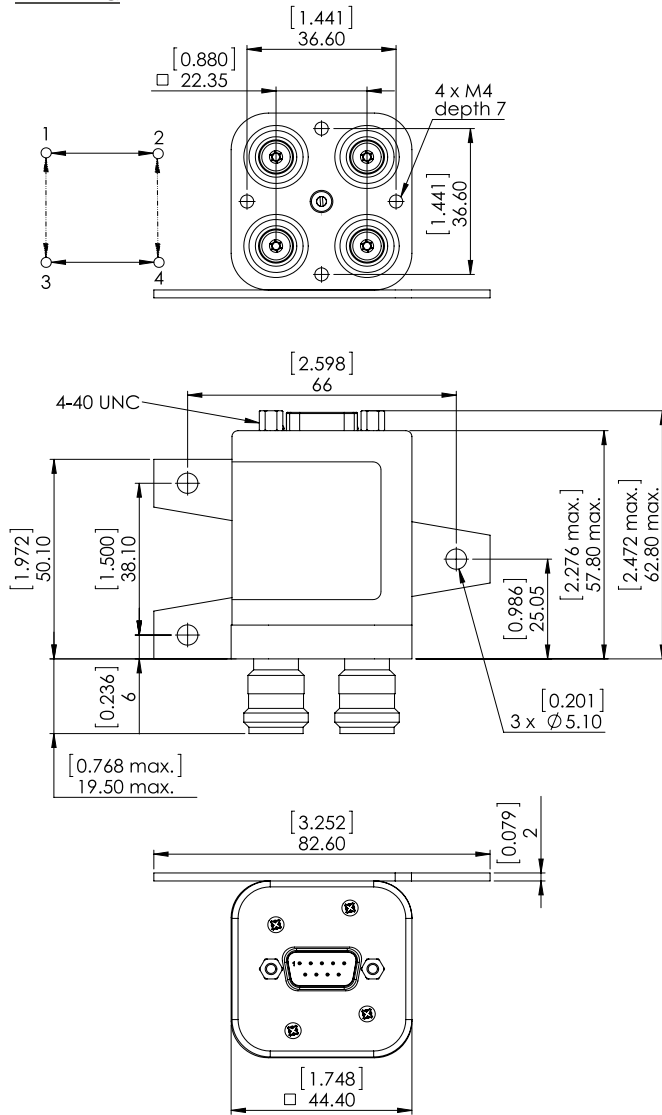

General tolerances : ±0,5 mm [0,02 in]

LABEL

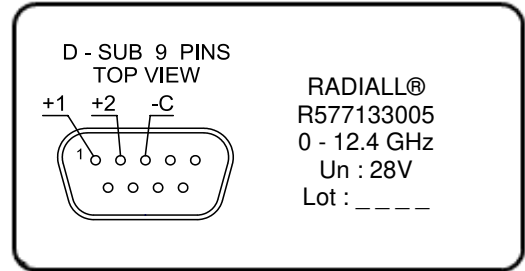

SCHEMATIC DIAGRAM

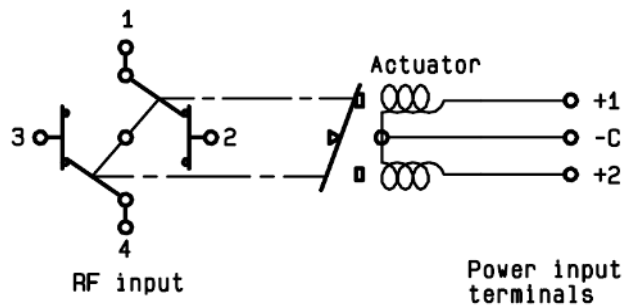

Voltage	RF Continuity
-C +1	1 ↔ 3 / 2 ↔ 4
-C +2	1 ↔ 2 / 3 ↔ 4