



Shown at right with  
disposable wipes  
(Wipes not included and are  
not sold by BOWMAN.)



**MADE  
IN THE USA**  
PATENTED

### Product Description:

- Disposable Wipe Bracket - Universal
- Front loading canister
- Holds a wide variety of wipe canister sizes
- Screw holes for wall or cabinet mounting, or attaches to pole mount (BWX02-0412, sold separately)
- Quartz Beige Powder-Coated Aluminum

### Primary Area for Product Usage:

- Anywhere disposable wipes are needed

### Dispenses:

- Wipe canisters from 2.88" to 5.00" (7.3 cm to 12.7 cm) in diameter

### Package Specifications:

- Package Quantity: 12 per case
- 14"L x 12"W x 9"H (35.6 cm x 30.5 cm x 22.9 cm)
- 9.0 lbs (4.1 kg) - approximated

### Product Specifications (overall external dimensions):

- 3.48"W x 5.65"H x 5.00"D (8.8 cm x 14.4 cm x 12.7 cm)
- 0.6 lbs (0.3 kg) - approximated

### Mounting Specifications:

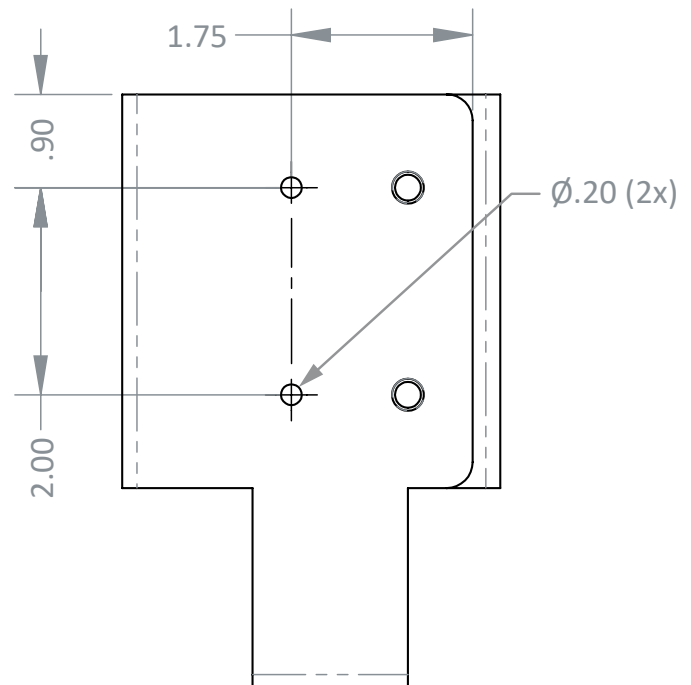

### Accessorie(s) (each sold separately):

- BWX02-0412: Pole Mount (shown below)
- KS022-0012: Dual-Sided Floor Stand





## Installation

Always mount dispensers securely *prior* to loading with product.

- Mount part A securely to a wall with screws approved and supplied by building maintenance.
- Align part B slots over the attached studs on part A.

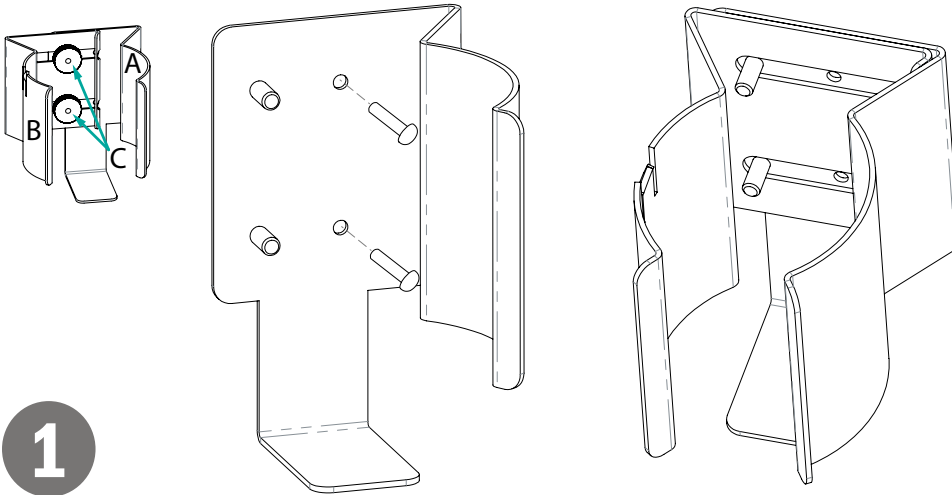

1

- Place one washer and one knurled knob over each of the two studs. Do not tighten.
- Insert desired canister to determine spacing. Point of part B should grip the canister. Move part B so it is tight.
- Remove canister and tighten knobs. Replace canister.

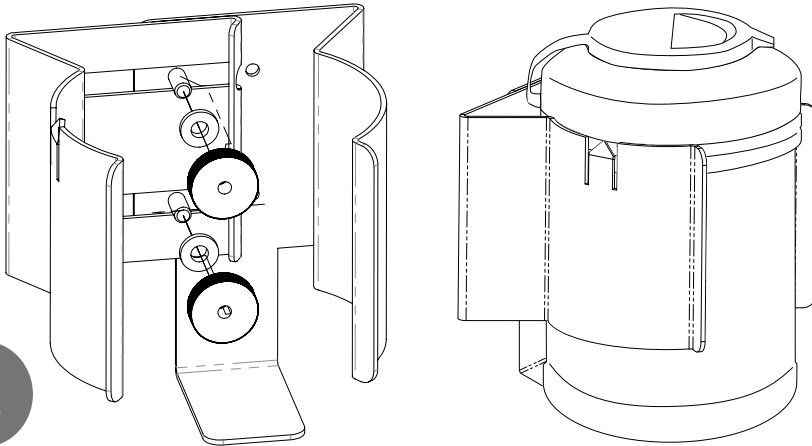

2

### Parts included:

- Dispenser (two parts)
- (2x) washers and (2x) knurled knobs

### Tools Required:

- No tools required to assemble dispenser

## Care and Construction

### Powder-Coated Aluminum

### Material Characteristics

### Designed for Long-Term Use

Our Powder-Coated Aluminum dispensers resist corrosion, chipping, and flaking. It is lightweight, yet high in strength. This material will provide long-lasting products that hold up well, even in tough environments.

Powder-Coated Aluminum is ideal for dispensers used in a healthcare or industrial settings. It is impact resistant and is not affected by extremes in temperature.

Powder-Coated Aluminum is clean, bright, and attractive; it creates a professional appearance.

### Care and Cleaning

For best results, clean by washing the surface with a diluted solution of a mild, non-abrasive detergent in cold or warm water and a non-abrasive cloth. Standard hospital cleaning supplies can be used. Dry with a soft cloth. Do not use any solvent-based materials, abrasives (e.g. Scotch-brite, steel wool), or apply excessive force during cleaning.