

P	LTR	DESCRIPTION	DATE	DWN	APVD
	A	REVISED PER ECN-22-147532	07APR2022	RZ	WK

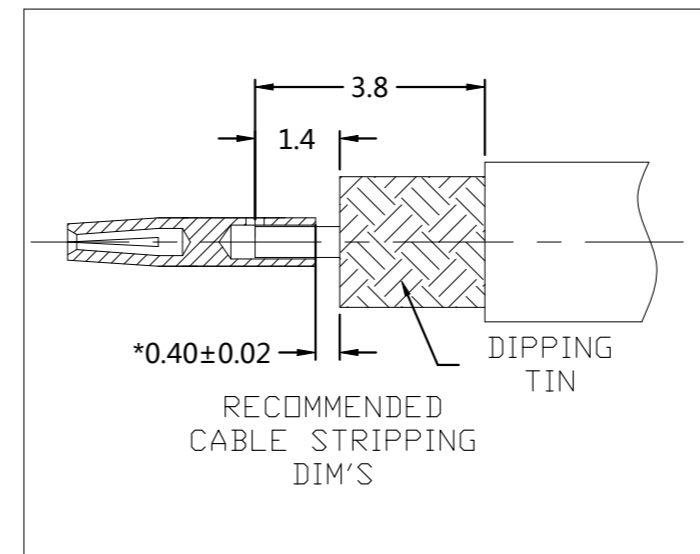
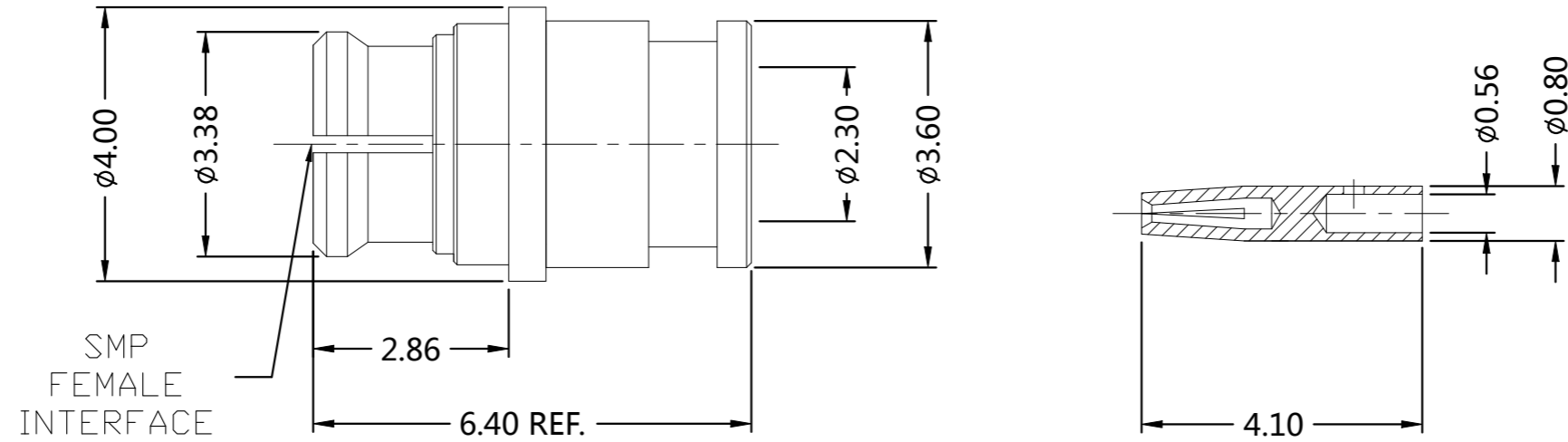

ELECTRICAL	MECHANICAL	ENVIRONMENTAL
Impedance (Ohm) <u>50</u>	Interface Dimension MIL-STD-348B Fig. <u>326-1a</u>	TEMPERATURE RANGE <u>-40°C TO + 125°C</u>
Frequency Range (GHz) <u>DC to 18GHz</u>	Force to Engage (lbs) Full Detent 15.0 Max Limited Detent 10.0 Max Smooth Bore 2.0 Max	THERMAL SHOCK <u>MIL-STD-202, METH.107, COND.B</u>
Voltage Rating (Peak) <u>175 V RMS</u> @ Sea Level	Force to Disengage (lbs) Full Detent 5.0 Max Limited Detent 2.0 Max Smooth Bore 0.5 Max	CORROSION <u>MIL-STD-202, METH.101, COND.B</u>
Insulation Resistance (MIN.) <u>1000 M ohms</u>	Center Contact Captivation Axial (Lbs) <u>1.5</u> Radial (In/Oz) <u>N/A</u>	VIBRATION <u>MIL-STD-202, METH.204, COND.D</u>
Contact Resistance (Milliohms MAX) Center Contact <u>6.0</u> Outer Contact <u>2.0</u>	Cable Retention Axial (Lbs) <u>N/A</u>	SHOCK <u>MIL-STD-202, METH.213, COND.I</u>
Dielectric Withstand Voltage: <u>500 V RMS Max</u>	Mating cycles <u>500</u> cycles	MOISTURE RESISTANCE <u>MIL-STD-202, METH.106,</u>
Insertion Loss : <u>0.1*SQRT(F) dB</u>		ROHS <u>COMPLIANT</u>
VSWR: <u>1.3 MAX (GHz)</u>		
RF leakage: <u>N/A</u>		

QUANTITY PER ASSY	PARTS LIST
1	Au3u" BRASS BODY 3
1	PTFE INSULATION 2
1	Au5u" BeCu CENTER CONTACT 1
-1	PLATING MATERIAL DESCRIPTION ITEM

THIS DRAWING IS A CONTROLLED DOCUMENT.

DWN	RANDY Z	16FEB2022
CHK	ERIC D	16FEB2022
APVD	WENKE H	16FEB2022
PRODUCT SPEC		
APPLICATION SPEC		
WEIGHT	-	

**STE** TE Connectivity

SMP JACK ST FOR CABLE TFLEX-405

SIZE	CAGE CODE	DRAWING NO	RESTRICTED TO
A3	00779	C-2406855	-

CUSTOMER DRAWING SCALE 1:1 SHEET 1 OF 1 REV A