

THIS DRAWING IS UNPUBLISHED. RELEASED FOR PUBLICATION 20
 © COPYRIGHT 20 BY - ALL RIGHTS RESERVED.

REVISIONS				
P	LTR	DESCRIPTION	DATE	APVD
E		ECR-17-012802	06SEP2017	KG DW
EI		ECR-17-018829	02JAN2018	KG DW

- 1 MATERIAL: PROTECTIVE COVER: TPE, COLOR:BLACK, UL 94 HB. *
- FERRULE SUB ASSEMBLY: ZIRCONIA/METAL
- COMPRESSION SPRING: STAINLESS STEEL.
- CONNECTOR HOUSING: PBT, COLOR:BLUE, UL 94 V-0. *
- PLUG BODY: PAS, COLOR: BEIGE, UL 94 V-0. *
- REAR BODY: METAL
- BOOT: PP, COLOR:BLUE, UL 94 V-0. *
- CRIMP EYELET/HEAT SHRINK ASSY: ALUM. ALLOY, HEAT SHRINK: POLYOLEFIN, UL VW-1.
- *RATED AT QUALIFYING THICKNESS.

2 BULK PACKAGED

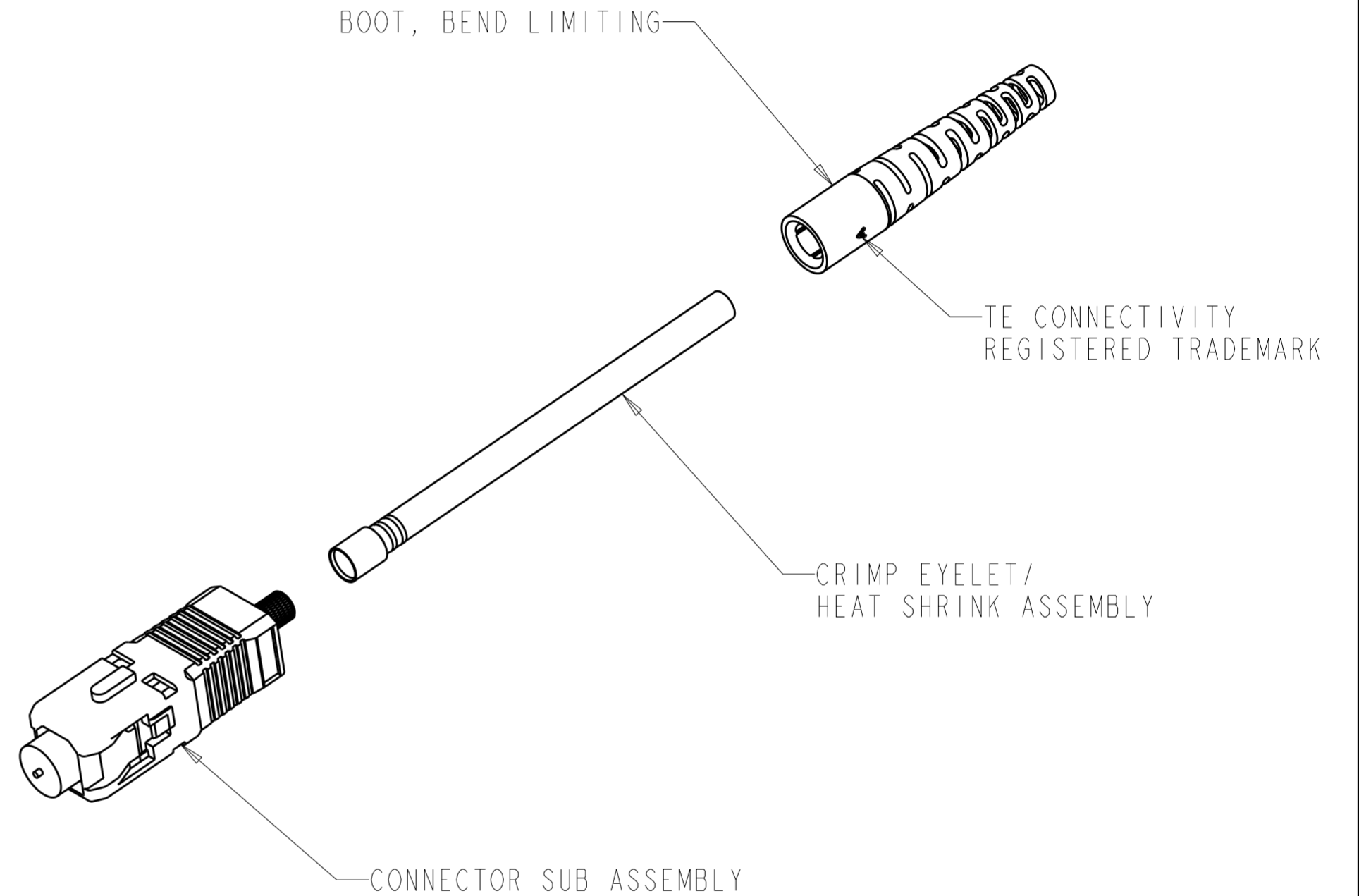
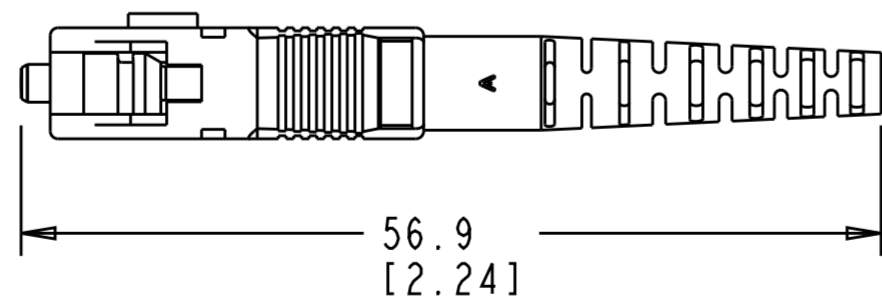
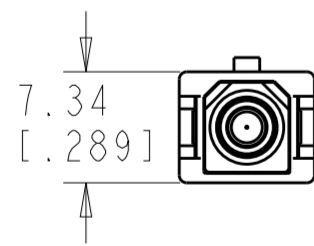
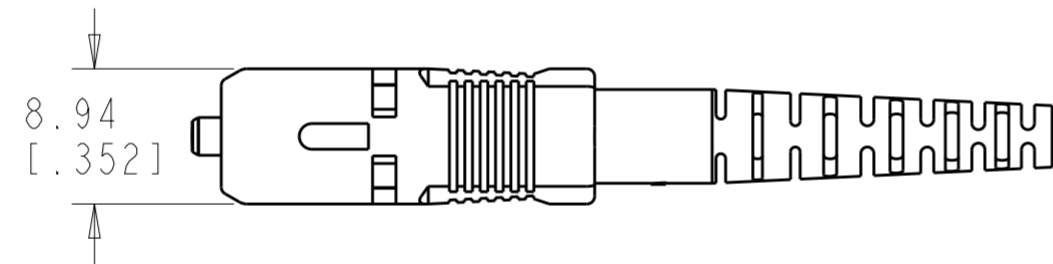

2 6828100-2
 6828100-1
 PART NUMBER

THIS DRAWING IS A CONTROLLED DOCUMENT.		DWN E HALEY 14OCT2005	TE Connectivity	
DIMENSIONS: mm [INCHES]		CHK D ROHDE 14OCT2005		
TOLERANCES UNLESS OTHERWISE SPECIFIED:		APVD D ROHDE 14OCT2005	NAME CONNECTOR KIT, SC, SIMPLEX SM, JUMPER, TIGHT JACKET STYLE, 1.6-2.0mm	
0 PLC ±		PRODUCT SPEC	SIZE	CAGE CODE
1 PLC ±0.1/[0.004]		APPLICATION SPEC	A2	00779
2 PLC ±0.01/[0.0004]		WEIGHT	DRAWING NO G-6828100	
3 PLC ±		CUSTOMER DRAWING	SCALE	3:1
4 PLC ±			SHEET	OF
ANGLES ±			REV	EI
FINISH -				