

MSC8254 High-Performance Multicore DSP

Four-core programmable DSP for medical imaging, aerospace, defense and advanced test and measurement

Overview

The MSC8254 is based on the industry's highest performance DSP core, built on StarCore technology, and designed for the advanced processing requirements and capabilities of today's high-performance medical imaging, aerospace, defense and advanced test and measurement markets. It delivers industry-leading performance and power savings, leveraging 45 nm process technology in a highly integrated SoC to provide performance equivalent to 4 GHz of a single-core device. The MSC8254 will help equipment manufacturers create end products

and services that integrate more functionality in a smaller hardware footprint.

The MSC8254 DSP delivers a high level of performance and integration, combining four fully programmable, new and enhanced SC3850 DSP cores, each running at up to 1 GHz. The SC3850 DSP core has been independently assessed to enable 40 percent more processing capability per MHz than the nearest DSP competition. A high-performance internal RISC-based QUICC Engine subsystem supports multiple networking protocols to guarantee reliable data transport

over packet networks while significantly offloading processing from the DSP cores.

The MSC8254 embeds a substantial amount of internal memory to support a variety of advanced, high-speed interface types, including two Serial RapidIO® interfaces, two Gigabit Ethernet interfaces for network communications, a PCI Express® interface, two DDR controllers for a high speed, industry standard memory interface and four multi-channel TDM interfaces.

The MSC8254 allows a high degree of scalability through pin compatibility with all MSC825x and MSC815x DSP devices.

MSC8254 Block Diagram

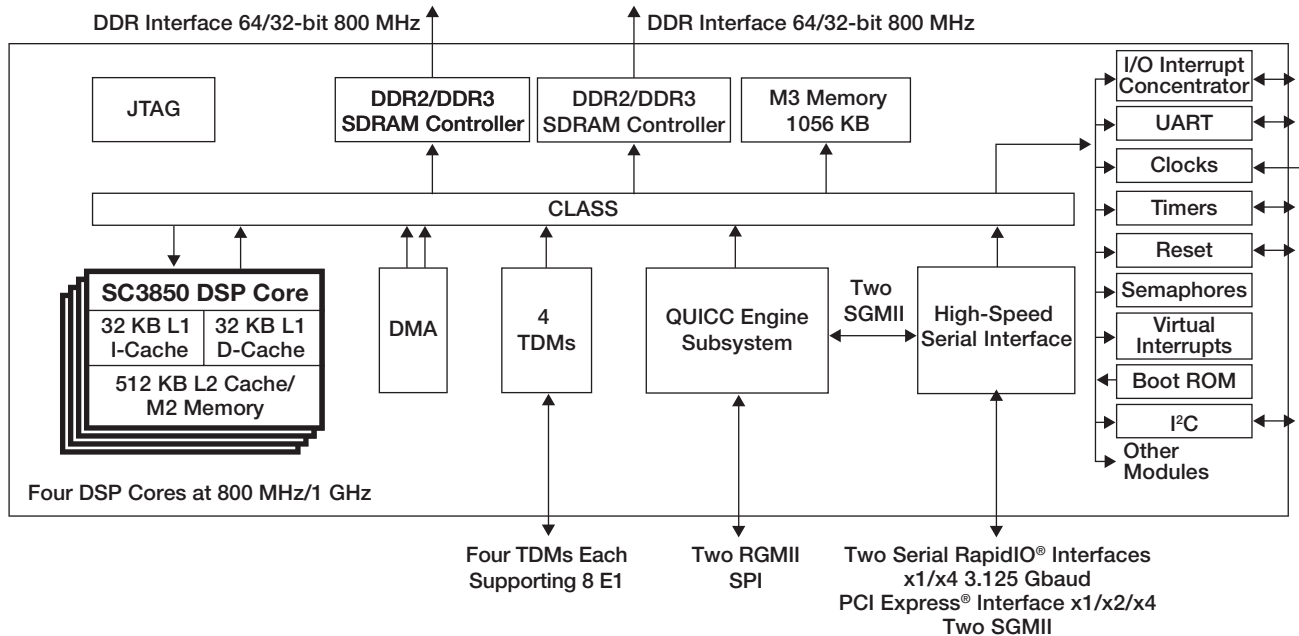

Features and Benefits

- Four StarCore DSP SC3850 core subsystems operating at up to 1 GHz/8000 MMACS per core and up to 32000 MMACS per device
 - Two master buses for data transfers from/to the system memory at a total throughput up to 50 Gbps
 - High-speed, high-bandwidth CLASS fabric arbitrates between the DSP cores and other CLASS masters to M2 memory, M3 memory, DDR controllers and the configuration registers
 - Two DDR controllers with up to 400 MHz clock (800 MHz data) rate and 32/64-bit DDR2/3 SDRAM data bus. Supports SODIMMs and up to 2 GB per controller
 - 32-channel DMA controller
 - Dual RISC core QUICC Engine subsystem operating at up to 500 MHz provides parallel packet processing independent of the DSP cores
- Supports:
- Two Gigabit Ethernet controllers supporting RGMII or SGMII
 - SPI

- HSSI that supports two x4 SerDes ports, including:
 - Two Serial RapidIO interfaces supporting x1/x4 operation up to 3.125 Gbaud
 - One PCI Express interface that supports x1/x2/x4 operation
 - Multiplexing capability for RapidIO, PCI Express and SGMII signals through the two SerDes ports
- Four TDM interfaces
- UART and I²C interfaces
- Eight software watchdog timers
- Sixteen 16-bit timers
- Two 32-bit general purpose timers per core for RTOS support
- I/O interrupt concentrator and virtual interrupt support
- Eight hardware semaphores
- 32 GPIO ports multiplexed with interface signals and IRQ inputs
- Boot options: Ethernet, Serial RapidIO, I²C and SPI
- Three input clocks and five PLLs
- JTAG Test Access Port (TAP) and boundary scan architecture designed to comply with IEEE 1149.1™ standard for profiling and performance monitoring support
- Reduced power dissipation with wait, stop and power down low-power standby modes
- Optimized power management circuitry
- Technology: CMOS 45 nm SOI technology in 29 x 29 mm, 783 ball, FC-PBGA package

Development Support

Freescale supplies a complete set of CodeWarrior DSP development tools for the MSC8254 device. The tools provide easier, more robust ways for designers to develop optimized DSP and gives designers everything they need to exploit the advanced capabilities of the MSC8254 architecture.

Support tools include:

- Eclipse-based integrated development environment (IDE)
- C and C++ compiler with in-line assembly
- Librarian
- Multicore debugger
- Royalty-free RTOS
- Software simulator
- Profiler
- High-speed run control
- Host platform support
- MSC8156ADS development board
- MSC8156EVM evaluation module

Contact your local sales office or representative for availability.



Learn More:

For current information about Freescale products and documentation, please visit freescale.com/DSP.