

FEATURES

3.0 μ s Acquisition Time to $\pm 0.01\%$ max
Low Droop Rate: 1.0 mV/ms max
Sample/Hold Offset Step: 3 mV max
Aperture Jitter: 0.5 ns
Extended Temperature Range: -55°C to $+125^{\circ}\text{C}$
Internal Hold Capacitor
Internal Application Resistors
 ± 12 V or ± 15 V Operation
Available in Surface Mount

APPLICATIONS

Data Acquisition Systems
Data Distribution Systems
Analog Delay & Storage
Peak Amplitude Measurements
MIL-STD-883 Compliant Versions Available

PRODUCT DESCRIPTION

The AD585 is a complete monolithic sample-and-hold circuit consisting of a high performance operational amplifier in series with an ultralow leakage analog switch and a FET input integrating amplifier. An internal holding capacitor and matched applications resistors have been provided for high precision and applications flexibility.

The performance of the AD585 makes it ideal for high speed 10- and 12-bit data acquisition systems, where fast acquisition time, low sample-to-hold offset, and low droop are critical. The AD585 can acquire a signal to $\pm 0.01\%$ in 3 μ s maximum, and then hold that signal with a maximum sample-to-hold offset of 3 mV and less than 1 mV/ms droop, using the on-chip hold capacitor. If lower droop is required, it is possible to add a larger external hold capacitor.

The high speed analog switch used in the AD585 exhibits aperture jitter of 0.5 ns, enabling the device to sample full scale (20 V peak-to-peak) signals at frequencies up to 78 kHz with 12-bit precision.

The AD585 can be used with any user-defined feedback network to provide any desired gain in the sample mode. On-chip precision thin-film resistors can be used to provide gains of +1, -1, or +2. Output impedance in the hold mode is sufficiently low to maintain an accurate output signal even when driving the dynamic load presented by a successive-approximation A/D converter. However, the output is protected against damage from accidental short circuits.

The control signal for the HOLD command can be either active high or active low. The differential HOLD signal is compatible with all logic families, if a suitable reference level is provided. An on-chip TTL reference level is provided for TTL compatibility.

REV. A

Information furnished by Analog Devices is believed to be accurate and reliable. However, no responsibility is assumed by Analog Devices for its use, nor for any infringements of patents or other rights of third parties which may result from its use. No license is granted by implication or otherwise under any patent or patent rights of Analog Devices.

FUNCTIONAL BLOCK DIAGRAM

DIP

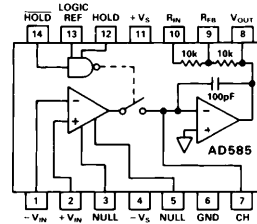

LCC/PLCC Package

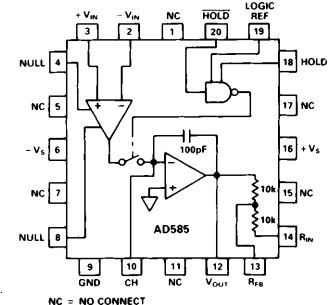

The AD585 is available in three performance grades. The JP grade is specified for the 0°C to $+70^{\circ}\text{C}$ commercial temperature range and packaged in a 20-pin PLCC. The AQ grade is specified for the -25°C to $+85^{\circ}\text{C}$ industrial temperature range and is packaged in a 14-pin cerdip. The SQ and SE grades are specified for the -55°C to $+125^{\circ}\text{C}$ military temperature range and are packaged in a 14-pin cerdip and 20-pin LCC.

PRODUCT HIGHLIGHTS

1. The fast acquisition time (3 μ s) and low aperture jitter (0.5 ns) make it the first choice for very high speed data acquisition systems.
2. The droop rate is only 1.0 mV/ms so that it may be used in slower high accuracy systems without the loss of accuracy.
3. The low charge transfer of the analog switch keeps sample-to-hold offset below 3 mV with the on-chip 100 pF hold capacitor, eliminating the trade-off between acquisition time and S/H offset required with other SHAs.
4. The AD585 has internal pretrimmed application resistors for applications versatility.
5. The AD585 is complete with an internal hold capacitor for ease of use. Capacitance can be added externally to reduce the droop rate when long hold times and high accuracy are required.
6. The AD585 is recommended for use with 10- and 12-bit successive-approximation A/D converters such as AD573, AD574A, AD674A, AD7572 and AD7672.
7. The AD585 is available in versions compliant with MIL-STD-883. Refer to the Analog Devices Military Products Databook or current AD585/883B data sheet for detailed specifications.

AD585—SPECIFICATIONS (typical @ +25°C and $V_S = \pm 12\text{ V}$ or $\pm 15\text{ V}$, and $C_H = \text{Internal}$, $A = +1$, HOLD active unless otherwise noted)

Model	AD585J			AD585A			AD585S			Units
	Min	Typ	Max	Min	Typ	Max	Min	Typ	Max	
SAMPLE/HOLD CHARACTERISTICS										
Acquisition Time, 10 V Step to 0.01%			3			3			3	μs
20 V Step to 0.01%			5			5			5	μs
Aperture Time, 20 V p-p Input, HOLD 0 V		35			35			35		ns
Aperture Jitter, 20 V p-p Input, HOLD 0 V		0.5			0.5			0.5		ns
Settling Time, 20 V p-p Input, HOLD 0 V, to 0.01%		0.5			0.5			0.5		μs
Droop Rate			1			1			1	mV/ms
Droop Rate T_{MIN} to T_{MAX}		Doubles Every 10°C			Double Every 10°C			Doubles Every 10°C		
Charge Transfer			0.3			0.3			0.3	pC
Sample-to-Hold Offset	-3		3	-3		3	-3		3	mV
Feedthrough 20 V p-p, 10 kHz Input		0.5			0.5			0.5		mV
TRANSFER CHARACTERISTICS¹										
Open Loop Gain $V_{\text{OUT}} = 20\text{ V p-p}$, $R_L = 2\text{ k}$		200,000			200,000			200,000		V/V
Application Resistor Mismatch Common-Mode Rejection $V_{\text{CM}} = \pm 10\text{ V}$	80		0.3	80		0.3	80		0.3	%
Small Signal Gain Bandwidth $V_{\text{OUT}} = 100\text{ mV p-p}$		2.0			2.0			2.0		MHz
Full Power Bandwidth $V_{\text{OUT}} = 20\text{ V p-p}$		160			160			160		kHz
Slew Rate $V_{\text{OUT}} = 20\text{ V p-p}$		10			10			10		V/ μs
Output Resistance (Sample Mode) $I_{\text{OUT}} = \pm 10\text{ mA}$			0.05			0.05			0.05	Ω
Output Short Circuit Current		50			50			50		mA
Output Short Circuit Duration		Indefinite			Indefinite			Indefinite		
ANALOG INPUT CHARACTERISTICS										
Offset Voltage			5			2			2	mV
Offset Voltage, T_{MIN} to T_{MAX}			6			3			3	mV
Bias Current			2			2			2	nA
Bias Current, T_{MIN} to T_{MAX}			5			5		20	50²	nA
Input Capacitance, $f = 1\text{ MHz}$		10			10			10		pF
Input Resistance, Sample or Hold 20 V p-p Input, $A = +1$		10^{12}			10^{12}			10^{12}		Ω
DIGITAL INPUT CHARACTERISTICS										
TTL Reference Output	1.2	1.4	1.6	1.2	1.4	1.6	1.2	1.4	1.6	V
Logic Input High Voltage T_{MIN} to T_{MAX}		2.0			2.0			2.0		V
Logic Input Low Voltage T_{MIN} to T_{MAX}			0.8			0.8			0.7	V
Logic Input Current (Either Input)			50			50			50	μA
POWER SUPPLY CHARACTERISTICS										
Operating Voltage Range	+5, -10.8		± 18	+5, -10.8		± 18	+5, -10.8		± 18	V
Supply Current, $R_L = \infty$	6		10	6		10	6		10	mA
Power Supply Rejection, Sample Mode	70			70			70			dB
TEMPERATURE RANGE										
Specified Performance	0		+70	-25		+85	-55		+125	$^\circ\text{C}$
PACKAGE OPTIONS^{3, 4}										
Cerdip (Q-14)				AD585AQ			AD585SQ			
LCC (E-20A)							AD585SE			
PLCC (P-20A)		AD585JP								

NOTES

- ¹Maximum input signal is the minimum supply minus a headroom voltage of 2.5 V.
²Not tested at -55°C .
³E = Leadless Ceramic Chip Carrier; P = Plastic Leaded Chip Carrier; Q = Cerdip.
⁴For AD585/883B specifications, refer to Analog Devices Military Products Databook.

Specifications subject to change without notice.

Specifications shown in **boldface** are tested on all production units at final electrical test. Results from those tests are used to calculate outgoing quality levels. All min and max specifications are guaranteed, although only those shown in **boldface** are tested on all production units.

ABSOLUTE MAXIMUM RATINGS

Supplies (+V _S , -V _S) ±18 V
Logic Inputs ±V _S
Analog Inputs ±V _S
R _{IN} , R _{FB} Pins ±V _S
Storage Temperature -65°C to +150°C
Lead Temperature (Soldering) 300°C
Output Short Circuit to Ground Indefinite
TTL Logic Reference Short Indefinite
Circuit to Ground Indefinite

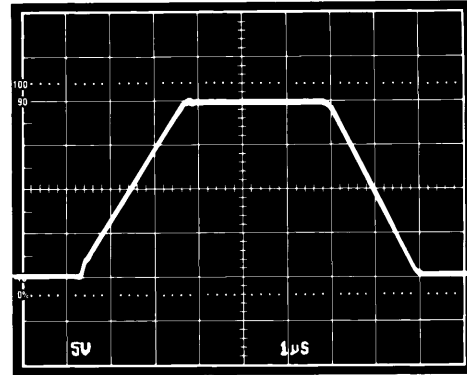

Figure 3. Large Signal Response, Sample Mode

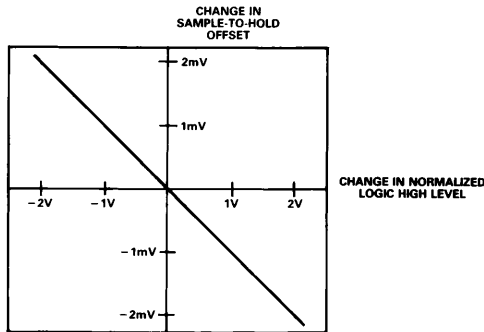

Figure 1. Sample-to-Hold Offset vs. Logic Level (HOLD Active)

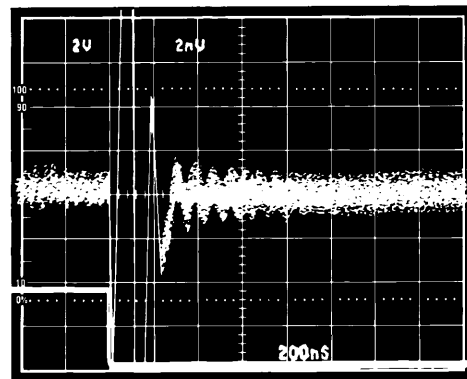

Figure 4. Sample-to-Hold Settling Time (HOLD Active)

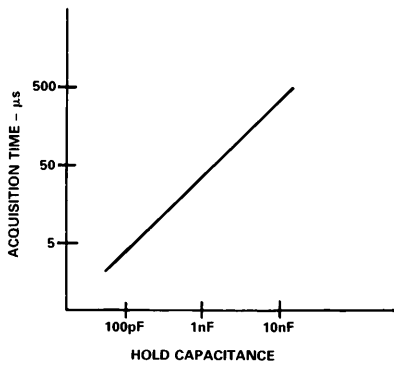

Figure 2. Acquisition Time vs. Hold Capacitance (10 V Step to 0.01%)

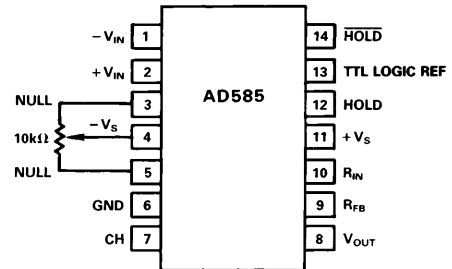

Figure 5. DIP Pin Configuration

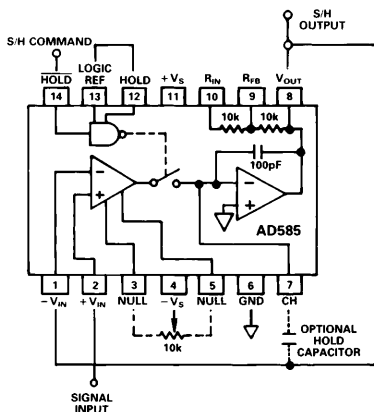

Figure 6. Connection Diagram, Gain = +1, HOLD Active

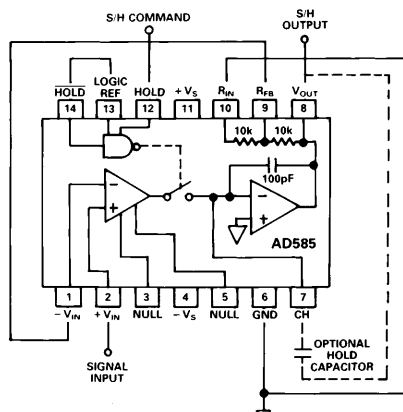

Figure 7. Connection Diagram, Gain = +2, HOLD Active

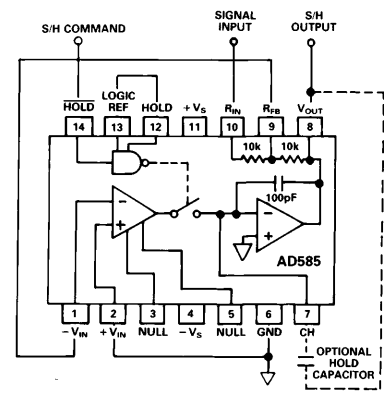

Figure 8. Connection Diagram, Gain = -1, HOLD Active

AD585

SAMPLED DATA SYSTEMS

In sampled data systems there are a number of limiting factors in digitizing high frequency signals accurately. Figure 9 shows pictorially the sample-and-hold errors that are the limiting factors. In the following discussions of error sources the errors will be divided into the following groups: 1. Sample-to-Hold Transition, 2. Hold Mode and 3. Hold-to-Sample Transition.

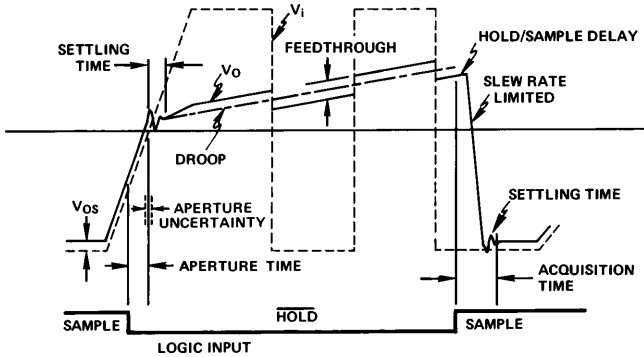

Figure 9. Pictorial Showing Various S/H Characteristics

SAMPLE-TO-HOLD TRANSITION

The aperture delay time is the time required for the sample-and-hold amplifier to switch from sample to hold. Since this is effectively a constant then it may be tuned out. If however, the aperture delay time is not accounted for then errors of the magnitude as shown in Figure 10 will result.

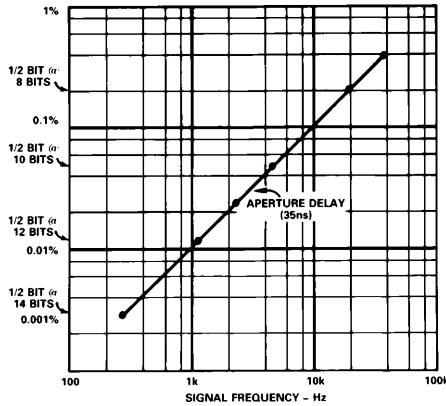

Figure 10. Aperture Delay Error vs. Frequency

To eliminate the aperture delay as an error source the sample-to-hold command may be advanced with respect to the input signal.

Once the aperture delay time has been eliminated as an error source then the aperture jitter which is the variation in aperture delay time from sample-to-sample remains. The aperture jitter is a true error source and must be considered. The aperture jitter is a result of noise within the switching network which modulates the phase of the hold command and is manifested in the variations in the value of the analog input that has been held. The aperture error which results from this jitter is directly related to the dV/dt of the analog input.

The error due to aperture jitter is easily calculated as shown below. The error calculation takes into account the desired accuracy corresponding to the resolution of the N-bit A/D converter.

$$f_{MAX} = \frac{2^{-(N+1)}}{\pi (Aperture\ Jitter)}$$

For an application with a 10-bit A/D converter with a 10 V full scale to a 1/2 LSB error maximum.

$$f_{MAX} = \frac{2^{-(10+1)}}{\pi (0.5 \times 10^{-9})}$$

$$f_{MAX} = 310.8\ kHz.$$

For an application with a 12-bit A/D converter with a 10 V full scale to a 1/2 LSB error maximum:

$$f_{MAX} = \frac{2^{-(12+1)}}{\pi (0.5 \times 10^{-9})}$$

$$f_{MAX} = 77.7\ kHz.$$

Figure 11 shows the entire range of errors induced by aperture jitter with respect to the input signal frequency.

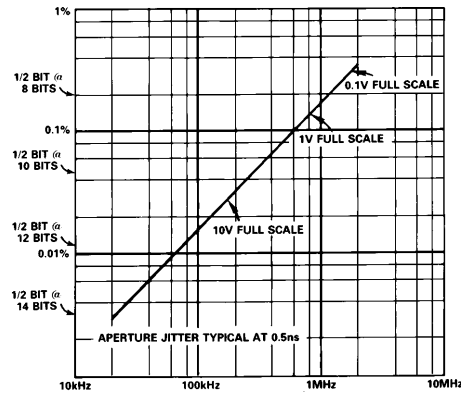

Figure 11. Aperture Jitter Error vs. Frequency

Sample-to-hold offset is caused by the transfer of charge to the holding capacitor via the gate capacitance of the switch when switching into hold. Since the gate capacitance couples the switch control voltage applied to the gate on to the hold capacitor, the resulting sample-to-hold offset is a function of the logic level.

The logic inputs were designed for application flexibility and, therefore, a wide range of logic thresholds. This was achieved by using a differential input stage for \overline{HOLD} and \overline{HOLD} . Figure 1 shows the change in the sample-to-hold offset voltage based upon an independently programmed reference voltage. Since the input stage is a differential configuration, the offset voltage is a function of the control voltage range around the programmed threshold voltage.

The sample-to-hold offset can be reduced by adding capacitance to the internal 100 pF capacitor and by using \overline{HOLD} instead of \overline{HOLD} . This may be easily accomplished by adding an external capacitor between Pins 7 and 8. The sample-to-hold offset is then governed by the relationship:

$$S/H\ Offset\ (V) = \frac{Charge\ (pC)}{C_H\ Total\ (pF)}$$

For the AD585 in particular it becomes:

$$S/H \text{ Offset (V)} = \frac{0.3 \text{ pC}}{100 \text{ pF} + (C_{EXT})}$$

The addition of an external hold capacitor also affects the acquisition time of the AD585. The change in acquisition time with respect to the C_{EXT} is shown graphically in Figure 2.

HOLD MODE

In the hold mode there are two important specifications that must be considered; feedthrough and the droop rate. Feedthrough errors appear as an attenuated version of the input at the output while in the hold mode. Hold-Mode feedthrough varies with frequency, increasing at higher frequencies. Feedthrough is an important specification when a sample and hold follows an analog multiplexer that switches among many different channels.

Hold-mode droop rate is the change in output voltage per unit of time while in the hold mode. Hold-mode droop originates as leakage from the hold capacitor, of which the major leakage current contributors are switch leakage current and bias current. The rate of voltage change on the capacitor dV/dT is the ratio of the total leakage current I_L to the hold capacitance C_H .

$$\text{Droop Rate} = \frac{dV_{OUT}}{dT} \text{ (Volts/Sec)} = \frac{I_L \text{ (pA)}}{C_H \text{ (pF)}}$$

For the AD585 in particular;

$$\text{Droop Rate} = \frac{100 \text{ pA}}{100 \text{ pF} + (C_{EXT})}$$

Additionally the leakage current doubles for every 10°C increase in temperature above 25°C; therefore, the hold-mode droop rate characteristic will also double in the same fashion. The hold-mode droop rate can be traded-off with acquisition time to provide the best combination of droop error and acquisition time. The tradeoff is easily accomplished by varying the value of C_{EXT} .

Since a sample and hold is used typically in combination with an A/D converter, then the total droop in the output voltage has to be less than 1/2 LSB during the period of a conversion. The maximum allowable signal change on the input of an A/D converter is:

$$\Delta V_{max} = \frac{\text{Full-Scale Voltage}}{2^{(N+1)}}$$

Once the maximum ΔV is determined then the conversion time of the A/D converter (T_{CONV}) is required to calculate the maximum allowable dV/dT .

$$\frac{dV}{dt} \text{ max} = \frac{\Delta V_{max}}{T_{CONV}}$$

The maximum $\frac{dV_{max}}{dT}$ as shown by the previous equation is the limit not only at 25°C but at the maximum expected operating temperature range. Therefore, over the operating temperature range the following criteria must be met ($T_{OPERATION} - 25^\circ\text{C}$) = ΔT .

$$\frac{dV \text{ } 25^\circ\text{C}}{dT} \times 2 \frac{(\Delta T^\circ\text{C})}{10^\circ\text{C}} \leq \frac{dV_{max}}{dT}$$

HOLD-TO-SAMPLE TRANSITION

The Nyquist theorem states that a band-limited signal which is sampled at a rate at least twice the maximum signal frequency can be reconstructed without loss of information. This means that a sampled data system must sample, convert and acquire the next point at a rate at least twice the signal frequency. Thus the maximum input frequency is equal to

$$f_{MAX} = \frac{1}{2(T_{ACQ} + T_{CONV} + T_{AP})}$$

Where T_{ACQ} is the acquisition time of the sample-to-hold amplifier, T_{AP} is the maximum aperture time (small enough to be ignored) and T_{CONV} is the conversion time of the A/D converter.

DATA ACQUISITION SYSTEMS

The fast acquisition time of the AD585 when used with a high speed A/D converter allows accurate digitization of high frequency signals and high throughput rates in multichannel data acquisition systems. The AD585 can be used with a number of different A/D converters to achieve high throughput rates. Figures 12 and 13 show the use of an AD585 with the AD578K and AD574A.

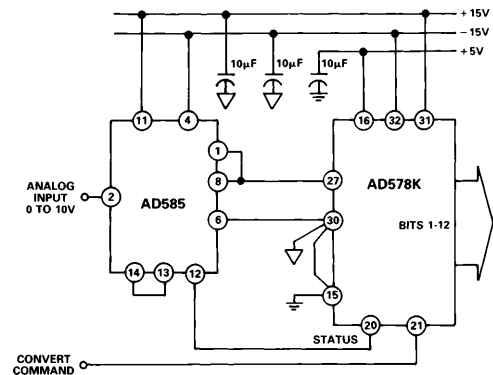

Figure 12. A/D Conversion System, 117.6 kHz Throughput 58.8 kHz max Signal Input

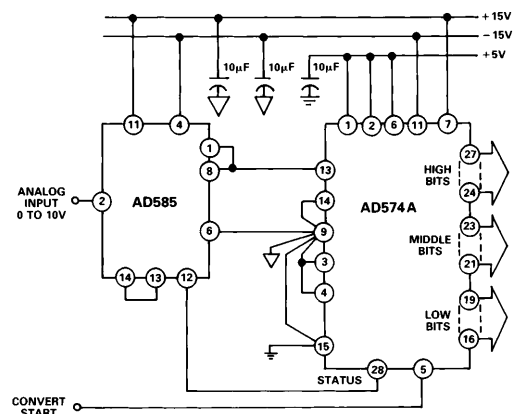

Figure 13. 12-Bit A/D Conversion System, 26.3 kHz Throughput Rate, 13.1 kHz max Signal Input

AD585

LOGIC INPUT

The sample-and-hold logic control was designed for versatile logic interfacing. The HOLD and $\overline{\text{HOLD}}$ inputs may be used with both low and high level CMOS, TTL and ECL logic systems. Logic threshold programmability was achieved by using a differential amplifier as the input stage for the digital inputs. A predictable logic threshold may be programmed by referencing either HOLD or $\overline{\text{HOLD}}$ to the appropriate threshold voltage. For example, if the internal 1.4 V reference is applied to $\overline{\text{HOLD}}$ an input signal to HOLD between +1.8 V and +V_S will place the AD585 in the hold mode. The AD585 will go into the sample mode for this case when the input is between -V_S and +1.0 V. The range of references which may be applied is from (-V_S + 4 V) to (+V_S - 3 V).

OPTIONAL CAPACITOR SELECTION

If an additional capacitor is going to be used in conjunction with the internal 100 pF capacitor it must have a low dielectric absorption. Dielectric absorption is just that; it is the charge absorbed into the dielectric that is not immediately added to or removed from the capacitor when rapidly charged or discharged. The capacitor with dielectric absorption is modeled in Figure 14.

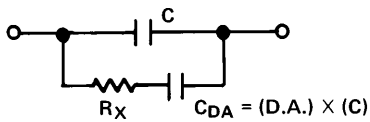

Figure 14. Capacitor Model with Dielectric Absorption

If the capacitor is charged slowly, C_{DA} will eventually charge to the same value as C. But unfortunately, good dielectrics have very high resistances, so while C_{DA} may be small, R_X is large and the time constant R_X C_{DA} typically runs into the millisecond range. In fast charge, fast-discharge situations the effect of dielectric absorption resembles "memory". In a data acquisition system where many channels with widely varying data are being sampled the effect is to have an ever changing offset which appears as a very nonlinear sample-to-hold offset since the differ-

ence between the voltage being measured and the voltage previously measured determines the fraction by which the dielectric absorption figure is multiplied. It is impossible to readily correct for this error source. The only solution is to use a capacitor with dielectric absorption less than the maximum tolerable error. Capacitor types such as polystyrene, polypropylene or Teflon are recommended.

GROUNDING

Many data-acquisition components have two or more ground pins which are not connected together within the device. These "grounds" are usually referred to as the Logic Power Return Analog Common (Analog Power Return), and Analog Signal Ground. These grounds must be tied together at one point, usually at the system power-supply ground. Ideally, a single solid ground would be desirable. However, since current flows through the ground wires and etch stripes of the circuit cards, and since these paths have resistance and inductance, hundreds of millivolts can be generated between the system ground point and the ground pin of the AD585. Separate ground returns should be provided to minimize the current flow in the path from sensitive points to the system ground point. In this way supply currents and logic-gate return currents are not summed into the same return path as analog signals where they would cause measurement errors.

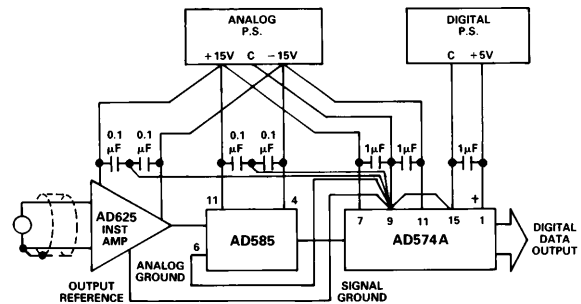
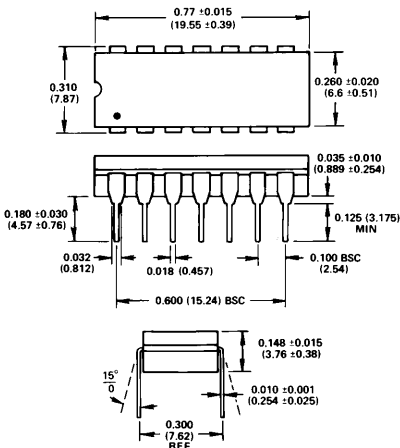

Figure 15. Basic Grounding Practice

OUTLINE DIMENSIONS

Dimensions shown in inches and (mm).

14-Pin Cerdip (Q-14)



20-Terminal LCC (E-20A)

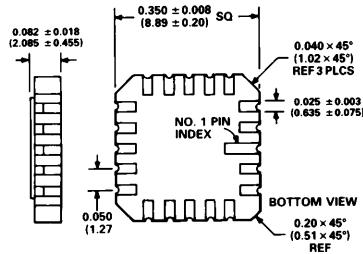

20-Terminal PLCC (P-20A)

