

TRIO-UPS-2G/1AC/24DC/10

Uninterruptible power supply

Data sheet
107432_en_02

© PHOENIX CONTACT 2018-04-19



1 Description

The TRIO-UPS-2G uninterruptible power supply (UPS) with integrated power supply unit is used to ensure that secure DC power for critical electrical loads continues to be supplied in the event of disturbances in the power supply network, e.g. due to mains breakdown or failure. In the event of such a disturbance, the UPS switches to battery operation without interruption so that connected loads continue to be continuously supplied. In this operating mode, the output voltage is directly dependent on the battery voltage. When mains power is restored, the UPS automatically returns to normal operation. The connected loads are again supplied via the power supply network and the battery is charged at the same time. The TRIO-UPS-2G uninterruptible power supply (UPS) is designed specifically for supplying industrial PCs (IPCs).

Features

- Power supply, loading unit and electronic switchover unit in a device
- Wide-range input AC
- Adjustable output voltage in mains operation
- USB interface for configuration and diagnostics
- Adjustable charging parameters for the use of different types of energy storage
- Comprehensive signaling

Technical data (short form)

Input voltage range	100 V AC ... 240 V AC
	110 V DC ... 250 V DC
Nominal output voltage (U_N)	24 V DC
Nominal output current (I_N)	10 A
Buffer period	to 3 h
Residual ripple	< 20 mV
MTBF (IEC 61709, SN 29500)	> 2007013 h (230 V AC, at 25 °C) > 1210518 h (230 V AC, at 40 °C) > 575978 h (230 V AC, at 60 °C)
Maximum power dissipation in no-load condition	< 3 W (for 230 V AC)
Power loss nominal load max.	< 32 W (for 230 V AC)
Ambient temperature (operation)	-25 °C ... 70 °C (> 60 °C Derating: 2.5 %/K)
Ambient temperature (start-up type tested)	-40 °C
Dimensions W/H/D	68 mm / 130 mm / 160 mm
Weight	1.34 kg



Make sure you always use the latest documentation.
It can be downloaded from the product at phoenixcontact.net/products.

2	Table of contents	
1	Description	1
2	Table of contents	2
3	Ordering data	3
4	Technical data	4
5	Safety and installation notes	10
6	Structure	12
7	Mounting and removing	14
8	Device connection	16
9	Device operation	20
10	Method of operation.....	25
11	Battery management	25
12	Signaling.....	26
13	Interface	29
14	Derating.....	29
15	Parallel operation.....	30

3 Ordering data

Description	Type	Order No.	Pcs./Pkt.
Uninterruptible power supply with integrated power supply unit. For lead AGM energy storage with 1.3 Ah to 38 Ah nominal capacity. Input: 1-phase, output: 24 V DC/10 A. Push-in connection technology	TRIO-UPS-2G/1AC/24DC/10	2907161	1
Accessories	Type	Order No.	Pcs./Pkt.
Energy storage device, lead AGM, VRLA technology, 24 V DC, 1.3 Ah, tool-free battery replacement, automatic detection, and communication with QUINT UPS-IQ	UPS-BAT/VRLA/24DC/1.3AH	2320296	1
Energy storage device, lead AGM, VRLA technology, 24 V DC, 3.4 Ah, tool-free battery replacement, automatic detection, and communication with QUINT UPS-IQ	UPS-BAT/VRLA/24DC/3.4AH	2320306	1
Energy storage device, lead AGM, VRLA technology, 24 V DC, 7.2 Ah, tool-free battery replacement, automatic detection, and communication with QUINT UPS-IQ	UPS-BAT/VRLA/24DC/7.2AH	2320319	1
Energy storage device, lead AGM, VRLA technology, 24 V DC, 12 Ah, tool-free battery replacement, automatic detection, and communication with QUINT UPS-IQ	UPS-BAT/VRLA/24DC/12AH	2320322	1
Energy storage device, lead AGM, VRLA technology, 24 V DC, 38 Ah, automatic detection, and communication with QUINT UPS-IQ	UPS-BAT/VRLA/24DC/38AH	2320335	1
Used for communication between an industrial PC and Phoenix Contact devices with USB-Mini-B connection.	MINI-SCREW-USB-DATACABLE	2908217	1
2-piece universal wall adapter for securely mounting the power supply in the event of strong vibrations. The profiles that are screwed onto the side of the power supply are screwed directly onto the mounting surface. The universal wall adapter is attached on the left/right.	UWA 130	2901664	1



Our range of accessories is being continually extended, our current range can be found in the download area.

4 Technical data

Input data	
Input voltage range	100 V AC ... 240 V AC 110 V DC ... 250 V DC
Derating	< 90 V AC (2.5 %/V)
Current consumption (for nominal values) typical	4.5 A (100 V AC) / 2 A (240 V AC) 4 A (110 V DC) / 1.8 A (250 V DC)
Inrush surge current I^2t	< 9 A / < 0.2 A ² s
Input fuse slow-blow, internal	6.3 A
Permissible backup fuse	B10
Crest factor	1.5
Input connection data	
Connection method	Push-in connection
Conductor cross section, solid	0.2 mm ² ... 4 mm ²
Conductor cross section, flexible	0.2 mm ² ... 2.5 mm ²
Conductor cross section AWG/kcmil	24 ... 12
Stripping length	10 mm
Output data	
Derating	> 60 °C (2.5%/K of P _{Out} nom.)
Switch-over time	< 20 ms
Output data (mains operation)	
Nominal output voltage (U _N)	24 V DC
Nominal output current (I _N)	10 A
Output data (battery operation)	
Nominal output voltage (U _N)	U _{BAT} - 0.1 V DC
Nominal output current (I _N)	10 A
Output connection data	
Connection method	Push-in connection
Conductor cross section, solid	0.2 mm ² ... 4 mm ²
Conductor cross section, flexible	0.2 mm ² ... 2.5 mm ²
Conductor cross section AWG/kcmil	24 ... 12
Stripping length	10 mm

Charging process

Battery technology	VRLA
Charge characteristic curve	IU ₀ U
Nominal voltage	24 V DC
Nominal capacity range	1.3 Ah ... 38 Ah
Maximum capacity	140 Ah
Charging voltage maximum	30 V DC
Charge current typical	0.2 A ... 3 A (-25 °C ... 60 °C)
	0 A (60 °C ... 70 °C)

Output connection battery

Connection method	Push-in connection
Conductor cross section, solid	0.2 mm ² ... 10 mm ²
Conductor cross section, flexible	0.2 mm ² ... 6 mm ²
Conductor cross section AWG/kcmil	24 ... 6
Stripping length	15 mm

Status and diagnostic indicators/signal outputs DC OK

Switching output	Transistor output, active
Output voltage	24 V DC
Continuous load current	20 mA
Status display	LED (green)

Status and diagnostic indicators/signal outputs Alarm

Switching output	Transistor output, active
Output voltage	24 V DC
Continuous load current	20 mA
Status display	LED (red)

Status and diagnostic indicators/signal outputs Battery Mode

Switching output	Transistor output, active
Output voltage	24 V DC
Continuous load current	20 mA
Status display	LED (yellow)

Status and diagnostic indicators/signal outputs Ready

Switching output	Transistor output, active
Output voltage	24 V DC
Continuous load current	20 mA

Signal connection data	
Connection method	Push-in connection
Conductor cross section, solid	0.2 mm ² ... 1.5 mm ²
Conductor cross section, flexible	0.2 mm ² ... 1.5 mm ²
Conductor cross section AWG/kcmil	24 ... 16
Stripping length	8 mm
Remote control (Remote)	Digital control input (configurable)
Low signal	Connection to SGnd with < 2.7 kΩ
High signal	Open (> 35 kΩ between remote and SGnd)
Battery-operated start (bat. start)	Digital control input low-active
Low signal	Connection to SGnd with < 2.7 kΩ
High signal	Open (> 200 kΩ between bat. start and SGnd)
Interface	
USB classification	MINI-USB type B
Device combinations	
UPS connection in parallel	yes, with diode module uncoupled
UPS connection in series	no
Energy storage device connection in parallel	yes, max. 5
Power consumption	
Maximum power dissipation in no-load condition	3 W
Power loss nominal load max.	32 W
General data	
Overvoltage category EN 61010-1	II
Efficiency (for nominal values)	($I_{\text{CHARGE}} = 0$; $I_{\text{OUT}} = I_{\text{N}}$) 90 % (120 V AC)
	($I_{\text{CHARGE}} = 0$; $I_{\text{OUT}} = I_{\text{N}}$) 91 % (230 V AC)
MTBF	> 2007013 h (230 V AC, at 25 °C)
Degree of protection	IP20
Protection class	I
Side element version	Aluminum
Hood version	PC
Dimensions W/H/D (normal mounting position/delivered condition)	68 mm / 130 mm / 160 mm
Weight	1.34 kg

Ambient conditions

Ambient temperature (operation)	-25 °C ... 70 °C (> 60 °C Derating: 2.5 %/K)
Ambient temperature (start-up type tested)	-40 °C
Ambient temperature (storage/transport)	-40 °C ... 85 °C
Max. permissible relative humidity (operation)	≤ 93 % (At +25°C, non-condensing)
Installation height	≤ 4000 m (> 2000 m, observe derating)
Degree of pollution	2
Vibration (operation)	< 12 ... 13.2 Hz, amplitude ±1 mm, 13.2 ... 100 Hz, 0.7g in accordance with IEC 60068-2-6
Shock	30g, 18 ms according to IEC 60068-2-27
Climatic class	3K3 (in acc. with EN 60721)

Standards

Standard - safety for equipment for measurement, control, and laboratory use	IEC 61010-1
SELV	IEC 61010 (SELV) / (PELV)
Safe isolation	DIN VDE 0100-410

Approvals

UL approvals	UL Listed UL 61010 UL/C-UL Listed ANSI/ISA-12.12.01 Class I, Division 2, Groups A, B, C
--------------	--



Current approvals/permissions for the product can be found in the download area under phoenixcontact.net/products

Electromagnetic compatibility		
Noise emission according to EN 61000-6-3 (residential and commercial) and EN 61000-6-4 (industrial)		
CE basic standard	Minimum normative requirements	Higher requirements in practice (covered)
Noise emission	EN 61000-6-4 (Class A)	EN 61000-6-3 (Class B)
Conducted noise emission	EN 61000-6-4 (Class A)	EN 61000-6-3 (Class B)
Harmonic currents	EN 61000-3-2 (Class B)	0 kHz ... 2 kHz
Flicker EN 61000-3-3	not required	0 kHz ... 2 kHz
Immunity according to EN 61000-6-1 (residential), EN 61000-6-2 (industrial)		
CE basic standard	Minimum normative requirements	Higher requirements in practice (covered)
Electrostatic discharge EN 61000-4-2		
Housing contact discharge	4 kV (Test Level 2)	6 kV (Test Level 4)
Housing air discharge	8 kV (Test Level 3)	8 kV (Test Level 4)
Comments	none	Criterion B
Electromagnetic HF field EN 61000-4-3		
Frequency range	80 MHz ... 1 GHz	80 MHz ... 6 GHz
Test field strength	10 V/m (Test Level 3)	10 V/m (Test Level 3)
Comments	Criterion B	Criterion A
Fast transients (burst) EN 61000-4-4		
Input	2 kV (Test Level 3 - asymmetrical)	4 kV (Test Level 4 - asymmetrical)
Output	2 kV (Test Level 3 - asymmetrical)	2 kV (Test Level 3 - asymmetrical)
Signal	1 kV (Test Level 3 - asymmetrical)	2 kV (Test Level 4 - asymmetrical)
Comments	Criterion B	Criterion A
Surge voltage load (surge) EN 61000-4-5		
Input	1 kV (Test Level 2 - symmetrical) 2 kV (Test Level 3 - asymmetrical)	2 kV (Test Level 3 - symmetrical) 4 kV (Test Level 4 - asymmetrical)
Output	0.5 kV (Test Level 1 - symmetrical) 0.5 kV (Test Level 1 - asymmetrical)	1 kV (Test Level 1 - symmetrical) 2 kV (Test Level 3 - asymmetrical)
Signal	0.5 kV (Test Level 2 - asymmetrical)	1 kV (Test Level 2 - asymmetrical)
Comments	Criterion B	Criterion A
Conducted interference EN 61000-4-6		
Input/Output/Signal	asymmetrical	asymmetrical

Immunity according to EN 61000-6-1 (residential), EN 61000-6-2 (industrial)

CE basic standard	Minimum normative requirements	Higher requirements in practice (covered)
Frequency range	0.15 MHz ... 80 MHz	0.15 MHz ... 80 MHz
Voltage	10 V (Test Level 3)	10 V (Test Level 3)
Comments	Criterion A	Criterion A

Key

Criterion A Normal operating behavior within the specified limits.

Criterion B Temporary impairment to operational behavior that is corrected by the device itself.



All technical specifications are nominal and refer to a room temperature of 25 °C and 70% relative humidity at 2000 m above sea level.

5 Safety and installation notes

5.1 Symbols used

Instructions and possible hazards are indicated by corresponding symbols in this document.



This is the safety alert symbol. It is used to alert you to potential personal injury hazards. Obey all safety measures that follow this symbol to avoid possible personal injuries.

There are different categories of personal injury that are indicated by a signal word.



WARNING

This indicates a hazardous situation which, if not avoided, could result in death or serious injury.



CAUTION

This indicates a hazardous situation which, if not avoided, could result in minor or moderate injury.

The following symbols are used to indicate potential damage, malfunctions, or more detailed sources of information.



NOTE

This symbol together with the signal word NOTE and the accompanying text alert the reader to a situation which may cause damage or malfunction to the device, hardware/software, or surrounding property.



This symbol and the accompanying text provide the reader with additional information or refer to detailed sources of information.

5.2 Safety and warning notes



WARNING: Danger to life by electric shock!

- Only skilled persons may install, start up, and operate the device.
- Never carry out work when voltage is present.
- Establish connection correctly and ensure protection against electric shock.
- Connect the protective conductor device terminal block ⊕ with ground.
- Cover termination area after installation in order to avoid accidental contact with live parts (e. g., installation in control cabinet).
- This unit receives power from more than one source - Disconnection of AC source and the energy storage is required to de-energize this unit before servicing.
- Keep flames, embers or sparks away from the module.
- When connecting the batteries, observe the polarity and do not short circuit the pole terminals.
- Provide a switch/circuit breaker close to the device at the AC input, DC output and at the battery terminals, which are labeled as the disconnecting device for this device.
- Do not disconnect the fuse and / or battery connection under hazardous location conditions.
- Use copper cables for operating temperatures of >75 °C.



CAUTION: Hot surface

Depending on the ambient temperature and load on the uninterruptible power supply, the housing can become hot.

**NOTE**

- Observe the national safety and accident prevention regulations.
- Assembly and electrical installation must correspond to the state of the art.
- The uninterruptible power supply is a built-in device. The protection class IP20 of the device is meant to be applied in a clean and dry environment.
- The device must be installed in a control cabinet that can be locked and only opened by specialist staff.
- Horizontal mounting position (normal mounting position)
- Observe mechanical and thermal limits.
- Ensure sufficient convection (minimum gap above/below: 50 mm). Housing can become hot.
- Ensure that the primary-side wiring and secondary-side wiring are the correct size and have sufficient fuse protection.
- Refer to the associated table for the connection parameters, such as the necessary stripping length for the wiring with and without ferrule (see section Wire cross sections).
- Protect the device against foreign bodies penetrating it, e.g., paper clips or metal parts.
- To reduce the risk of fire, replace only with same type and rating of fuse.
- To reduce the risk of fire, connect only to a circuit provided with the following maximum branch circuit overcurrent protection in accordance with the National Electrical Code, ANSI/NFPA 70.
- The uninterruptible power supply is maintenance-free. Repairs may only be carried out by the manufacturer. The warranty no longer applies if the housing is opened.
- The uninterruptible power supply may only be used for its intended use.
- Improper use invalidates the device protection.

**More follows**

- Use current-limited source or suitable fuse.
- The switching outputs are active outputs according to SELV. These may only be operated on permitted SELV circuits.
- Keep these instructions in a safe place – this data sheet contains important safety notes which must be observed during installation and maintenance of the UPS devices and batteries.

6 Structure

6.1 Function elements

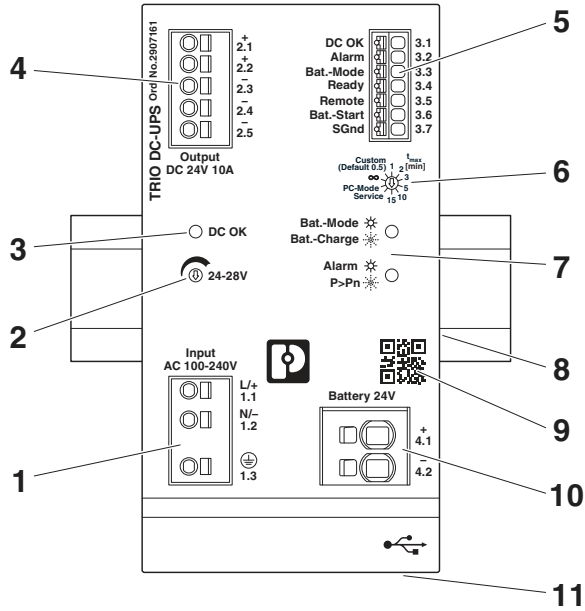

Figure 1 Function elements

Key

No.	Designation
1	Connection terminal blocks input voltage: input L/N/⊕
2	Potentiometer, output voltage: 24 V DC ... 28 V DC
3	LED signaling
4	Connection terminal blocks output voltage: Output DC +/-
5	Connection terminal blocks: Digital input/output (24 V DC / 20 mA)
6	Rotary selector switch
7	Status and diagnostics indicators
8	Universal DIN rail adapter (rear of housing)
9	QR code web link
10	Battery terminal blocks
11	USB interface MINI type B

6.2 Device dimensions and keep-out areas

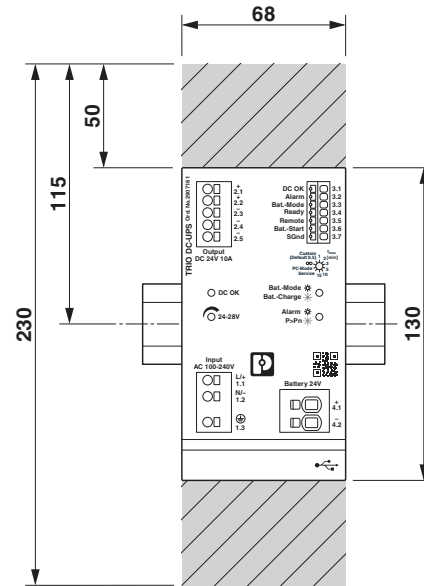

Figure 2 Keep-out areas

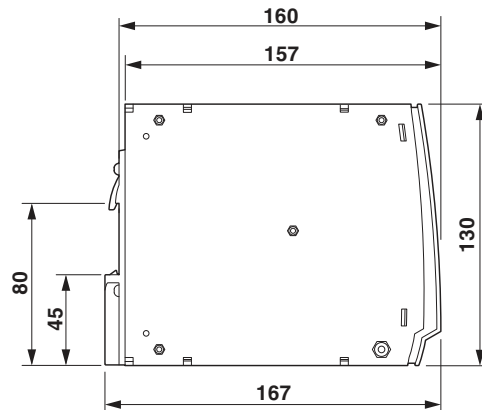

Figure 3 Device dimensions

6.3 Block diagram

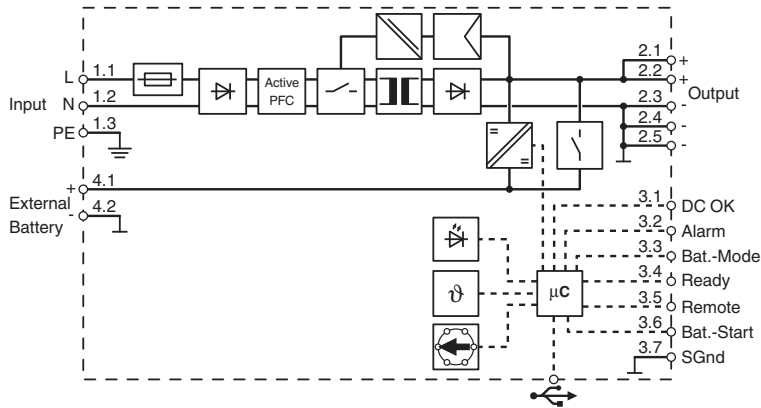

Figure 4 Block diagram

Key

Element	Meaning
	Microprocessor
	LED
	Temperature sensor
	Selector switch
	Fuse
	Decoupling
	Switch
	Electrically isolated signal transmission
	Regulation
	Transformer
	DC/DC converter with electrical isolation

7 Mounting and removing



NOTE

The device must be installed in a control cabinet that can be locked and only opened by specialist staff.

7.1 Convection



NOTE: enable convection

Depending on the ambient temperature and load on the uninterruptible power supply, the housing can become hot.

In order to ensure sufficient convection, we recommend a minimum vertical distance of 50 mm to the other devices.

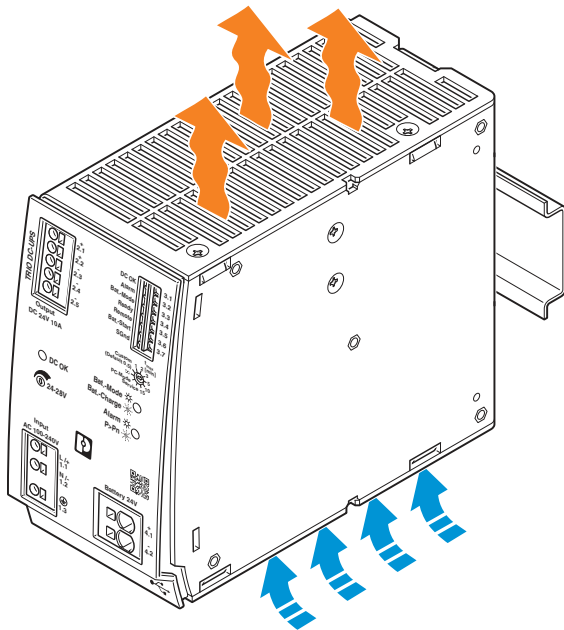

Figure 5 Convection

7.2 Normal mounting position



The device can be snapped onto all DIN rails according to EN 60715 and should only be mounted in the normal mounting position.

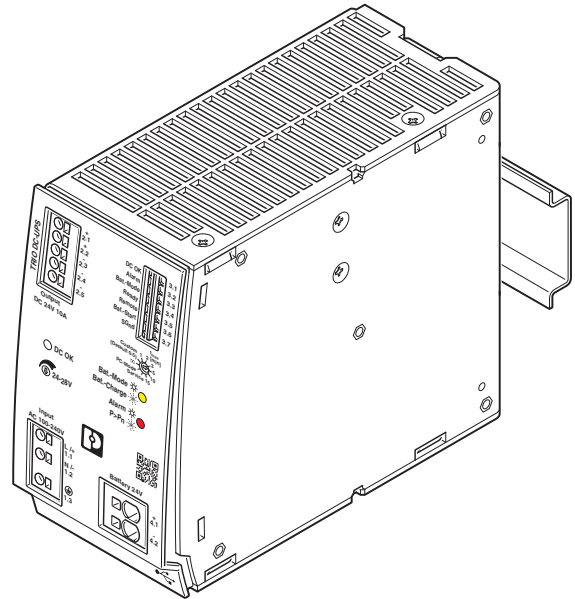

Figure 6 Normal mounting position

7.3 Mounting the uninterruptible power supply

Proceed as follows to mount the device:

1. In the normal mounting position the device is mounted on the DIN rail from above. Make sure that the universal DIN rail adapter is in the correct position behind the DIN rail (A).
2. Then press the device down until the universal DIN rail adapter audibly latches into place (B).
3. Check that the device is securely attached to the DIN rail.

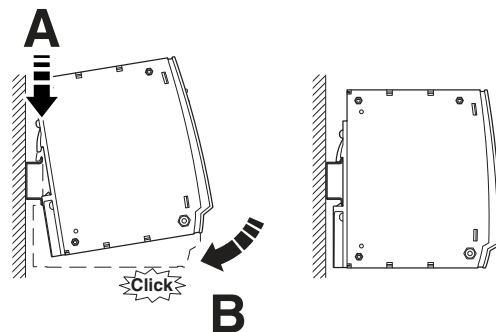

Figure 7 Snapping onto the DIN rail

7.4 Removing the uninterruptible power supply

Proceed as follows to remove the device:

1. Take a suitable screwdriver and insert this into the lock hole on the universal DIN rail adapter (A).
2. Release the lock by lifting the screwdriver (B).
3. Carefully swivel the device forward (C) so that the lock slides back into the starting position.
4. Then separate the device from the DIN rail (D).

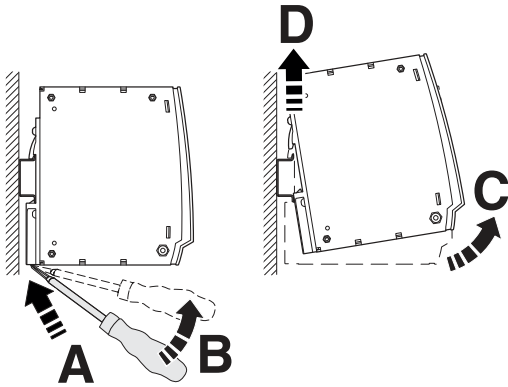

Figure 8 Removing from the DIN rail

7.5 Rotated mounting position (270° Y-axis)

For rotated installation, use the existing universal DIN rail adapter and the Torx screws available.



The maximum tightening torque of the Torx screw (Torx® T10) is 0.7 Nm.

To mount the uninterruptible power supply in a rotated position, fasten the universal DIN rail adapter to the left side of the housing as follows:

1. Remove the screws for the factory-installed universal DIN rail adapter using a suitable screwdriver (Torx 10).
2. Remove the universal DIN rail adapter from the rear of the uninterruptible power supply.
3. Position the universal DIN rail adapter so that the mounting holes match the hole pattern on the left side of the housing.
4. Insert the Torx screws into the appropriate hole pattern on the universal DIN rail adapter so that the necessary drill holes on the device can be accessed.
5. Screw the universal DIN rail adapter onto the device.

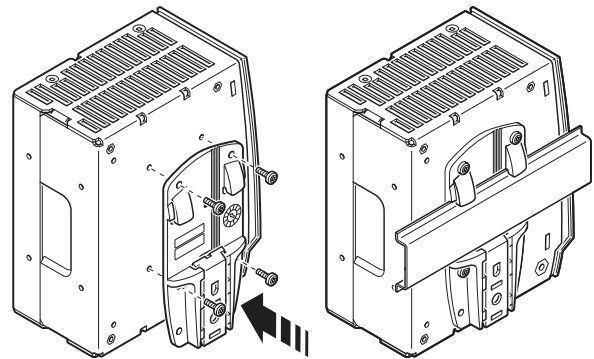

Figure 9 Mounting the universal DIN rail adapter

7.6 Wall mounting

The UWA 130 universal wall adapter (Order No. 2901664) is used to attach the uninterruptible power supply directly to the mounting surface.

The use of the universal wall adapter is recommended under extreme ambient conditions, e.g., strong vibrations. Thanks to the tight screw connection between the uninterruptible power supply and the universal wall adapter or the actual mounting surface, an extremely high level of mechanical stability is ensured.



The UWA 130 is attached to the uninterruptible power supply by means of the Torx screws of the universal wall adapter.

The maximum tightening torque of the Torx screw (Torx® T10) is 0.7 Nm.

Make sure you use suitable mounting material when attaching to the mounting surface.

7.6.1 Mounting the UWA 130 2-piece universal wall adapter

Proceed as follows to disassemble the universal DIN rail adapter that comes pre-mounted:

1. Remove the screws for the universal DIN rail adapter using a suitable screwdriver (Torx 10).
2. Remove the universal DIN rail adapter from the rear of the uninterruptible power supply.
3. Position the two-piece universal wall adapter on the right and left side of the housing.
4. Insert the Torx screws into the appropriate hole pattern on the universal wall adapter so that the necessary mounting holes of the device can be accessed.
5. Screw the universal wall adapter onto the device.

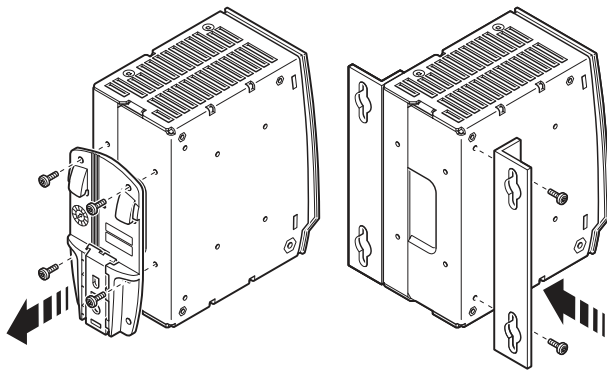

Figure 10 Mounting the UWA 130 universal wall adapter

8 Device connection

8.1 Push-in connection technology

The connection terminal blocks feature front-side Push-in connection technology. The device wiring is performed by plugging in, without tools.

8.1.1 Plug in connecting cable

The wiring is carried out by simply plugging the connecting cable into the contact opening provided. Insert the connecting cable as far as it will go.

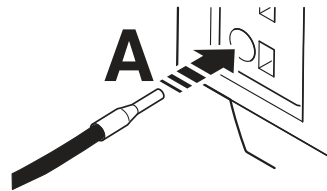

Figure 11 Insert connecting cable (push-in connection technology)

8.1.2 Loosen the connecting cable

To disconnect the wiring, take a suitable screwdriver and insert it into the opening for release. Then carefully pull the connecting cable out of the contact opening.

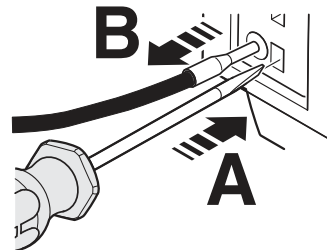

Figure 12 Release connecting cable (push-in connection technology)

8.2 Conductor cross sections

	[mm ²]	[mm ²]	AWG	L [mm]
Input, Output	0,2-4	0,2-2,5	24-12	10
Battery	0,2-10	0,2-6	24-8	15
Signals	0,2-1,5	0,2-1,5	24-16	8

Figure 13 Conductor cross sections

8.3 AC input

The supply voltage is connected via "Input AC" connection terminal blocks.

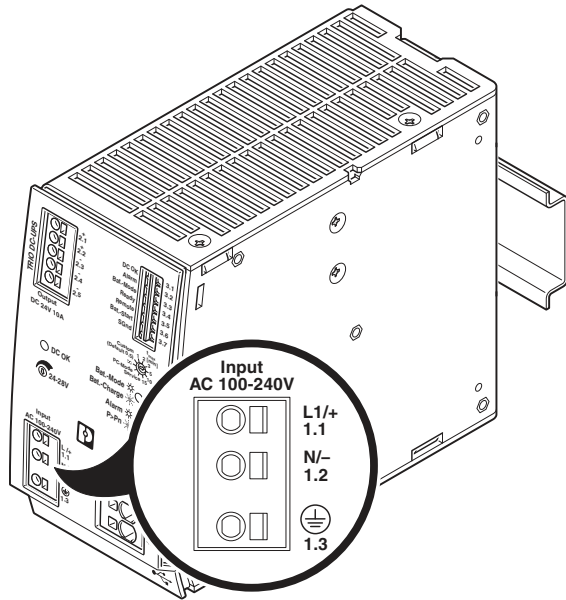

Figure 14 Input voltage connection terminal blocks: input L/N/⊕



If loads must not be supplied in the event of a mains voltage dip or failure, they must be connected directly to the input of the uninterruptible power supply as an unbuffered AC load.

8.3.1 Protection of the primary side

It must be possible to switch the device off using a suitable disconnection device outside the power supply. For example, the primary-side line protection is suitable for this (see technical data).

An internal, approved AC/DC fuse is available as device protection. Additional device protection is not required.



If an internal fuse trips, this is due to a device fault. In this case, the device must be inspected in the factory. Opening the device or repairing it yourself is prohibited.

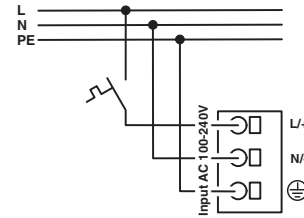

Figure 15 Schematic diagram, switching the input terminals

8.3.2 Mains connection

The uninterruptible power supply can be operated on single-phase AC or DC power grids in accordance with the nominal input voltage. Connection is via the INPUT L+/N-/⊕ connection terminal blocks.

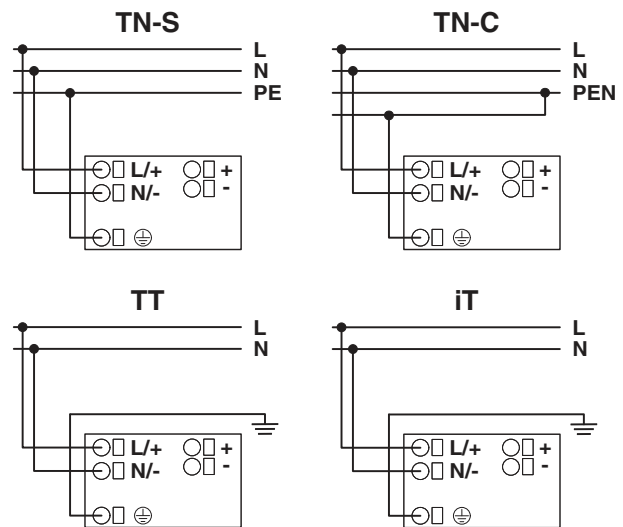

Figure 16 Network types

8.4 DC output

Buffered output voltage is connected via "Output DC" connection terminal blocks.

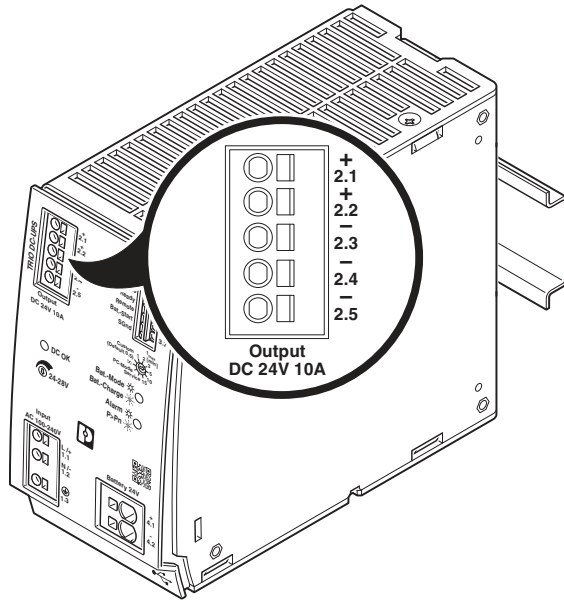

Figure 17 Output voltage connection terminal blocks: Output DC +/-

8.4.1 Protection of the secondary side

The uninterruptible power supply is electronically short-circuit-proof and idling-proof. In the event of an error, the output voltage is limited.

It must be ensured that all output cables are dimensioned appropriately for the maximum output current or have separate protection.

The connecting cables on the secondary side should have large cross sections to keep the voltage drops in the cables as low as possible.

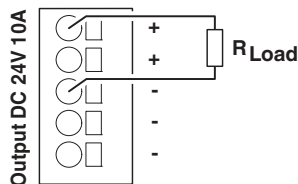

Figure 18 Schematic diagram, switching the output terminals

8.5 Battery 24V

The battery module is connected to the uninterruptible power supply via the "Battery 24V" terminals.

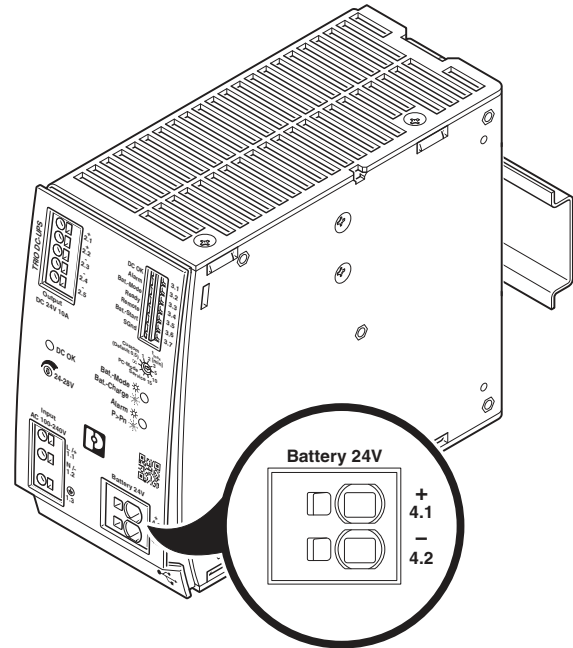

Figure 19 Connection terminal blocks Battery 24V



NOTE: Risk of short circuit

The fuse of the rechargeable battery module must be removed when installing or replacing the module.



The batteries are sealed, maintenance-free lead-AGM batteries that are intended for ambient temperatures from 0°C ... 40°C. The service life is six to nine years at an ambient temperature of 20°C. To ensure immediate availability, all batteries are delivered fully charged. The batteries should be placed in service within no more than nine months at 20°C ... 30°C, or six months at 30°C ... 40°C.

8.6 Connection terminal block signaling

The uninterruptible power supply has the signal outputs:

- DC OK
- Alarm (can be inverted via software)
- Bat. Mode (can be inverted and parameterized via software)
- Ready (can be inverted and parameterized via software)
- Remote
- Bat.-Start
- SGNd

Example:

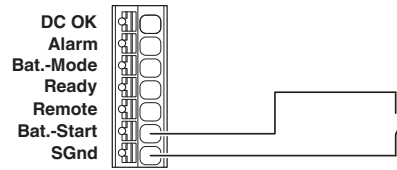

Figure 21 Signal inputs activated

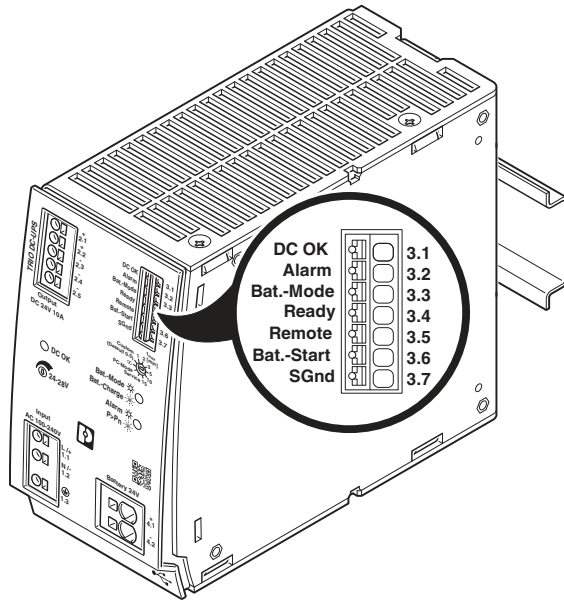

Figure 20 Signal inputs and outputs

The signal outputs are non-isolated (DC output voltage) active outputs. The signal ground (SGNd) or ground connection for the output voltage serves as the reference potential.

The uninterruptible power supply also features the signal inputs:

- Remote (can be inverted via software)
- Bat.-Start

The signal inputs are activated as soon as they are connected to the signal ground.

8.7 Installation of individual components



WARNING

Provide a switch/circuit breaker close to the device at the AC input, DC output and at the battery terminals, which are labeled as the disconnecting device for this device.



NOTE

As so-called wear parts, batteries are not provided with a warranty. Deep discharge and storage beyond the permitted temperature range lead to irreversible damage to batteries.



Follow the documentation for the individual components during installation.

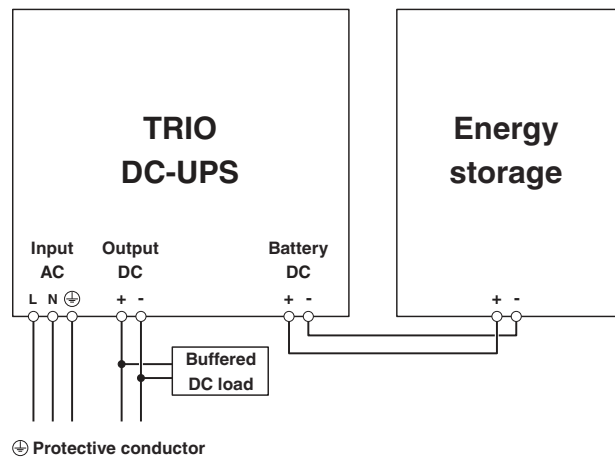

Figure 22 Schematic design



The image is a schematic representation of the design and does not contain all parts. Observe the installation instructions.

9 Device operation

Basic settings for commissioning can be made directly via the rotary selection switch on the device. Advanced settings can be made via the UPS-CONF PC software.



The latest software version is to be found in the product download area.

9.1 Setting the operating mode

You can set the following functions via the rotary selector switch on the front of the device:

- Buffer period
- PC mode
- Service mode



Use a suitable screwdriver to set the rotary selector switch.

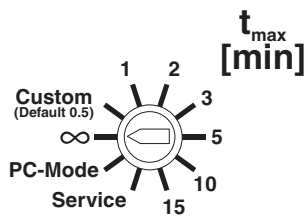

Figure 23 Rotary selector switch

9.1.1 Setting the buffer time

Rotary selector switch setting	Meaning
1, 2, 3, 5, 10, 15	The UPS switches off after the set buffer time.
Custom (default 0.5)	The UPS switches off after the individual buffer time set via UPS-CONF. If a buffer time is not set, the UPS shuts down after 30 seconds.
∞ (unlimited)	Buffering with the total stored energy. An alarm is generated as soon as the voltage of the energy storage falls below 20.4 V (default).

Refer to the following diagram for information on how the device behaves in buffer mode:

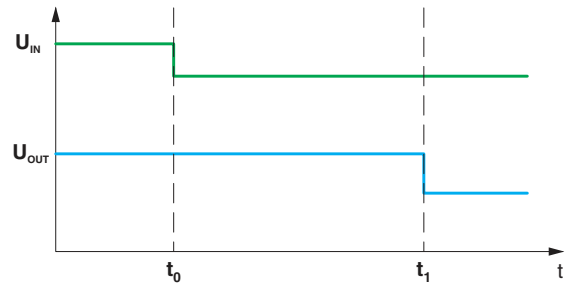

Figure 24

t_0 : mains power failure

t_1 : after the preset buffer time has expired, the output is switched off

Refer to the following diagram for possible buffer times for varying discharge currents.

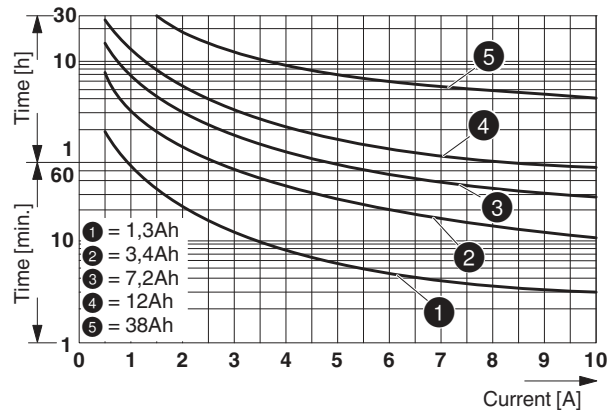

Figure 25 Buffer time/discharge current diagram

9.1.2 PC mode

In PC mode, you can individually parameterize the chronological sequence of the UPS functions via the UPS-CONF configuration software.

To access the PC mode of the UPS, set the rotary selector switch to PC mode.



The following components are required for the PC mode function:
 Data cable MINI-SCREW-USB-DATACABLE (Order No. 2908217)
 Configuration software UPS-CONF (Order No. 2320403)

In the event of a mains failure, one PC can continue to work, perform a controlled shutdown, and restart automatically.

1. Delay time

If the mains supply is not restored during the delay time, the PC is shut down.

2. Program start

After the delay time has expired, it is possible to start a program.

3. PC shutdown

The time required for PC shutdown is set here.

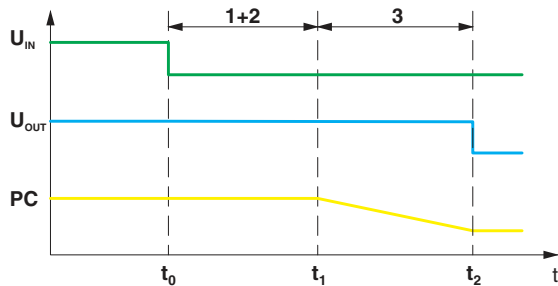

Figure 26

- t_0 : mains power failure
- t_1 : delay time and program runtime have expired, PC will be shut down
- t_2 : the PC has shut down, the output will be switched off

4. PC idle time

Only if the PC is shut down and the mains supply is restored in the meantime is the output voltage interrupted for the reset time and the PC then started automatically.

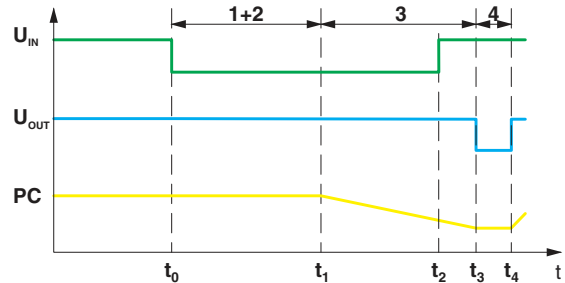

Figure 27

- t_0 : mains power failure
- t_1 : delay time and program runtime have expired, PC will be shut down
- t_2 : mains restored while PC is shutting down
- t_3 : the PC has shut down and the output will be switched off, PC idle time starts
- t_4 : the PC idle time has expired, PC is starting back up



If the Remote contact is opened in PC mode, the preset delay time is skipped in the event of a mains failure.

9.1.3 Service mode

When working in a system, it may be necessary to switch the uninterruptible power supply unit over to service mode.

To access the Service mode of the UPS, set the rotary selector switch to Service.



You can enter the service mode only if input voltage is present. If the supply voltage fails while in service mode, the uninterruptible power supply switches to battery operation with unlimited buffer time. The signaling then corresponds to the signaling for battery operation.



In this operating mode, DC battery connection terminal blocks are deactivated using software. The active signal output is always activated when the unit is switched over to service mode.

Energy storage device replacement



WARNING

When connecting the batteries take note of the polarity.
Do not short circuit the pole terminals.
The batteries are maintenance free and may not be opened.



NOTE

When replacing batteries, always use new batteries from the same production batch.



When storing the battery modules, observe the latest startup date and recharge, if necessary. The batteries may only be recharged in an uninterruptible power supply.

The switch to energy storage is done according to the UPS-BAT/VRLA/24DC/3.4AH example:

1. Set the rotary selector switch to Service.
2. Press the locking lugs on the housing top and open the front cover of the housing.
3. Remove the fuses (see figure: Removing fuse).
4. Remove the cabling of the battery blocks.
5. Remove the batteries.
6. Install the new batteries.
7. Connect the cabling of the battery blocks.
8. Install the fuses (see figure: Inserting fuse).
9. Close the front cover until the locking lugs snap into the top.
10. Secure the housing to prevent it from being opened.
11. Exit Service mode.
12. Set the buffer time or PC mode.

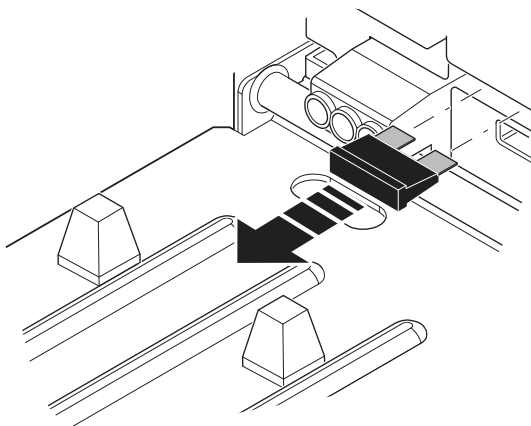

Figure 28 Remove fuse

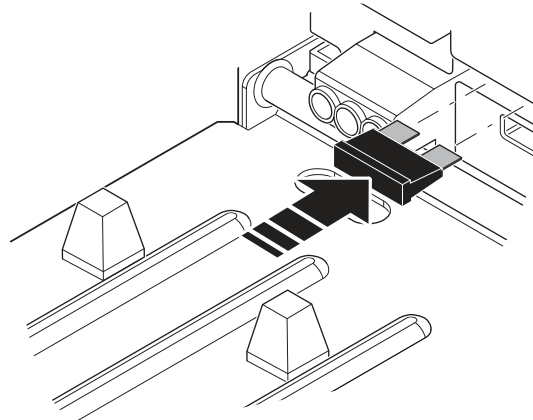

Figure 29 Insert fuse

Notes on disposal



Do not dispose of the UPS and battery modules in household waste! They should be disposed of according to the currently applicable national regulations.



You can return used batteries and accumulators to Phoenix Contact or the manufacturer.

9.2 Remote

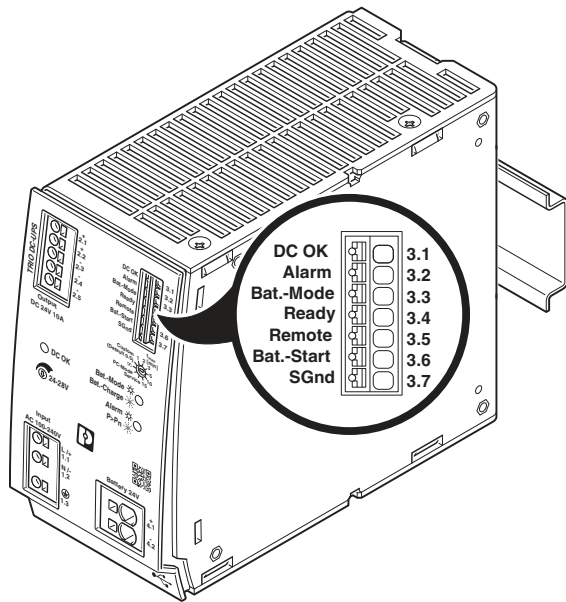

Figure 30 Signal inputs and outputs

You can use the Remote signal terminal to:

1. Suppress and exit battery operation.
2. Perform controlled shutdown of the PC in battery operation.

To perform these steps, you must connect the Remote signal terminal to the SGnd signal terminal.

This sets the UPS internal Remote signal.

1. Remote deactivates battery operation

You can deactivate battery operation using this function. This function is always active when a buffer time has been preset.

This function is the default setting in PC mode.

In mains operation, the Remote signal is indicated by the flashing green LED (see Signaling section).

In the event of mains failure, battery operation is not started.

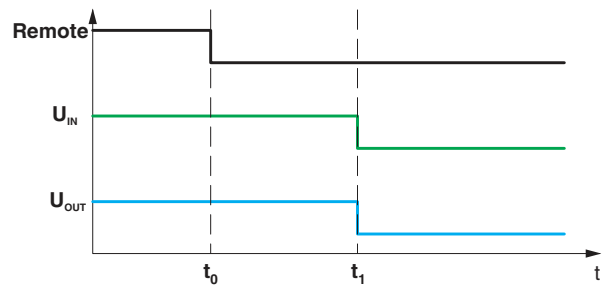

Figure 31

t_0 : remote signal is set in mains operation

t_1 : no input voltage, output will be switched off

If the Remote signal is set in battery operation, battery operation is exited immediately. The UPS output is switched off. This procedure cannot be reversed. The UPS is only activated once the input voltage is applied.

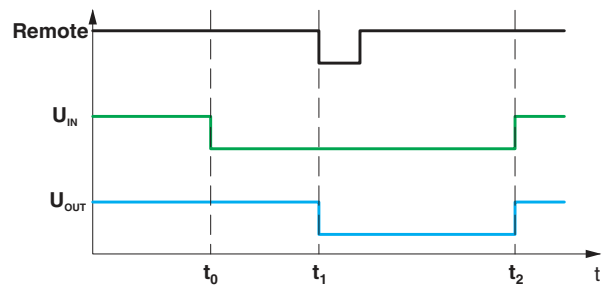

Figure 32

t_0 : no input voltage

t_1 : remote signal is set in battery operation, output will be switched off

t_2 : input voltage restored, output will be switched on

2. Remote starts immediate PC shutdown only in battery operation

You can perform immediate shutdown of the PC when battery operation is entered via the UPS-CONF configuration software.

This setting only applies in PC mode.

The Remote signal is indicated by the flashing green LED (see Signaling section).

If the Remote signal is set in mains operation, the PC is shut down when battery operation is entered. The delay time under Item 1 is skipped (see section PC mode).

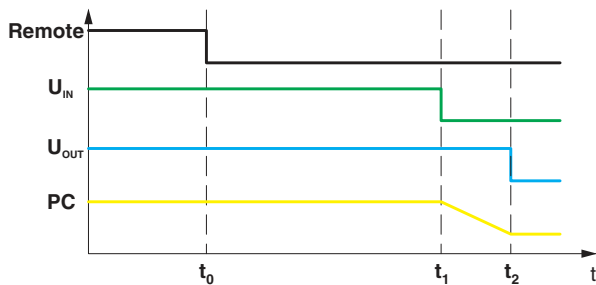

Figure 33

t_0 : remote signal is set in mains operation

t_1 : no input voltage, PC shutdown begins immediately

t_2 : the PC has shut down, the output will be switched off



Once the PC has shut down in battery operation, the uninterruptible power supply output is switched off. This procedure cannot be reversed. The uninterruptible power supply is not activated until the input voltage is applied.

9.3 Battery start (Bat.-Start)

You can use the Bat.-Start signal terminal to start the UPS without supply voltage on the input side and create an autonomous supply for the load. To do this, you must connect the Bat.-Start signal terminal to the SGnd signal terminal.

The output voltage provided at the load matches the battery voltage.

The maximum duration of the autonomous supply for the load depends on the charging state of the battery.

The signaling corresponds to the signaling for battery operation (see Signaling section).

To exit autonomous operation, you must disconnect the Bat.-Start signal terminal and the SGnd signal terminal.

If PC Mode operating mode is set, then in this case the PC shuts down immediately (see section Remote starts immediate PC shutdown).

9.4 Software configuration

You can request the current device status via the UPS-CONF software. Furthermore, you can change the settings of certain parameters within a defined value range and reset them to the default settings. Please refer to the respective setting options in the following table:

Parameter	Value range	Default setting
Field of application		/
Connected nominal battery capacity	1.3 ... 140 Ah	7,2 Ah
Initial charging current	0.2 ... 3 A	2 A
Compensation end-of-charge voltage	25 ... 30 V DC	28 V DC
Conservation end-of-charge voltage	25 ... 30 V DC	27.6 V DC
Temperature compensation	-200 ... 0 mV/K	-42 mV/K
Signaling threshold of alarm - maximum charging time exceeded	4 ... 200 h	18 h
End-of-discharge voltage	18 ... 24 V DC	19.2 V DC
Signaling threshold of alarm - battery voltage	18 ... 30 V	20.4 V DC
Continuous signaling after battery discharge	0 ... 600 min	10 min
Continuous signaling after timeout	0 ... 600 min	10 min

In addition to parameter setting options, the software also features setting options for signaling, for communication parameters, and for the remote contact.

10 Method of operation

10.1 Output characteristic curve

The uninterruptible power supply works with a dynamic power reserve – the dynamic boost – in accordance with the U/I characteristic curve shown in the illustration. In the event of a secondary-side short circuit or overload, the output current is limited to $1.5 \times I_N$. The device does not switch off, but instead continues to supply the output current. The secondary voltage is then reduced until the short circuit is eliminated. The U/I characteristic curve with the dynamic power reserve makes it possible to provide high switch-on currents of capacitive loads or inductive loads reliably.

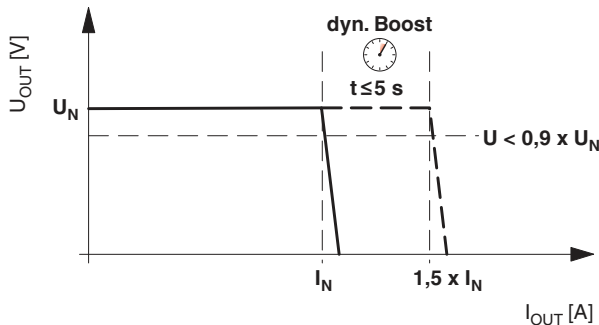

Figure 34 U/I characteristic curve with dynamic load reserve

- $U_N = 24 \text{ V}$
- $I_N = 10 \text{ A}$
- $I_{\text{dyn. BOOST}} = 15 \text{ A}$
- $P_N = 240 \text{ W}$
- $P_{\text{dyn. BOOST}} = 360 \text{ W}$

10.2 Dynamic Boost

The following example is used to explain how the uninterruptible power supply dynamic boost functions.

Example:

The uninterruptible power supply supplies a connected base load of 80% until time point t_1 (see illustration, schematic diagram of the dynamic boost behavior). If an additional load is activated while the device is in operation, the dynamic boost is requested for the period of time t_1 to t_2 . The uninterruptible power supply provides the maximum dynamic power reserve of an additional 70% ($\Delta P_{\text{dyn. boost}} = 1.5 \times I_N \times U_N - P_{\text{initial load}}$).

As such, the requested overall total power corresponds to 150% of the nominal power. This power can be accessed for at least 5 s in the event that the output voltage remains the same. On reaching time point t_2 , the dynamic boost is once more returned to the output value of the base load for thermal offloading of the uninterruptible power supply. In this case, the base load amounts to the same value of 80%, as it

was prior to time point t_1 . If the request to supply the load still exists when the time intervals t_2 to t_3 have expired (at least $4 \times t_{\text{Boost}}$), a new cyclical switching of the dynamic power reserve occurs, to a total of 70%.

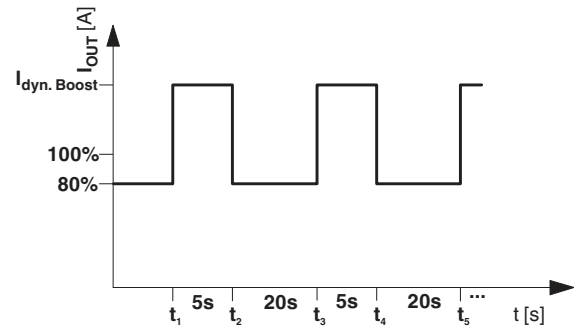

Figure 35 Schematic diagram of dynamic boost behavior



The permanent output power P_N is limited at an ambient temperature of 60 °C. Observe all the maximum output powers for the respective operating conditions.

11 Battery management

The TRIO-UPS battery management is divided into two tests that are performed cyclically during normal operation.

11.1 Battery presence test

The battery presence test is used to detect whether a correctly installed battery is present. If this is not the case, the test fails and the green and red LED control lamps come on and stay on.

11.2 Quality check of battery

The battery quality test is a life cycle test.

When the maximum charging time has been exceeded, conclusions can be drawn regarding the maximum service life of the battery, for example. If an event arises, the green and red LED control lamps come on and stay on.

11.3 Battery charging

The device has a maximum charging current of 3 A.

Refer to the following table for the times required to recharge a fully discharged battery.

Order No.	Battery	Recharging times [hr.], [T _A = 25 °C, I _{cmax}]
2320296	UPS-BAT/VRLA/24DC/ 1.3AH	04:00
2320306	UPS-BAT/VRLA/24DC/3.4AH	05:00
2320319	UPS-BAT/VRLA/24DC/7.2AH	05:30
2320322	UPS-BAT/VRLA/24DC/12AH	07:00
2320335	UPS-BAT/VRLA/24DC/38AH	15:30



Note: The actual charging times may deviate from the information provided in the table, e.g. due to ambient temperature differences.

You can support the main charging operation by connecting an additional power supply unit to the battery in parallel to the UPS. This can speed up the charging process by as much as 30%. If you use this procedure, note the following:

- The output voltage of the additional power supply unit must be less than the minimum float charge end voltage. When using Phoenix Contact VRLA batteries, they should be set to 26.5 V (measured at the battery connection terminal block, without load)
- The aggregate charging current may not exceed the maximum permissible charging current for the battery
- To prevent any current from flowing back into the power supply unit, install a diode decoupling module

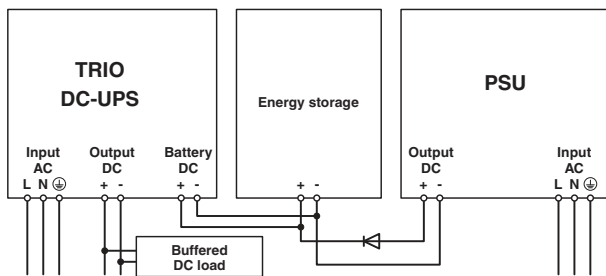

Figure 36 Schematic design - charging the battery with additional power supply unit

12 Signaling

Various LED indicators are available for visual function monitoring of uninterruptible power supplies. Moreover, active signal outputs can be used to forward this data to a higher-level control system.

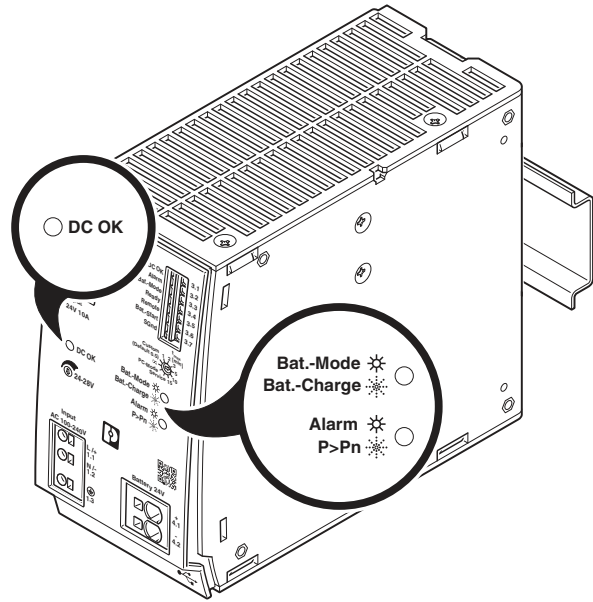

Figure 37 LED indicators

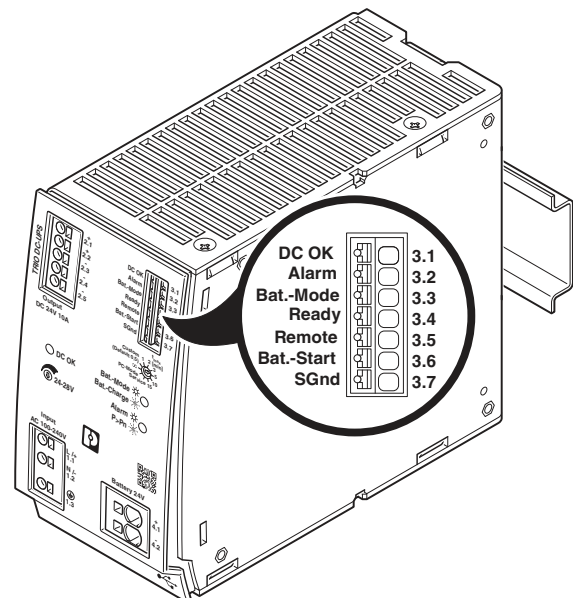

Figure 38 Signal inputs and outputs

12.1 LED indicators and signal outputs

For UPS signaling and the corresponding states, please refer to the table below.

Status LED			Switching output			Note
Green	Yellow	Red	Bat.-Mode	Ready	Alarm (active low)	
○	○	○	low	low	low	Device off
●	●	●	low or high	low	high	Initialization, LED test (~2 sec.) / battery operation, battery failure
●	○	○	low	high	high	Mains operation, battery is fully charged
	☀ D = 50%	○	low	low or high	high	Mains operation, battery charging in process
	●	○	high	low	high	Battery mode
	○	●	low	low	low	Mains operation, battery failure
	○	☀ D = 50%	low	low	low	Mains operation, service mode for battery change
☀ D = 90%	○	○	low	high	high	Mains operation, battery is fully charged, remote contact is shorted to SGnd
	☀ D = 50%	○	high	low	high	Mains operation, battery charging in process, remote contact is shorted to SGnd
	○	●	low	low	low	Mains operation, battery failure, remote contact is shorted to SGnd
	○	☀ D = 50%	low	low	low	Mains operation, service mode for battery change, remote contact is shorted to SGnd
○	○	☀ D = 90%	low	high	high	Overload in mains operation, battery is fully charged
	●	●	high	low	low	Battery operation, battery failure
☀ D = 10%	○	☀ D = 90%	low	low	high	Overload in battery operation
	○	○	low	high	high	Signaling time after cut off in battery mode

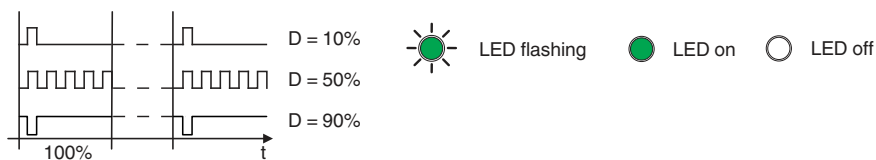

Figure 39 Signal states

12.2 Signal outputs

DC OK

If the output voltage is in the valid range (>90% of the nominal output voltage), the signal output is active.

A digital transistor output is available as a signal contact.

This signal is indicated visually by a green LED.

Alarm

In the event of an alarm, the signal output is active (low level). The signal status can be inverted via the UPS-CONF configuration software.

A digital transistor output is available as a signal contact.

This signal is indicated visually by a red LED.

Possible alarms include:

- Overload
- Battery fault
- Service mode active

Bat.-Mode

If the connected load is being supplied by the battery, the signal output is active. The signal status can be inverted via the UPS-CONF configuration software.

A digital transistor output is available as a signal contact.

This signal is indicated visually by a yellow LED.

You can assign other additional information to this signal output using the UPS-CONF configuration software.

Ready

When the connected energy storage system is fully charged, the signal output is active. The signal status can be inverted via the UPS-CONF configuration software.

A digital transistor output is available as a signal contact.

You can assign other additional information to this signal output using the UPS-CONF configuration software.

12.3 Signal inputs

Remote

You can activate and trigger various functions using the remote signal input. For additional information, please refer to the "Remote device operation" section.

The signal status can be inverted using the UPS-CONF configuration software.



A change made to the remote function using the UPS-CONF configuration software is not applied until a corresponding status change of the remote signal input or device restart has been carried out.

Bat.-Start

You can use the Bat.-Start signal terminal to start the UPS without supply voltage on the input side and create an autonomous supply for the load.

For additional information, please refer to the section "Device operation, battery start".

13 Interface

13.1 USB interface MINI type B

The uninterruptible power supply is equipped with a USB Mini type B interface for data transmission.

A data cable is required for communicating with a PC or a higher-level controller.

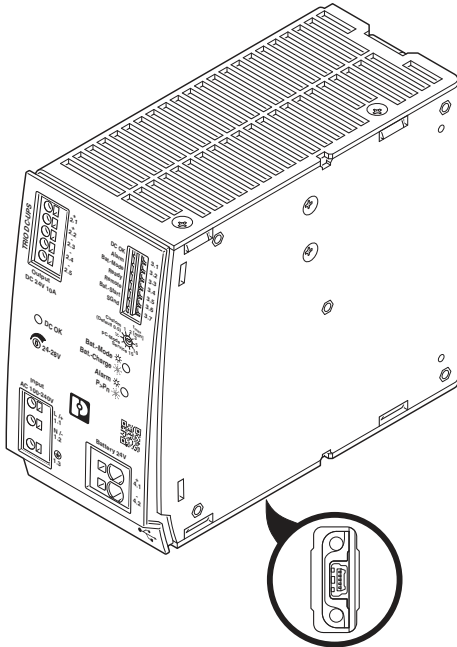

Figure 40 USB interface MINI type B (bottom of device)

13.1.1 MINI-SCREW-USB-DATACABLE

The uninterruptible power supply unit is connected to the USB PC connection with data cable MINI-SCREW-USB-DATACABLE (Order No. 2908217) via USB interface mini type B.

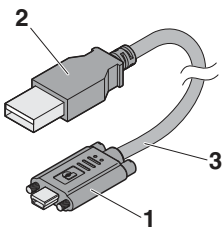

Figure 41 MINI-SCREW-USB-DATACABLE

No.	Designation
1	Mini type B USB connector with screw connection
2	USB plug type A
3	Cable length: 3 m

14 Derating

14.1 Ambient temperature

The device provides both the I_N nominal output current and the $I_{dyn. BOOST}$ dynamic output current at ambient temperatures up to +60 °C. For ambient temperatures above +60 °C, the ambient power must be decreased by 2.5% per Kelvin increase in temperature. For ambient temperatures above +70 °C or in the event of a thermal overload, the device does not switch off. The output power will be decreased by enough to allow device protection. Once the device has cooled down, the output power will be increased again.

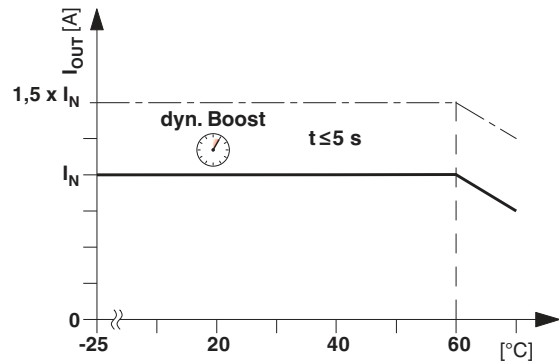

Figure 42 Temperature-dependent derating

14.2 Installation height

The uninterruptible power supply can be operated at an installation height of up to 2000 m without any limitations. Different data applies for installation locations above 2000 m due to the differing air pressure and the reduced convection cooling associated with this.

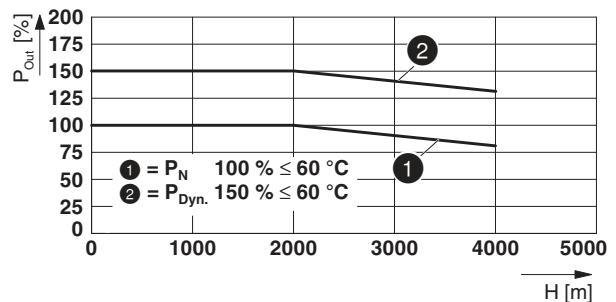

Figure 43 Altitude-dependent derating

15 Parallel operation

Devices of the same type can be connected in parallel to increase both redundancy and power. No further adjustments to the default setting are necessary. To ensure symmetrical current distribution, we recommend that all cable connections from the power supply unit to the busbar are the same length, and have the same conductor cross-section.

Depending on the system, a protective circuit should be installed at each individual device output (e.g. decoupling diode or DC fuse) for parallel connection of more than two devices. This prevents high return currents in the event of a secondary device fault.

15.1 Redundant operation

Redundant circuits are suitable for supplying systems which place particularly high demands on operational reliability. If a fault occurs in the primary circuit of the first uninterruptible power supply unit, the second device automatically takes over the complete power supply without interruption, and vice versa. For this purpose, the power supply units to be connected in parallel must be large enough to ensure that the total current requirements of all loads can be fully met by one power supply unit. External decoupling diodes or ORING modules are required for 100 % redundancy.

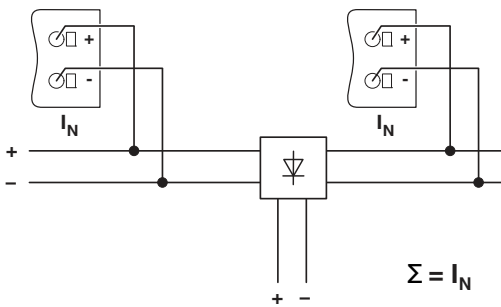

Figure 44 Redundancy operation with decoupling via diode module

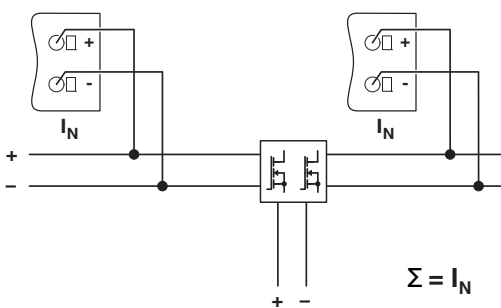

Figure 45 Redundancy operation with decoupling via ORING module

15.2 Increasing power

When two uninterruptible power supplies are connected in parallel, the output current is increased to $2 \times I_N$. Parallel connection for increased power is used when extending existing systems. If the individual uninterruptible power supply does not cover the current consumption of the most powerful load, parallel connection of uninterruptible power supplies is recommended.

i To increase performance, it is imperative that both UPS devices be supplied from the same energy storage system.

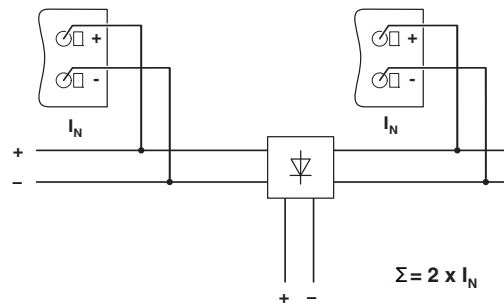

Figure 46 Performance increase with decoupling via diode module

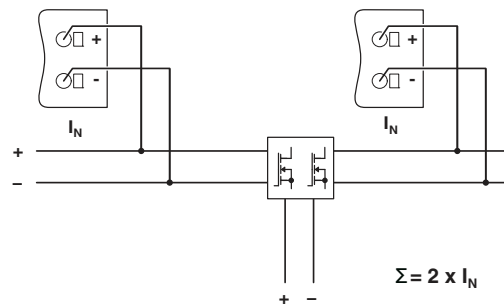

Figure 47 Performance increase with decoupling via ORING module