

This document is the property of and embodies CONFIDENTIAL and PROPRIETARY information of AOR. No part of the information shown on this document may be used in any way or disclosed to others without the written consent of AOR. © 2019 AOR

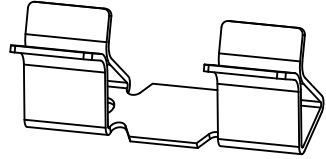

REV.	ECR/ECN No.	DESCRIPTION	DRAWN/DATE	CHECKED/DATE	APPROVED/DATE
C	ECN2021069	UPDATE FRAME	Abner 2021-07-08	Staven 2021-07-08	Sam 2021-07-08

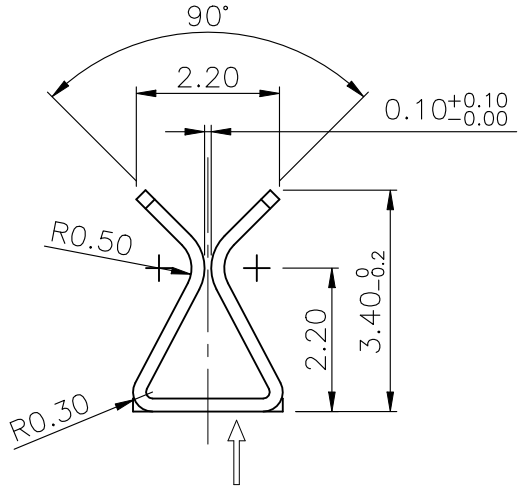
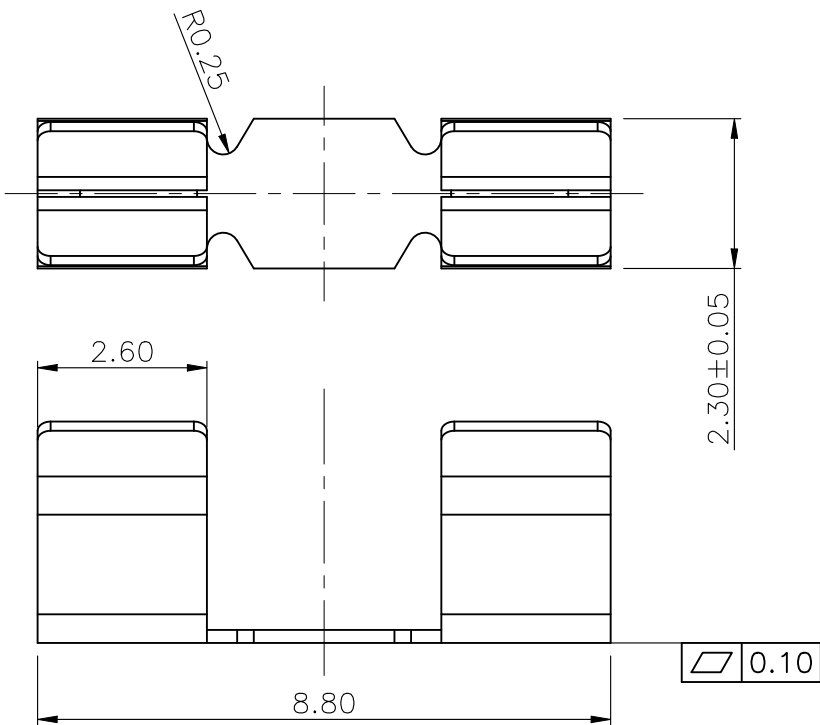

3D VIEW

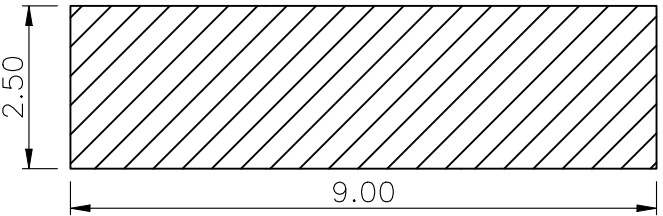
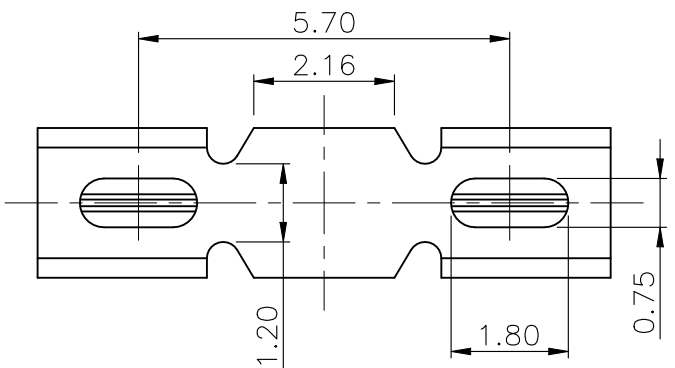

RECOMMEND PCB LAYOUT
TOLERANCE: ±0.05mm

PUNCH DIRECTION & BURRS DIRECTION

NOTES:

- MATERIAL: PHOSPHOR BRONZE T=0.15mm.
- FINISH:
GOLD FLASH ON SOLDER AREAS,
Ni 40-120u" UNDER PLATING OVER ALL.
- ALL MATERIAL MUST BE COMPLY WITH RoHS2.0

UNLESS OTHERWISE SPECIFIED TOLERANCES			ANGLE OF PROJECTION		 Amphenol Aorora Technology (Huizhou) Co.,Ltd
X.	±0.30	X. °	± 5'		
X.X	±0.25	X.X °	± 4'		
X.XX	±0.20	X.XX °	± 3'	DOC TYP Customer Drw	
X.XXX	±0.15	X.XXX °	± 2'		
LINEAR DIMS		ANGLES DIMS		DRAWN DATE	Staven 2016-12-02
DWG NO.: A-S0288				DESIGN DATE	Staven 2016-12-02
MATERIAL SEE NOTES				CHECKED DATE	Biao 2016-12-02
FINISHED SEE NOTES				APPROVED DATE	Biao 2016-12-02
SIZE	PART NUMBER:		REV.		
A4	Z002-4B7C1-11000		B		
SCALE	1:1	UNIT : mm	SHEET	1 OF 1	

1. PACKING INTO REEL:

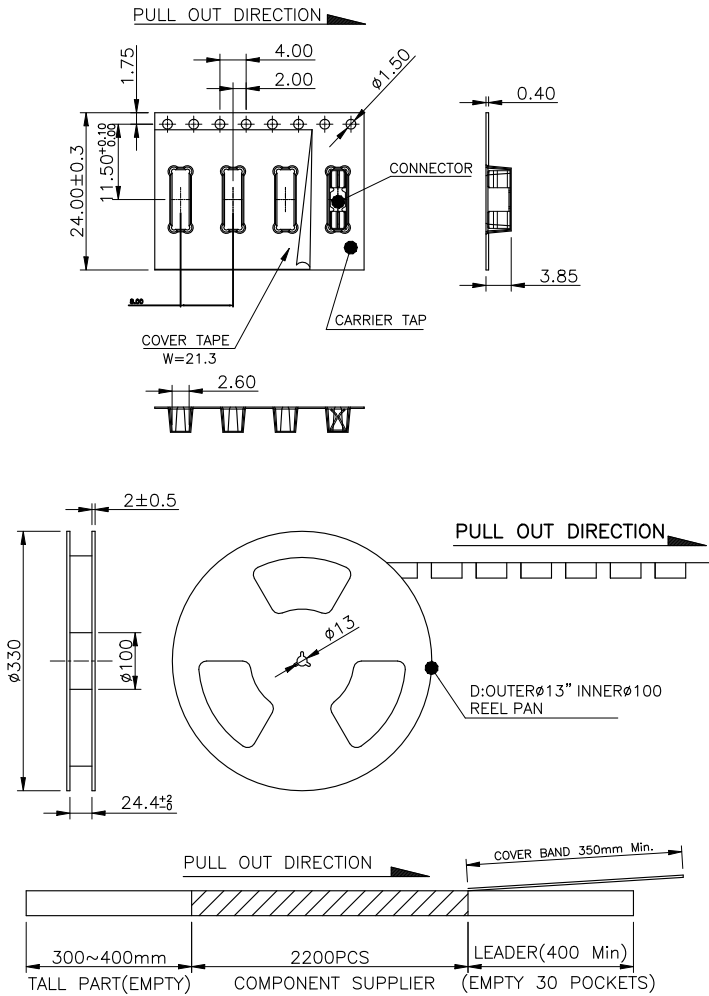

NOTES:

1. MATERIAL:
 - 1.1 CARRY TAPE:PS,T=0.4mm,COLOR:TRANSPARENT.
 - 1.2 REEL:HIPS,BLUE.
 - 1.3 SHIM:PE,CLEAR.
2. PRIMARY PACKING:2200PCS/REEL.
3. SECONDARY PACKING:10REELS/CARTON(22000PCS/CARTON).
4. PEELING RESISTANCE: 0.1N~0.9N(10~90gf);
PEELING ANGLE: 165°~180°;
PEELING SPEED: 300mm/minutes.
5. NET WEIGHT: 0.093g
6. CATON GROSS WEIGHT: 7.4Kg, NET WEIGHT: 2.05Kg

2

2. PACKING INTO CARTON:

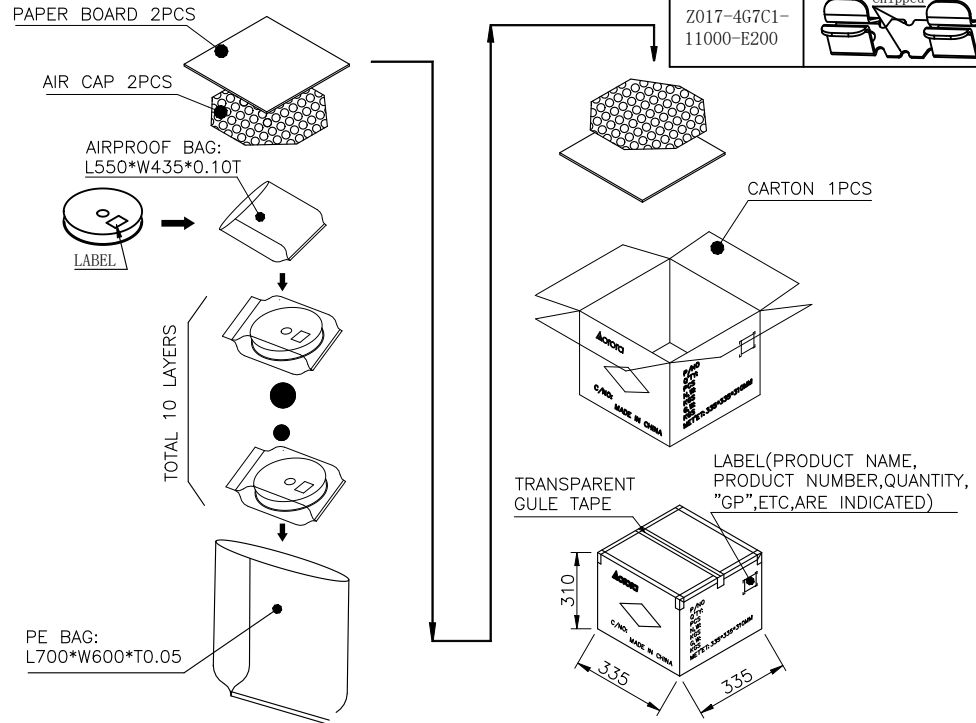

TABLE:

NO.	Sketch Map	Difference
Z002-4B7C1-11000		H3.4 Gap0.1mm
Z00U-4B7C1-11000		H3.4 Gap0.3mm
Z017-4G7C1-11000-E200		H3.4 Gap0.3mm Chipped

REV.	ECR/ECN No.	DESCRIPTION	DRAWN/DATE	CHECKED/DATE	APPROVED/DATE
C		New specifications	Staven 2019-03-04	Peng Li 2019-03-04	Judy 2019-03-04
D		UPDATE FRAME	Abner 2022-05-24	Staven 2022-05-24	Sam 2022-05-24

UNLESS OTHERWISE SPECIFIED TOLERANCES				ANGLE OF PROJECTION		Amphenol AORORA	
X.	±0.30	X. °	± 5'			Amphenol Aorora Technology (Huizhou) Co.,Ltd	
X.X	±0.25	X.X °	± 4'				
X.XX	±0.20	X.XX °	± 3'	DOC Typ Assembly Drw		TITLE: H3.4 CLIP	
X.XXX	±0.15	X.XXX °	± 2'	DRAWN	Abner	SIZE A4	PART NUMBER: SEE TABLE
LINEAR DIMS		ANGLES DIMS		DATE	2022-05-24		
DWG NO.: A-H0167		DESIGN		DATE	2022-05-24		
MATERIAL SEE NOTES		CHECKED		DATE	2022-05-24		
FINISHED SEE NOTES		APPROVED		DATE	2022-05-24	REV. D	SHEET 1 OF 1

1

2

3

4