

TOLERANCE UNLESS OTHERWISE SPECIFIED IN MM:

0.0	± 0.35	ANGLE	0.	±3°
0.00	± 0.25		0.0	±2°
0.00	± 0.15		0.00	±1°

THIS IS A C.A.D. GENERATED DRAWING
DO NOT MAKE MANUAL REVISIONS TO MASTER.

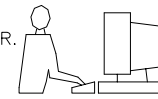

ISSUE NUMBER
ORIGINAL ①

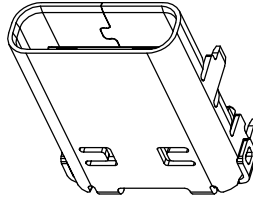
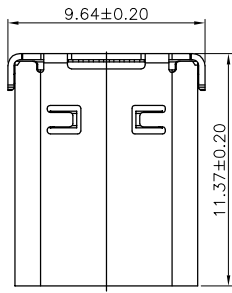

3D VIEW

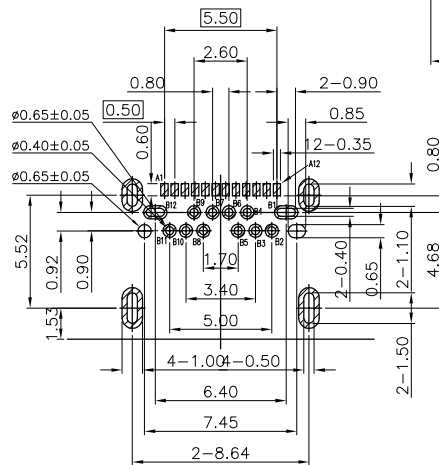
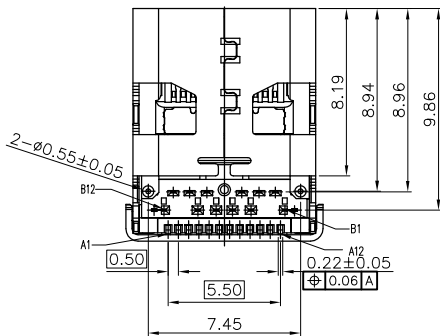
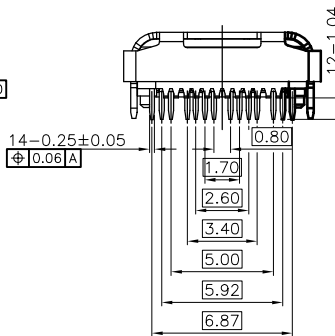
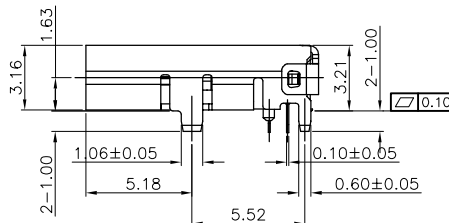
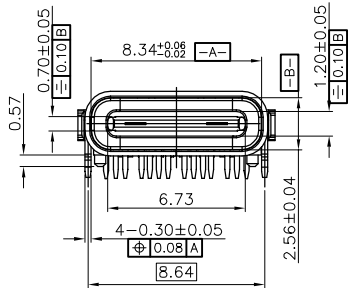

RECOMMENDED PCB LAYOUT (TOP VIEW)
(THICKNESS=1.0±0.10mm)
(TOLERANCE=±0.05mm)

NOTES:

- MATERIAL SPECIFICATION
 - SHELL: SUS304R-1/4H T=0.30mm
 - SIGNAL: SUS301R-H T=0.10mm
 - RFI PAD: SUS301R-H T=0.08mm
 - HOUSING: PA46+20%G.F. UL94-V0 BLACK
 - TERMINAL: NKE012R-H T=0.10mm
- PLATING SPECIFICATION
 - CONTACT: GOLD PLATING ON MATING AREA, MATTE Sn 120~200u" ON SOLDERING AREA, 80~150u" NICKEL UNDER PLATING OVERALL
 - SHELL: NICKEL PLATED.
- MECHANICAL PERFORMANCE
 - INSERTION FORCE: 5N~20N.
 - WITHDRAWAL FORCE: 8N~20N.
 - DURABILITY: 10000 CYCLES.
- ELECTRICAL PERFORMANCE
 - CURRENT RATING: 1A.
 - LLCR: CONTACT: 40 mΩ MAX(INITIAL).
 - INSULATION RESISTANCE: UNMATED: 100 MΩ MIN.
 - DIELECTRIC WITHSTAND VOLTAGE: 100V AC.
- IR REFLOW:

THE PEAK TEMPERATURE ON BOARD SHALL BE MAINTAINED FOR 10 SECONDS AT 260±5°C.
- OPERATING TEMPERATURE RANGE: -40°C~85°C (WITHOUT LOSS FUNCTION).

PART NUMBERS

GOLD FLASH	690-024-231-031
15u"GOLD	690-024-331-031
30u"GOLD	690-024-631-031

HYBRID MOUNT (THRU-HOLE AND SURFACE MOUNT)



THIS SERIES FULLY CONFORMS TO THE EUROPEAN UNION DIRECTIVES 2011/65/EU FOR RoHS COMPLIANCY.

USB 3.1 TYPE C FEMALE



EDAC INC
TORONTO, ONTARIO
CANADA

YOUR CONNECTION TO QUALITY & SERVICE

THESE DRAWINGS AND SPECIFICATIONS ARE THE PROPERTY OF EDAC INC. AND SHALL NOT BE REPRODUCED, OR COPIED OR USED AS THE BASIS FOR THE MANUFACTURE OR SALE OF APPARATUS WITHOUT WRITTEN PERMISSION.

ACAD REFERENCE NO.: 690-024-231-031

DRAWN: N.SONDH DATE: JUN.29/2015

CHECKED: DATE:

PART NUMBER

SEE TABLE

SHEET 1 OF 2

DRAWING NUMBER
690-024-231-031

ISSUE
1

TOLERANCE UNLESS OTHERWISE SPECIFIED IN MM:

0.0 ±0.35
0.00 ±0.25
0.00 ±0.15

ANGLE
0. ±3°
0.0 ±2°
0.00 ±1°

THIS IS A C.A.D. GENERATED DRAWING
DO NOT MAKE MANUAL REVISIONS TO MASTER.

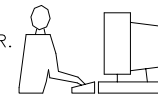

ISSUE NUMBER

ORIGINAL

1

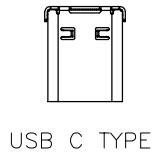
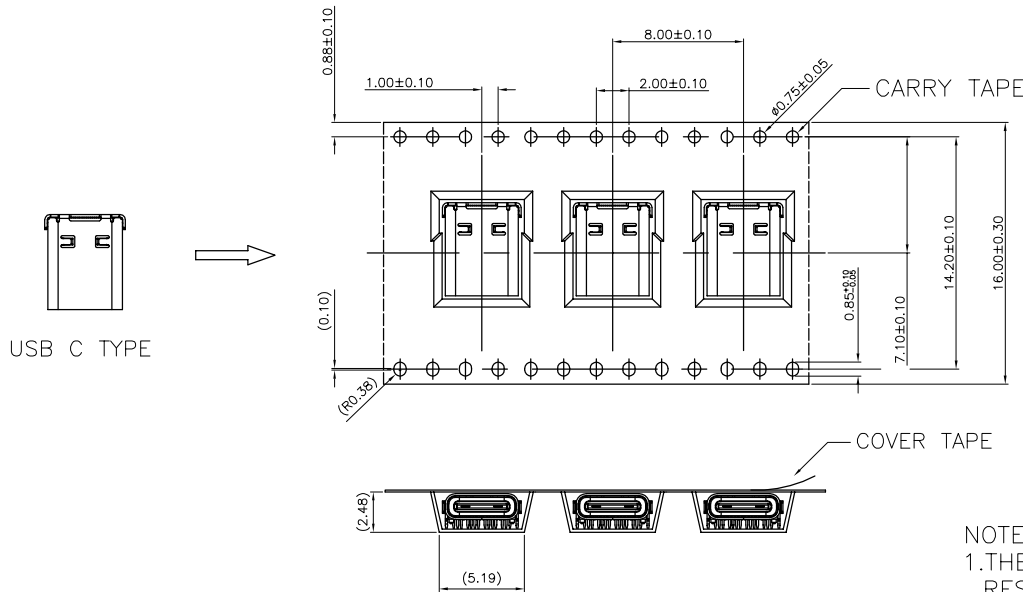
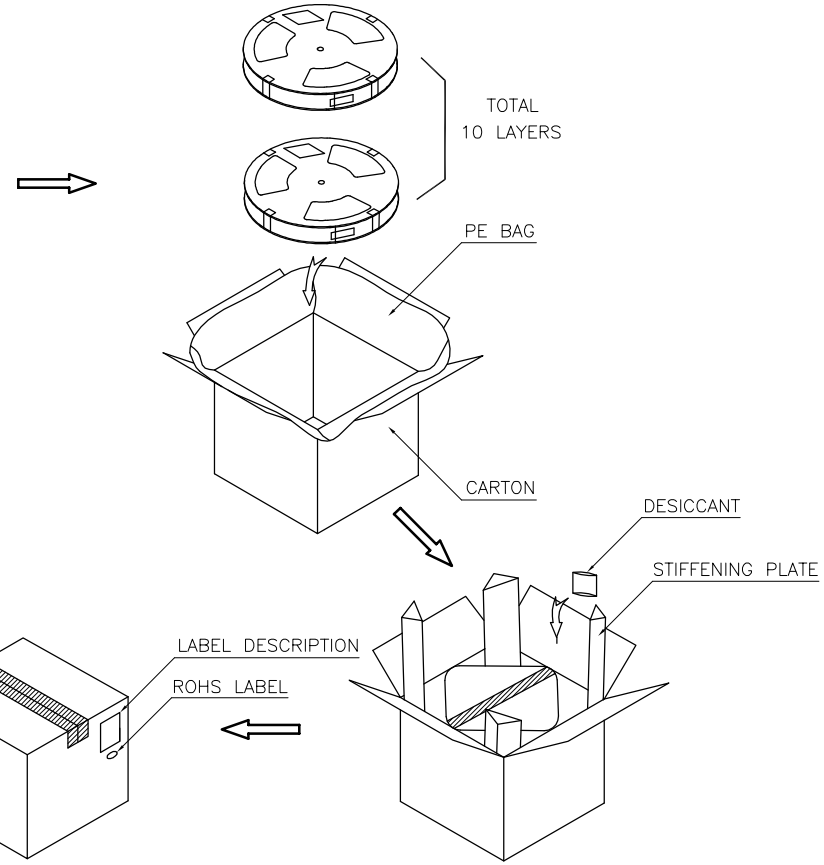
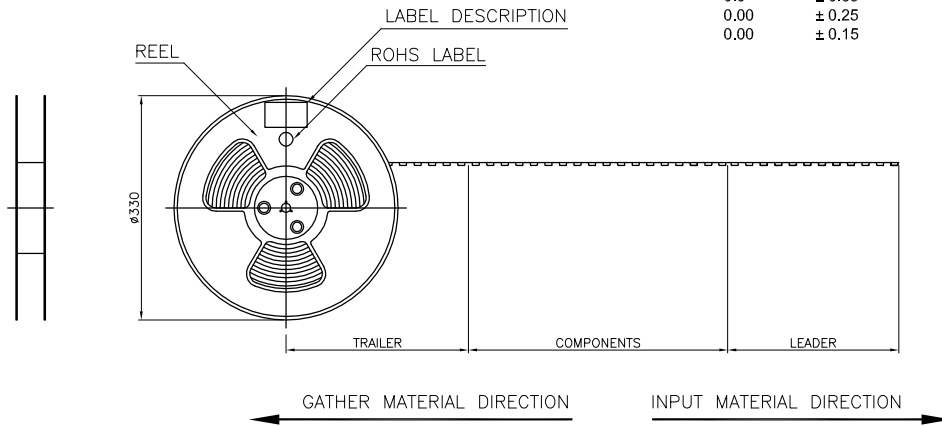

NOTES:

1. THE START AND END OF EACH REEL, BASED ON THE ACTUAL QUANTITY, RESERVED 5--15PCS SPACE;
2. COVER TAPE AND CARRY TAPE PEEL: 10g~130g; PEEL DEG.: 165°~175°; PEEL SPEED: 250~300mm/min;
3. QTY': 800PCS/REEL, 10REEL/CARTON, TOTAL 8000PCS/CARTON;



THIS SERIES FULLY CONFORMS TO THE EUROPEAN UNION DIRECTIVES 2011/65/EU FOR RoHS COMPLIANCE.

USB 3.1 TYPE C FEMALE



EDAC INC
TORONTO, ONTARIO
CANADA

YOUR CONNECTION TO QUALITY & SERVICE

THESE DRAWINGS AND SPECIFICATIONS ARE THE PROPERTY OF EDAC INC. AND SHALL NOT BE REPRODUCED OR COPIED OR USED AS THE BASIS FOR THE MANUFACTURE OR SALE OF APPARATUS WITHOUT WRITTEN PERMISSION.

ACAD REFERENCE NO.: 690-024-231-031

DRAWN: N.SONDH

DATE: JUN.29/2015

CHECKED:

DATE:

PART NUMBER

SEE TABLE

SHEET 2 OF 2

DRAWING NUMBER

690-024-231-031

ISSUE

1