

THIS DRAWING IS UNPUBLISHED. RELEASED FOR PUBLICATION
 © COPYRIGHT - By - ALL RIGHTS RESERVED.

LOC		DIST		REVISIONS			
P	LTR	DESCRIPTION	DATE	DWN	APVD		
M		REV PER ECO 15-000491	4-24-15	CT	CD		

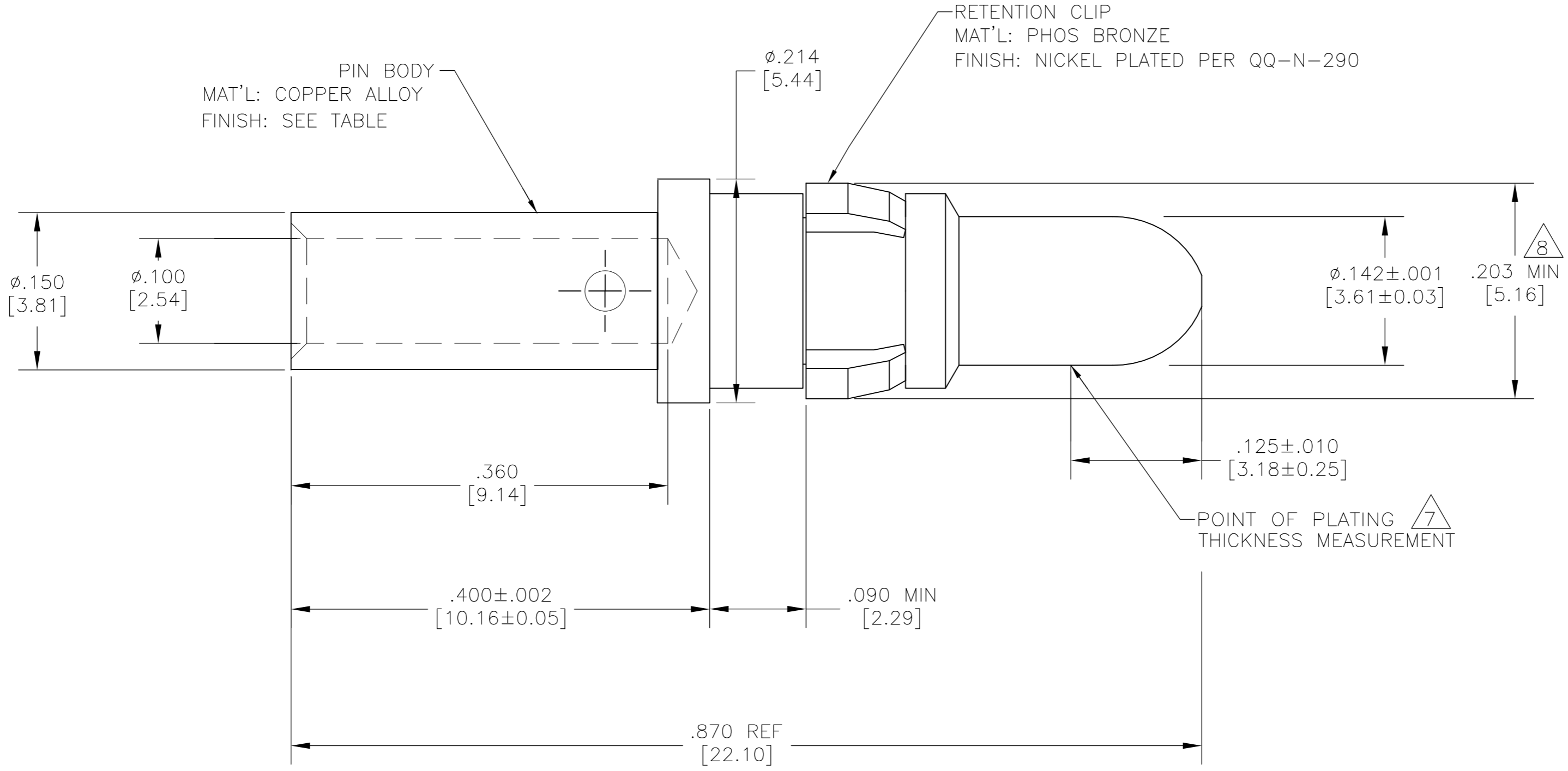

- THIS PART CONFORMS TO REQUIREMENTS FOR DANIELS CRIMP TOOL NO. M300-BT, WITH DANIELS POSITIONER PART NO. SP689, STRIP LENGTH .375, SETTING #1.
- MATES WITH 212008-1 IN AMPLIMITE CONNECTOR ASSEMBLIES ONLY.
- FINISH: PLATED GOLD .000050 [0.00127] MIN THK PER ASTM-B-488 OVER NICKEL .000050 [0.00127] MIN THK PER QQ-N-290.
- FINISH: PLATED GOLD .000030 [0.00076] MIN THK PER ASTM-B-488 OVER NICKEL .000050 [0.00127] MIN THK PER QQ-N-290.
- WIRE BARREL WILL ACCEPT #12-#14 AWG WIRE.
- RETENTION CLIP DIAMETER MUST BE MEASURED USING RING GAGE.
- RESTRICTED PART NUMBER.
- FINISH:
 MATING AREA: GOLD PER ASTM-B-488 (TYPE II) OVER NICKEL PER AMS-QQ-N-290
 NON-MATING AREA: GOLD STRIKE PER ASTM-B-488 OVER NICKEL PER AMS-QQ-N-290
- DIMENSION MUST BE MEASURED USING A RING GAGE.

3	1-212007-1
4	212007-2
8	212007-1
FINISH	PART NUMBER

THIS DRAWING IS A CONTROLLED DOCUMENT.		DWN	C.C.THOMAS	11/10/00		TE Connectivity		
DIMENSIONS: INCHES [mm]		CHK	D.MILLER	11/10/00		NAME		
TOLERANCES UNLESS OTHERWISE SPECIFIED:		APVD	D.MILLER	11/10/00		ASSEMBLY, PIN CONTACT		
0 PLC ± - 1 PLC ± - 2 PLC ± - 3 PLC ± .005 [0.13] 4 PLC ± - ANGLES ± -		PRODUCT SPEC	108-10045			POWER VIII, #12 & #14 AWG		
MATERIAL SEE CALLOUTS		FINISH	SEE TABLE		114-10014	SIZE	A2	
				WEIGHT	-	CAGE CODE	00779	
				CUSTOMER DRAWING		DRAWING NO	C=212007	
				SCALE	10:1	SHEET	1 of 1	
						RESTRICTED TO	-	
						REV	M	