

NOTES:
1. REFER TO HEADER DRAWING 92140 AND EJECT MECHANISM 95079 FOR ADDITIONAL DIMENSIONS, MATERIAL, AND PLATING INFORMATION.

mat'l. code		surface ISO1302 ✓		tolerance ISO1101 ISO406		projection MM		product family MCS	
l trechn nodr		date		tolerances unless otherwise specified		scale 1:1		title 5V EJECT HEADER ASSY	
L	V20418 LP	3/1/02	angle 0°	0.X±0.3				dwg no	sheet 1 of 9
M	N05-0054 WB	03/01/05	0°±2'	0.XX±0.13				95620	A4
N	BLX-N-011441 ZK	04/02/12		0.XXX±0.051				type	Product Customer Drawing
			dr	D.SHEAFFER	11/17/94				
			enr	D.BRANN	12/7/94				
			chr	D.BRANN	12/7/94				
			appd	D.BRANN	12/7/94				
sheet index	revision	N	N	N	N	N	N	N	N
	sheet	1	2	3	4	5	6	7	8

DESCRIPTION: ABOVE P.C.B., DECK AND PUSH-ROD LOCATION ARE AS VIEWED BY USER.

PRODUCT NO. 95620-XXXX	PUSH ROD LOCATION	SOLDER TAIL ⑤	STAND-OFF HEIGHT DIM "L"	EJ. HEADER ASSY 92140-XXX ④	EJ. MECHANISM ASSY 95079-XXXX ⑥	SOLDERABLE HOLD DOWN ⑦ (4)	MOUNTING STYLE TO PCB AND PUSH-ROD LOCATION	USED WITH/COMMENTS
000CA	RIGHT	R/A	0.0	000	00CA			
000CAH ⑦	RIGHT	R/A	0.0	000	00CA	93925-001		
001CA	RIGHT	SMT-STG	0.0	001	00CA			
002CA	RIGHT	SMT-IL	0.0	002	00CA			
020CA	RIGHT	R/A	2.0	040	02CA			
040CA	RIGHT	R/A	4.0	010	04CA			
050CA	RIGHT	R/A	5.0	020	05CA			
050CAH ⑦	RIGHT	R/A	5.0	020	05CA	93925-004		
100CA	LEFT	R/A	0.0	000	10CA			
100CAH ⑦	LEFT	R/A	0.0	000	10CA	93925-001		
101CA	LEFT	SMT-STG	0.0	001	10CA			
102CA	LEFT	SMT-IL	0.0	002	10CA			
120CA	LEFT	R/A	2.0	040	12CA			
140CA	LEFT	R/A	4.0	010	14CA			
150CA	LEFT	R/A	5.0	020	15CA			
005CA	RIGHT	R/A	0.0	005	00CA			
025CA	RIGHT	R/A	0.0	045	00CA			95620-020CA or -120CA
105CA	LEFT	R/A	0.0	005	10CA			95620-000CA or -100CA
125CA	LEFT	R/A	0.0	045	10CA			95620-020CA or -120CA

NOTES:

- MATERIAL:
 - HEADER ASSY:
PLASTIC HOUSING: HIGH TEMPERATURE THERMOPLASTIC UL94V-0 BLACK - ABOVE PCB
HIGH TEMPERATURE THERMOPLASTIC UL94V-0 (WHITE) - BELOW PCB
PIN: PHOSPHOR BRONZE
 - EJECT MECHANISM ASSY:
PLASTIC GUIDE: HIGH TEMPERATURE THERMOPLASTIC UL94V-0 BLACK
PLASTIC PUSH-ROD BUTTON: HIGH TEMPERATURE THERMOPLASTIC UL94V-0 BLACK
COVER PLATE, EJECT PLATE, LINK ARM,
PUSH ROD: STAINLESS STEEL
EMI CONTACT: PHOSPHOR BRONZE
- FINISH (PIN)
UNDER PLATING: 0.5um Ni
CONTACT AREA: 0.076 µm MIN. GOLD
SOLDER TAIL: 2.5um Sn-Pb
- DIM "X"

4.25±.1	3.5±.1	5.0±.1
OTHERS	36,67	1,17,34,35,51,68
- RECOMMENDED HOLD DOWN - 2mm SCREWS (95121-XXX) AND HEXNUTS (92869-001). RECOMMENDED SCREW TORQUE: 1.0 TO 1.5 MAX in-lbs. (1.2-1.7 cm-kgs).
- SOLDER TAIL KEY/PCB LAYOUT:
R/A = RIGHT ANGLE PIN-THROUGH-HOLE-PAGE 6
SMT-STG = STAGGERED SURFACE MOUNT-PAGE 7
SMT-IL = SURFACE MOUNT IN-LINE (SINGLE ROW)-PAGE 8

6. BOARD KEEP OUT ZONE- PAGE 9

⑦ SOLDERABLE HOLD DOWN

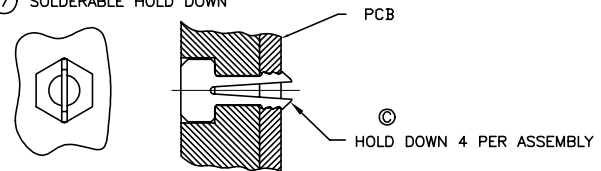

8. PRODUCT SPEC:110-263

mat'l. code	surface ISO1302 ✓	tolerance ISO1101 ISO406	projection ④	product family MCS
ltr ecn nodr	tolerances unless otherwise specified		MM	title 5V EJECT HEADER ASSY
date	angle 0°±2'	0.X±0.3 0.XX±0.13 0.XXX±0.051	scale 1:1	dwg no 95620
	dr D.SHEAFFER	11/17/94		sheet 2 of 9
	enr D.BRANN	12/7/94		size A4
	chr D.BRANN	12/7/94		type Product Customer Drawing
sheet index	revision sheet			

DESCRIPTION: ABOVE P.C.B., DECK AND PUSH-ROD LOCATION ARE AS VIEWED BY USER.

PRODUCT NO. 95620-XXXX	PUSH ROD LOCATION	SOLDER TAIL ⑤	STAND-OFF HEIGHT DIM "L"	EJ. HEADER ASSY 92140-XXX ①	EJ. MECHANISM ASSY 95079-XXXX ②	SOLDERABLE HOLD DOWN (4) ③	MOUNTING STYLE TO PCB AND PUSH-ROD LOCATION	USED WITH/COMMENTS
000CALF	RIGHT	R/A	0.0	000LF	00CA			
000CAHLF ⑩	RIGHT	R/A	0.0	000LF	00CA	93925-001		
001CALF	RIGHT	SMT-STG	0.0	001LF	00CA			
002CALF	RIGHT	SMT-IL	0.0	002LF	00CA			
020CALF	RIGHT	R/A	2.0	040LF	02CA			
040CALF	RIGHT	R/A	4.0	010LF	04CA			
050CALF	RIGHT	R/A	5.0	020LF	05CA			
050CAHLF ⑩	RIGHT	R/A	5.0	020LF	05CA	93925-004		
100CALF	LEFT	R/A	0.0	000LF	10CA			
100CAHLF ⑩	LEFT	R/A	0.0	000LF	10CA	93925-001		
101CALF	LEFT	SMT-STG	0.0	001LF	10CA			
102CALF	LEFT	SMT-IL	0.0	002LF	10CA			
120CALF	LEFT	R/A	2.0	040LF	12CA			
140CALF	LEFT	R/A	4.0	010LF	14CA			
150CALF	LEFT	R/A	5.0	020LF	15CA			
005CALF	RIGHT	R/A	0.0	005LF	00CA			95620-000CALF or -100CALF
025CALF	RIGHT	R/A	0.0	045LF	00CA			95620-020CALF or -120CALF
105CALF	LEFT	R/A	0.0	005LF	10CA			95620-000CALF or -100CALF
125CALF	LEFT	R/A	0.0	045LF	10CA			95620-020CALF or -120CALF

NOTES:

- MATERIAL:
 - 1.1 HEADER ASSY:
 - PLASTIC HOUSING: HIGH TEMPERATURE THERMOPLASTIC UL94V-0 BLACK - ABOVE PCB
 - HIGH TEMPERATURE THERMOPLASTIC UL94V-0 (WHITE) - BELOW PCB
 - PIN: PHOSPHOR BRONZE
 - 1.2 EJECT MECHANISM ASSY:
 - PLASTIC GUIDE: HIGH TEMPERATURE THERMOPLASTIC UL94V-0 BLACK
 - PLASTIC PUSH-ROD BUTTON: HIGH TEMPERATURE THERMOPLASTIC UL94V-0 BLACK
 - COVER PLATE, EJECT PLATE, LINK ARM, PUSH ROD: STAINLESS STEEL
 - EMI CONTACT: PHOSPHOR BRONZE
- FINISH (PIN)
 - UNDER PLATING: 0.5um Ni
 - CONTACT AREA: 0.076 μm MIN. GOLD
- SOLDER TAIL: 2.5um Sn-Pb

DIM "X"	4.25±.1	3.5±.1	5.0±.1
OTHERS	36,67	1,17,34,35,51,68	
- RECOMMENDED HOLD DOWN - 2mm SCREWS (95121-XXX) AND HEXNUTS (92869-001), RECOMMENDED SCREW TORQUE: 1.0 TO 1.5 MAX in-lbs. (1.2-1.7 cm-kgs).
- SOLDER TAIL KEY/PCB LAYOUT:
 - R/A = RIGHT ANGLE PIN-THROUGH-HOLE-PAGE 6
 - SMT-STG = STAGGERED SURFACE MOUNT-PAGE 7
 - SMT-IL = SURFACE MOUNT IN-LINE (SINGLE ROW)-PAGE 8
- IF LEAD FREE P/N. THE HOUSING WILL WITHSTAND EXPOSURE TO 260°C PEAK TEMPERATURE SOLDER TAIL : SMT-IL, SMT-STG CAN RESIST 40 SECONDS IN A CONVECTION, INFRA-RED OR VAPOR PHASE REFLOW OVEN. SOLDER TAIL : R/A CAN RESIST 10 SECONDS IN A WAVE SOLDER APPLICATION WITH A 1.00MM MINIMUM THICK CIRCUIT BOARD.
- IF LEAD FREE P/N. THE PRODUCT MEETS EUROPEAN UNION DIRECTIVES AND OTHER COUNTRY REGULATIONS AS DISCRIBLED IN GS-22-008
- LEAD FREE P/N PACKAGING MEETS GS-14-920 SPECIFICATION

9. BOARD KEEP OUT ZONE- PAGE 9

⑩ SOLDERABLE HOLD DOWN

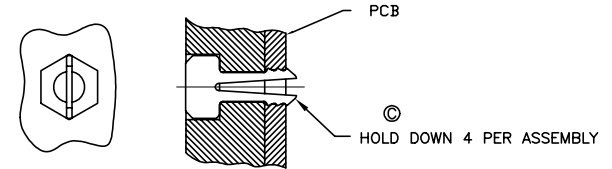

11. PRODUCT SPEC:110-263

mat'l. code		surface <input checked="" type="checkbox"/> ISO1302		tolerance <input checked="" type="checkbox"/> ISO1101 <input checked="" type="checkbox"/> ISO406		projection		product family	
l t r e c n n o d r		date		tolerances unless otherwise specified		MM		MCS	
N		angle		0.X±0.3		scale 1:1		5V EJECT HEADER ASSY	
		0°±2'		0.XX±0.13				dwg no	
		dr		D.SHEAFFER		11/17/94		sheet 3 of 9	
		enr		D.BRANN		12/7/94		size	
		chr		D.BRANN		12/7/94		A4	
		appd		D.BRANN		12/7/94		type	
sheet		revision						Product Customer Drawing	
index		sheet							

DESCRIPTION: BELOW P.C.B., DECK AND PUSH-ROD LOCATION ARE AS VIEWED BY USER.

PRODUCT NO. 95620-XXXXX	PUSH ROD LOCATION	SOLDER TAIL ⑤	STAND-OFF HEIGHT DIM "L"	EJ. HEADER ASSY 92140-XXX ④	EJ. MECHANISM ASSY 95079-XXXX ③	SOLDERABLE HOLD DOWN (4) ②	MOUNTING STYLE TO PCB AND PUSH-ROD LOCATION	USED WITH/COMMENTS	
500CA	RIGHT	R/A	0.0	500	10CA				
500CAH	RIGHT	R/A	0.0	500	10CA	93925-001			
501CA	RIGHT	SMT-STG	0.0	501	10CA				
502CA	RIGHT	SMT-IL	0.0	502	10CA				
503CA	RIGHT	SMT-IL	0.0	503	10CA				
520CA	RIGHT	R/A	2.0	540	12CA				
540CA	RIGHT	R/A	4.0	510	14CA				
550CA	RIGHT	R/A	5.0	520	15CA				
600CA	LEFT	R/A	0.0	500	00CA				
601CA	LEFT	SMT-STG	0.0	501	00CA				
602CA	LEFT	SMT-IL	0.0	502	00CA				
620CA	LEFT	R/A	2.0	540	02CA				
640CA	LEFT	R/A	4.0	510	04CA				
650CA	LEFT	R/A	5.0	520	05CA				
505CA	RIGHT	R/A	0.0	505	10CA				95620-500CA or -600CA
525CA	RIGHT	R/A	0.0	545	10CA				95620-520CA or -620CA
605CA	LEFT	R/A	0.0	505	00CA			95620-500CA or -600CA	
625CA	LEFT	R/A	0.0	545	00CA			95620-520CA or -620CA	

NOTES:

1. MATERIAL:
 1.1 HEADER ASSY:
 PLASTIC HOUSING: HIGH TEMPERATURE THERMOPLASTIC UL94V-0 BLACK - ABOVE PCB
 HIGH TEMPERATURE THERMOPLASTIC UL94V-0 (WHITE) - BELOW PCB
 PIN: PHOSPHOR BRONZE

1.2 EJECT MECHANISM ASSY:
 PLASTIC GUIDE: HIGH TEMPERATURE THERMOPLASTIC UL94V-0 BLACK
 PLASTIC PUSH-ROD BUTTON: HIGH TEMPERATURE THERMOPLASTIC UL94V-0 BLACK
 COVER PLATE, EJECT PLATE, LINK ARM,
 PUSH ROD: STAINLESS STEEL
 EMI CONTACT: PHOSPHOR BRONZE

2. FINISH (PIN)
 UNDER PLATING: 0.5um Ni
 CONTACT AREA: 0.076 µm MIN. GOLD

SOLDER TAIL: 2.5um Sn-Pb

③ DIM "X"

4.25±.1	3.5±.1	5.0±.1
OTHERS	36,67	1,17,34,35,51,88

4. RECOMMENDED HOLD DOWN - 2mm SCREWS (95121-XXX) AND HEXNUTS (92869-001), RECOMMENDED SCREW TORQUE: 1.0 TO 1.5 MAX in-lbs. (1.2-1.7 cm-kgs).

⑤ SOLDER TAIL KEY/PCB LAYOUT:
 R/A = RIGHT ANGLE PIN-THROUGH-HOLE-PAGE 6
 SMT-STG = STAGGERED SURFACE MOUNT-PAGE 7
 SMT-IL = SURFACE MOUNT IN-LINE (SINGLE ROW)-PAGE 8

6. BOARD KEEP OUT ZONE-PAGE 9
 7. PRODUCT SPEC:110-263

mat'l. code	surface ISO1302 ✓	tolerance ISO1101 ISO406	projection ④	product family MCS
ltr ecn nodr	date	tolerances unless otherwise specified	MM	title 5V EJECT HEADER ASSY
N		angle 0°±2'	scale 1:1	dwg no 95620
		dr D.SHEAFFER 11/17/94		sheet 4 of 9
		enr D.BRANN 12/7/94		size A4
		chr D.BRANN 12/7/94		type Product Customer Drawing
		appd D.BRANN 12/7/94		
sheet index	revision sheet			

DESCRIPTION: BELOW P.C.B., DECK AND PUSH-ROD LOCATION ARE AS VIEWED BY USER.

PRODUCT NO. 95620-XXXXX	PUSH ROD LOCATION	SOLDER TAIL ⑤	STAND-OFF HEIGHT DIM "L"	EJ. HEADER ASSY 92140-XXX Ⓐ	EJ. MECHANISM ASSY 95079-XXXX Ⓑ	SOLDERABLE HOLD DOWN (4) Ⓒ	MOUNTING STYLE TO PCB AND PUSH-ROD LOCATION	USED WITH/COMMENTS
500CALF	RIGHT	R/A	0.0	500LF	10CA			
500CAHLF	RIGHT	R/A	0.0	500LF	10CA	93925-001		
501CALF	RIGHT	SMT-STG	0.0	501LF	10CA			
502CALF	RIGHT	SMT-IL	0.0	502LF	10CA			
503CALF	RIGHT	SMT-IL	0.0	503LF	10CA			NO BOARD LOCATORS
520CALF	RIGHT	R/A	2.0	540LF	12CA			
540CALF	RIGHT	R/A	4.0	510LF	14CA			
550CALF	RIGHT	R/A	5.0	520LF	15CA			
600CALF	LEFT	R/A	0.0	500LF	00CA			
601CALF	LEFT	SMT-STG	0.0	501LF	00CA			
602CALF	LEFT	SMT-IL	0.0	502LF	00CA			
620CALF	LEFT	R/A	2.0	540LF	02CA			
640CALF	LEFT	R/A	4.0	510LF	04CA			
650CALF	LEFT	R/A	5.0	520LF	05CA			
505CALF	RIGHT	R/A	0.0	505LF	10CA			95620-500CA or -600CA
525CALF	RIGHT	R/A	0.0	545LF	10CA			95620-520CA or -620CA
605CALF	LEFT	R/A	0.0	505LF	00CA			95620-500CA or -600CA
625CALF	LEFT	R/A	0.0	545LF	00CA			95620-520CA or -620CA

NOTES:

- MATERIAL:
 - 1.1 HEADER ASSY:
PLASTIC HOUSING: HIGH TEMPERATURE THERMOPLASTIC UL94V-0 BLACK - ABOVE PCB
HIGH TEMPERATURE THERMOPLASTIC UL94V-0 (WHITE) - BELOW PCB
PIN: PHOSPHOR BRONZE
 - 1.2 EJECT MECHANISM ASSY:
PLASTIC GUIDE: HIGH TEMPERATURE THERMOPLASTIC UL94V-0 BLACK
PLASTIC PUSH-ROD BUTTON: HIGH TEMPERATURE THERMOPLASTIC UL94V-0 BLACK
COVER PLATE, EJECT PLATE, LINK ARM,
PUSH ROD: STAINLESS STEEL
EMI CONTACT: PHOSPHOR BRONZE
- FINISH (PIN)
UNDER PLATING: 0.5um Ni
CONTACT AREA: 0.076 μm MIN. GOLD
SOLDER TAIL: 2.5um Sn-Pb
- DIM "X"

4.25±.1	3.5±.1	5.0±.1
OTHERS	36,67	1,17,34,35,51,68
- RECOMMENDED HOLD DOWN - 2mm SCREWS (95121-XXX) AND HEXNUTS (92869-001). RECOMMENDED SCREW TORQUE: 1.0 TO 1.5 MAX in-lbs. (1.2-1.7 cm-kgs).
- SOLDER TAIL KEY/PCB LAYOUT:
R/A = RIGHT ANGLE PIN-THROUGH-HOLE-PAGE 6
SMT-STG = STAGGERED SURFACE MOUNT-PAGE 7
SMT-IL = SURFACE MOUNT IN-LINE (SINGLE ROW)-PAGE 8
- BOARD KEEP OUT ZONE-PAGE 9
- IF LEAD FREE P/N. THE HOUSING WILL WITHSTAND EXPOSURE TO 260°C PEAK TEMPERATURE
SOLDER TAIL : SMT-IL, SMT-STG CAN RESIST 40 SECONDS IN A CONVECTION, INFRA-RED OR VAPOR PHASE REFLOW OVEN.
SOLDER TAIL : R/A CAN RESIST 10 SECONDS IN A WAVE SOLDER APPLICATION WITH A 1.00MM MINIMUM THICK CIRCUIT BOARD.
- IF LEAD FREE P/N.THE PRODUCT MEETS EUROPEAN UNION DIRECTIVES AND OTHER COUNTRY REGULATIONS AS DISCRIBED IN GS-22-008
- LEAD FREE P/N PACKAGING MEETS GS-14-920 SPECIFICATION
- PRODUCT SPEC:110-263

mat'l. code	surface ISO1302 ✓	tolerance ISO1101 ISO406	projection 	product family MCS
l trechn nodr date	tolerances unless otherwise specified		MM	5V EJECT HEADER ASSY
N	angle 0°±2'	0.X±0.3 0.XX±0.13 0.XXX±0.051	scale 1:1	
	dr	D.SHEAFFER 11/17/94		dwg no 95620 sheet 5 of 9 size A4
	engr	D.BRANN 12/7/94		
	chr	D.BRANN 12/7/94		
	appd	D.BRANN 12/7/94		
sheet index	revision sheet			type Product Customer Drawing

Single Mount Right Angle

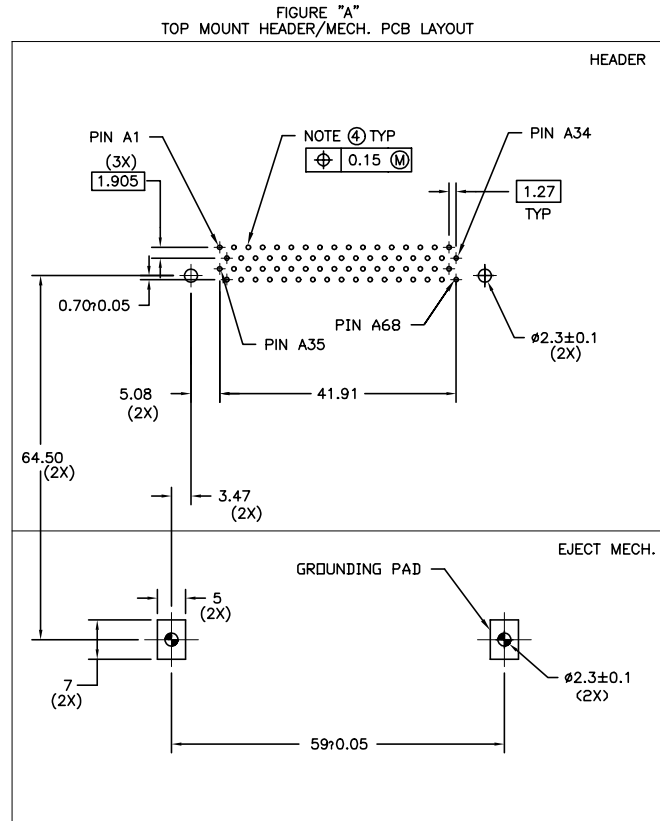

BOARD VIEW FROM CONNECTOR MOUNTED SIDE
TOP OF BOARD IN APPLICATION

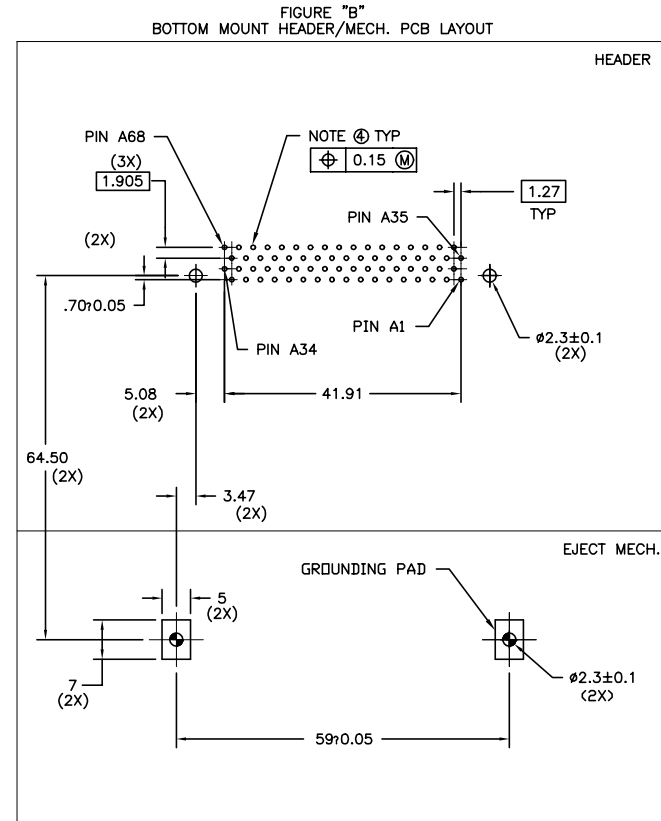

BOARD VIEW FROM CONNECTOR MOUNTED SIDE
BOTTOM OF BOARD IN APPLICATION

NOTES:

- 1 ALL TOLERANCES ±0.15 UNLESS NOTED.
- 2 KEEP-OUT ZONE FOR HEADERS W\STAND-OFF OPTIONS SEE SHEET 9 FIGURE A.
- 3 KEEP-OUT ZONE FOR HEADERS W\O STAND-OFF OPTIONS SEE SHEET 9 FIGURE B.
- ④ RECOMMENDED DIAMETER IS Ø1.0.
FOR PROCESSES USING PASTE REFLOW, HOLE MAY BE AS SMALL AS Ø0.79

mat'l. code	surface ISO1302	tolerance ISO1101 ISO406	projection MM	product family MCS
l trechn nodr date	tolerances unless otherwise specified		MM	title 5V EJECT HEADER ASSY
N	angle	0.X±0.3	scale 1:1	dwg no 95620
	0°±2'	0.XX±0.13		sheet 6 of 9
		0.XXX±0.051		size A4
	dr D.SHEAFFER	11/17/94	FCI	type Product Customer Drawing
	enr D.BRANN	12/7/94		
	chr D.BRANN	12/7/94		
	appd D.BRANN	12/7/94		
sheet index	revision sheet			

Surface Mount 2-Row

FIGURE "A"
TOP MOUNT HEADER/MECH. PCB LAYOUT

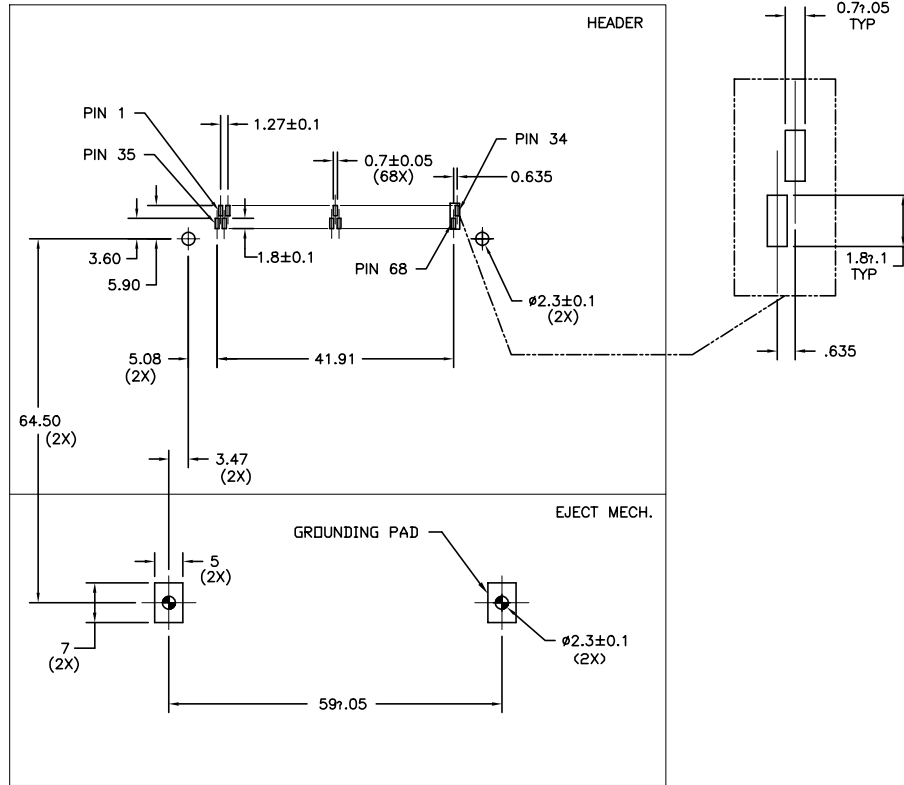

BOARD VIEW FROM CONNECTOR MOUNTED SIDE
TOP OF BOARD IN APPLICATION

FIGURE "B"
BOTTOM MOUNT HEADER/MECH. PCB LAYOUT

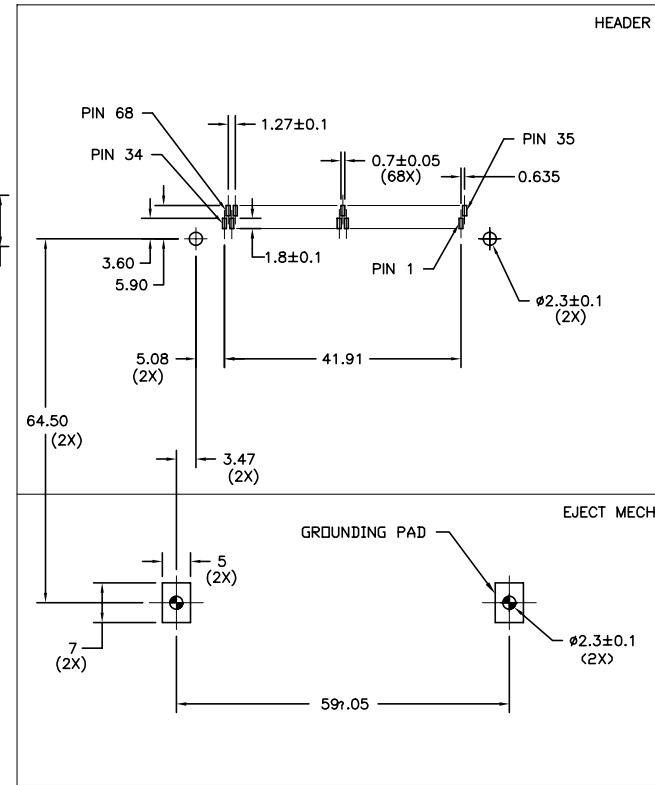

BOARD VIEW FROM CONNECTOR MOUNTED SIDE
BOTTOM OF BOARD IN APPLICATION

NOTES:

- ALL TOLERANCES ±0.15 UNLESS NOTED.
- KEEP-OUT ZONE FOR ASSEMBLIES SHOWN ON SHEET 9 FIGURE B.

mat'l. code	surface ISO1302 ✓	tolerance ISO1101 ISO406	projection MM	product family MCS
trnchn nodr	date	tolerances unless otherwise specified	scale 1:1	title 5V EJECT HEADER ASSY
N		angle 0°±2'		dwg no 95620
		dr D.SHEAFFER 11/17/94		sheet 7 of 9
		enr D.BRANN 12/7/94		size A4
		chr D.BRANN 12/7/94		type Product Customer Drawing
		appd D.BRANN 12/7/94		
sheet index	revision sheet			

Board Keep Out Zone
(NOT INCLUDING HEADER)

FIGURE "A"
KEEP OUT ZONE FOR STANDOFF VERSION

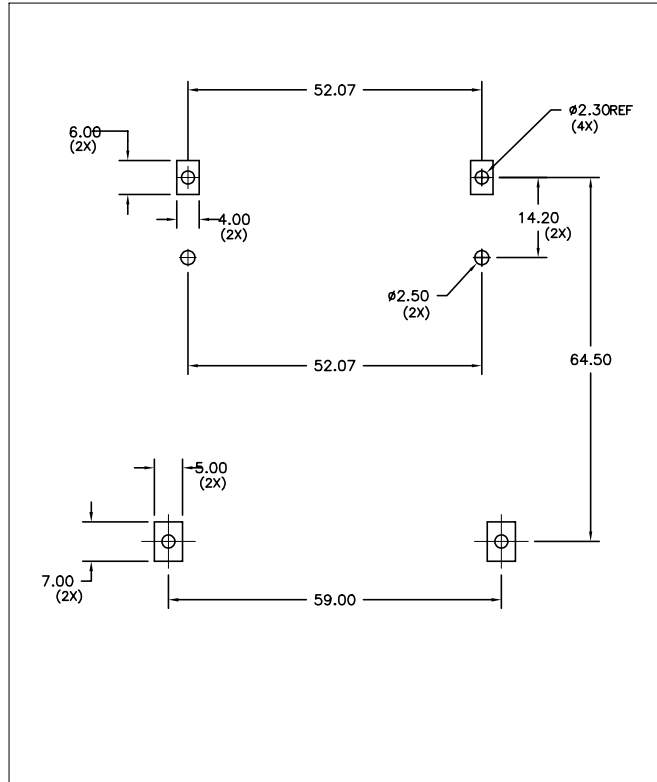
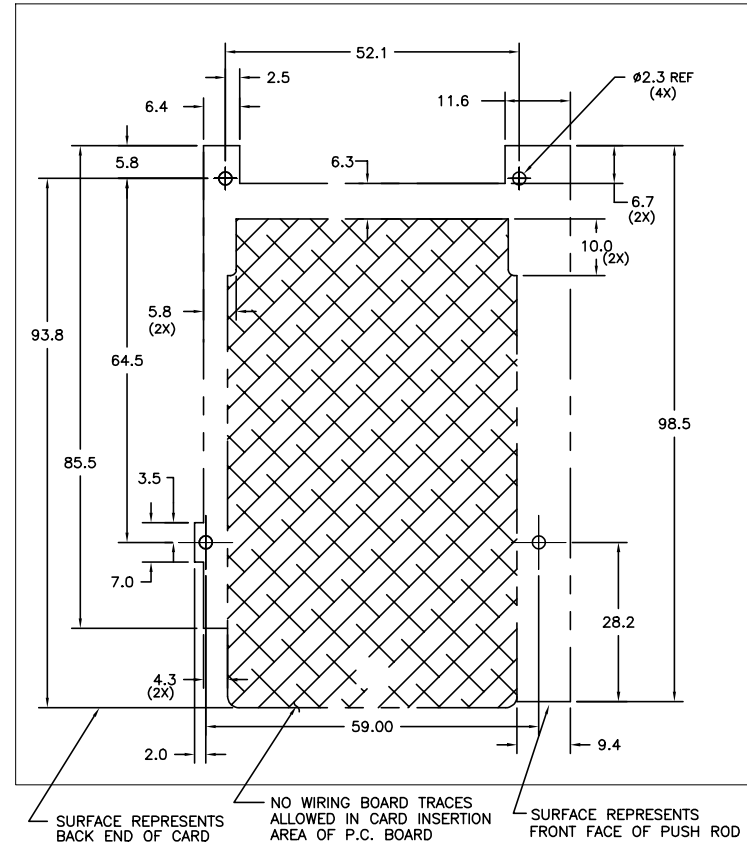

FIGURE "B" NOTE 1
KEEP OUT ZONE FOR NO STANDOFF VERSION
RIGHT HAND PUSHROD VERSION SHOWN
MIRROR IMAGE FOR LEFT HAND PUSHROD



NOTES:

- ① ALL DIMENSIONS SHOWN ARE NOMINAL AND DEFINE THE OUTSIDE SURFACES OF THE ASSEMBLY. A MINIMUM OF 0.25mm (0.010") CLEARANCE BETWEEN THE ASSEMBLY AND ANY COMPONENTS IS SUGGESTED.

mat'l. code	surface ISO1302 ✓	tolerance ISO1101 ISO406	projection ⊕	product family MCS
ltr ecn nodr	tolerances unless otherwise specified		⊕	title 5V EJECT HEADER ASSY
N	angle 0°±2'	0.X±0.3 0.XX±0.13 0.XXX±0.051	MM	scale 1:1
dr	D.SHEAFFER	11/17/94	FCI	dwg no
enr	D.BRANN	12/7/94		sheet 9 of 9
chr	D.BRANN	12/7/94		size A4
appd	D.BRANN	12/7/94		type Product Customer Drawing
sheet index	revision sheet			