

REVISIONS					
REV	ECO	DESCRIPTION	DATE	BY	APPR
A1	-	TECHNICAL DATA SHEET RELEASE	12-MAY-14	KMM	RFC
B1	-	REVISED THE WIRING DIAGRAM	16-MAY-18	MRF	JB

WIRING DIAGRAM

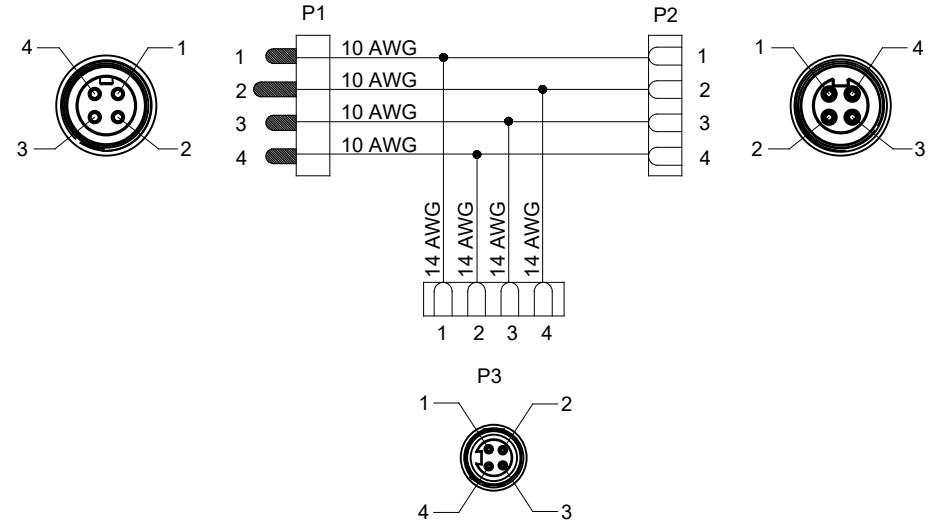

Amphenol P/N	ROCKWELL P/N	MOLEX	TURCK
P28968	280-RT35	TC40140-20	GSDM/GKDM/RKM44

TECHNICAL DATA:

- MATERIALS:**
 COUPLING NUT: MACHINED ALUMINUM, ANODIZED
 INSULATION INSERT: THERMOPLASTIC, UL 94/V-0
 CONTACT: GOLD FLASH PLATING OVER COPPER ALLOY
 OVERMOLD MATERIAL: THERMOPLASTIC COLOR: BLACK
 CONDUCTOR INSULATION: PVC
- ELECTRICAL DATA:**
 CURRENT (MAX): 15A
 VOLTAGE (MAX): 600V AC/DC
 INSULATION RESISTANCE (MIN): 5000M OHMS
 DIELECTRIC TEST VOLTAGE: 2200V
 SHORT CIRCUIT AMPERAGE RATING: 65kA - BREAKERS AND FUSES
- MECHANICAL DATA:**
 TEMPERATURE RANGE: -40°C TO 90°C
 PROTECTION: IP67 (MATED CONDITION)
 MATING CYCLES: >500
 VIBRATION RESISTANCE PER MIL-STD-202 METHOD 204
 THERMAL SHOCK PER MIL-STD-202 METHOD 207
 48 HOUR SALT SPRAY PER MIL-STD-202 METHOD 101
- RoHS COMPLIANT**
- UL 2237 LISTED ASSEMBLY**
 UL FILE NUMBERS: E339703

PART NUMBER		DESCRIPTION		ITEM
P28968		M35 PB LITE, 4 PIN, REDUCING TEE, BLACK		
MATERIALS LIST				
UNLESS OTHERWISE SPECIFIED		SIGNATURES		DATE
1) All dimensions are in metric (mm).		DRAWN: KMM		12-MAY-14
2) Tolerances are as follows:		CHECKED: MRF		12-MAY-14
1 PL DEC ±0.30 Fractions ±1/64		ENGINEER: KMM		
2 PL DEC ±0.15 Angles ±1°		APPROVAL: RFC		12-MAY-14
3 PL DEC ±0.08		CUSTOMER:		
3) Note reference =		THIS DRAWING IS SUPPLIED FOR INFORMATION ONLY. DESIGN FEATURES, SPECIFICATIONS AND PERFORMANCE DATA SHOWN HEREON ARE THE PROPERTY OF THE AMPHENOL CORPORATION. NO RIGHTS OF REPRODUCTION ARE IMPLIED. ALL DIMENSIONS ARE SUBJECT TO NORMAL MANUFACTURING VARIATIONS.		
MATERIAL SPECIFICATIONS:		CUSTOMER:		
PROCESS SPECIFICATIONS:		CUSTOMER:		
NEXT ASSY:		CUSTOMER:		
		SIZE	TYPE	DWG NO.
			C-	P28968
		SCALE	HALF	SHEET 1 OF 1
				REVISION B1

TITLE: M35 PB LITE, 4 PIN, REDUCING TEE, BLACK
 DWG NO: C-P28968
 REV: B1
 SH: 1
 OF: 1