

THIS DRAWING IS UNPUBLISHED.		RELEASED FOR PUBLICATION	
COPYRIGHT - By - ALL RIGHTS RESERVED.			
PART NUMBER	REV	FIRST USED	
687392-9	M	354500-1	

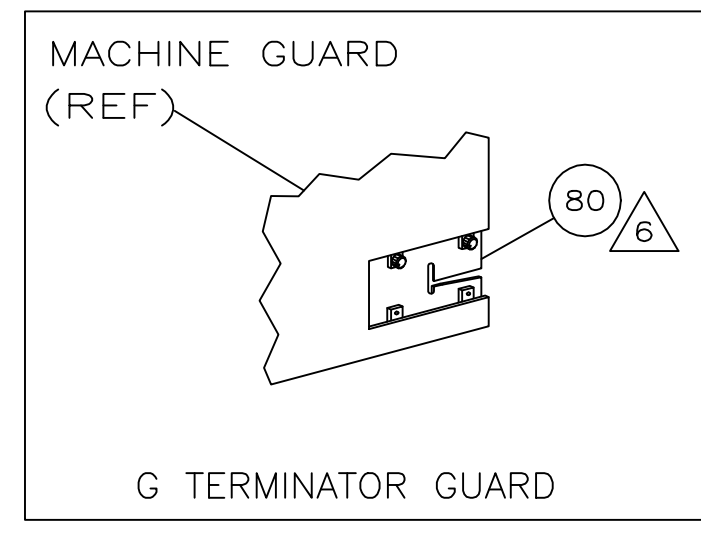

687392-9.B.SH1 .187 & .205 FLAG FASTON™ TERMINAL			
CRIMPING DATA			
PAD LTR	CRIMP HEIGHT	WIRE SIZE	
A	.040±.002 [1.01±0.05mm]	16	
B	.037±.002 [0.94±0.05mm]	18	
C	.035±.002 [0.89±0.05mm]	20	
D	NOT USED		
CRIMP	SIZE	TYPE	RANGE
WIRE	.140 [3.56mm]	TAB LOCK	20-16
INSUL	.140 [3.56mm]	0	.110-.170

REVISIONS				
P	LTR	DESCRIPTION	DATE	APPD
M		ECR-17-003359	20DEC2016	KH CT
M1		ECR-19-000807	17JAN2019	GK GB

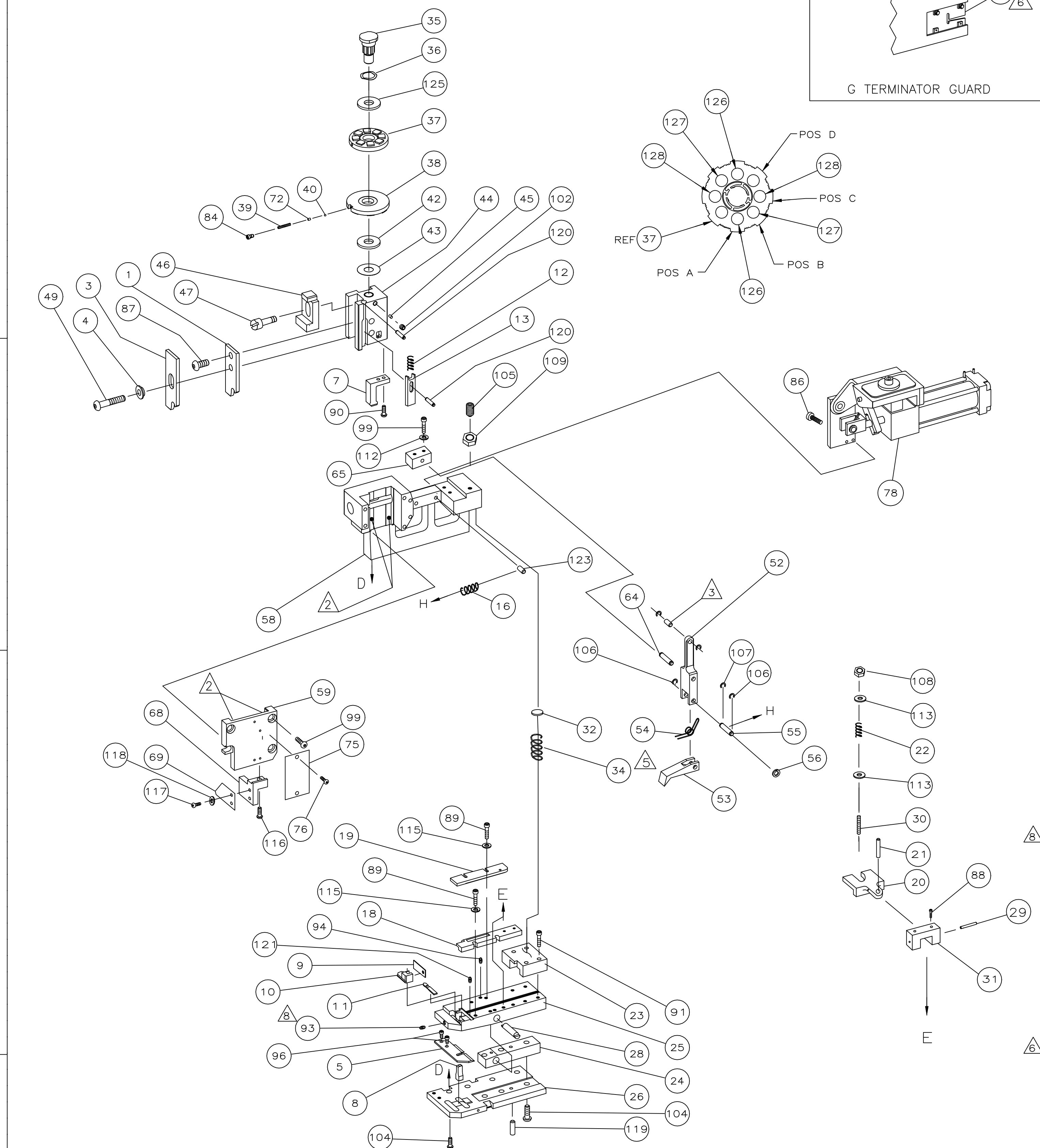

QTY REQD PER ASSY	U/M	DWG SIZE	PART NO	DESCRIPTION	ITEM NO
1	-	-	5-354779-2	PIN, WIRE DISC (.3250)C	128
2	-	C	4-354779-8	PIN, WIRE DISC (.3230)B	127
2	-	C	4-354779-4	PIN, WIRE DISC (.3210)A	126
1	-	A	986950-1	WASHER, FLAT PRECISION	125
1	-	A	3-22183-9	PIN, GROOVED(.187 X 1.25)	123
2	-	A	3-21028-2	PIN, SLOTTED SPRING (Ø094X.25)	121
2	-	A	4-21028-9	PIN, SLOTTED SPRING (Ø125X.38)	120
1	-	A	21029-5	PIN,SLOTTED SPRING (Ø188X.75)	119
2	-	A	21024-3	WASHER, LOCK (#6)	118
2	-	A	1-21000-8	SCREW,SHC(6-32X.25)STOP	117
1	-	A	2-22603-0	SCREW,SHC(8-32X.38)MTG	116
4	-	A	21024-4	WASHER, LOCK (#8)	115
2	-	A	21055-6	WASHER, FLAT (#8)	114
2	-	A	21899-2	WASHER,FLAT (#10)	113
2	-	A	21024-5	WASHER, LOCK (#10)	112
1	-	A	1-22202-7	NUT, HEX (5/16-24)	109
1	-	A	21022-3	NUT,HEX(LOCKING) (10-32)	108
1	-	A	1-21986-2	RING,RET "E" Ø5/16	107
2	-	A	21045-3	RING,RET "C" Ø5/16	106
1	-	A	8-21007-5	SCREW,SKT SET(5/16-24X.75)	105
7	-	A	2-22733-8	SCREW, BHC (1/4-20X.63)	104
1	-	A	21009-2	SCREW,SKT SET(1/4-20X.25)	102
2	-	A	3-21000-9	SCREW, SHC (10-32X1.00)	100
6	-	A	3-21000-8	SCREW, SHC (10-32X.88)	99
1	-	A	3-21000-6	SCREW, SHC (10-32X.62)	98
2	-	A	7-21000-6	SCREW, SHC (10-32X.38)	96
1	-	A	4-21006-5	SCREW, SKT SET (8-32X.62)	94
1	-	A	21061-9	SCREW, SKT SET (8-32X.25)	93
4	-	A	2-21000-9	SCREW, SHC (8-32X.75)	91
2	-	A	1-23030-1	SCREW, SHC (NYLOK)(8-32X.62)	90
4	-	A	2-22603-3	SCREW, SHC (8-32X.62)	89
2	-	A	2-21000-8	SCREW, SHC (8-32X.62)	88
1	-	A	2-21002-1	SCREW, SBHC (8-32X.38)	87
2	-	A	21001-3	SCREW,SHC (1/4-20X.62)	86
1	-	A	23030-1	SCREW, SHC(NYLOK)(6-32X.25)	84
1	-	A	679532-1	INSERT, GUARD	80
1	-	D	462622-2	AIR FEED ASSEMBLY	78
2	-	A	21017-2	SCR,DRIVE(#2X.19)ID	76
1	-	B	461264-1	PLATE, IDENTIFICATION	75
1	-	A	690603-1	SPRING, ASSIST	72
1	-	A	690716-3	CRIMPER, WIRE	1

QTY REQD PER ASSY	U/M	DWG SIZE	PART NO	DESCRIPTION	ITEM NO
1	-	B	318530-2	STOP, WIRE	69
1	-	B	318529-1	BLOCK, HOUSING	68
1	-	B	456987-1	BLOCK, PIVOT	65
1	-	A	457058-1	PIN, PIVOT	64
1	-	C	318528-1	CAP, RAM	59
1	-	D	457079-1	HOUSING	58
1	-	B	25745-1	RING, SPLIT	56
1	-	B	240624-1	PIN, FEED FINGER	55
1	-	B	691499-1	SPRING, FEED FINGER	54
1	-	B	454568-2	FINGER, FEED	53
1	-	B	457057-1	ARM, PIVOT	52
1	-	A	3-21002-5	BOLT, CRIMPER	49
1	-	A	22353-8	SCREW, SHOULDER	47
1	-	A	690578-1	BLOCK, INSULATION ADJUST	46
1	-	A	690191-1	PLUG, NYLON	45
1	-	C	454574-1	RAM	44
1	-	A	690125-1	WASHER, LAMINATED	43
1	-	A	1-690124-1	WASHER, RAM	42
1	-	A	23241-6	BALL, STEEL	40
1	-	A	690170-1	SPRING, COMPRESSION	39
1	-	C	690142-1	DISC, INSULATION	38
1	-	D	354777-1	WIRE DISC, PLASTIC	37
1	-	B	22480-5	WASHER, SPRING	36
1	-	B	690212-1	POST, RAM	35
1	-	A	3-23846-5	SPRING, HINGE BAR	34
1	-	A	690573-1	SPACER, SPRING	32
1	-	B	454569-1	DRAG MOUNT	31
1	-	A	1-22354-8	STUD, DRAG	30
1	-	B	21030-2	PIN, DRAG MOUNT	29
1	-	B	1633530-1	PIN, HINGE	28
1	-	C	684905-1	PLATE, BASE	26
1	-	B	454579-2	HINGE BAR	25
1	-	B	690571-1	BLOCK, STABILIZER	24
1	-	C	690585-1	BLOCK, PRESSURE	23
1	-	A	22282-5	SPRING, DRAG	22
1	-	A	21030-6	LEVER, DRAG	21
1	-	A	454570-1	DRAG, STOCK	20
1	-	C	454573-1	GUIDE, STRIP (REAR)	19
1	-	B	318739-8	GUIDE, STRIP (FRONT)	18
1	-	A	2-22287-6	SPRING, FEED RETURN	16
1	-	C	692134-7	POSITIONER, TERMINAL	13
1	-	A	5-22280-5	SPRING,TERM. POSITIONER	12
1	-	B	454712-4	PLATE, REAR SHEAR	11
1	-	C	454578-1	ANVIL INSERT	10
1	-	B	690569-2	PLATE, FRONT SHEAR	9
1	-	D	690718-1	ANVIL	8
1	-	B	454575-3	BLADE, SLUG	7
1	-	B	684906-1	PLATE,ANVIL RETAINING	5
1	-	B	690574-1	SPACER,TUBULAR INSUL CRIMPER	4
1	-	C	690715-1	CRIMPER, INSULATION	3

- 1 RECOMMENDED SPARE PARTS.
- 2 GREASE LIGHTLY.
- 3 LUBRICATE DAILY USING NO. 20 MACHINE OIL.
- 4 CHANGE TERMINAL POSITIONER AS REQUIRED TO KEEP TERMINAL ON CENTER OF ANVIL.FASTEN EXTRA TERMINAL POSITIONER TO APPLICATOR.
- 5 AFTER ASSEMBLY OF APPLICATOR, PROPER SPRING PRESSURE (ITEM 34) CAN BE OBTAINED BY TIGHTENING SET SCREW (ITEM 105) UNTIL CONTACT IS MADE WITH SPACER (ITEM 32) THEN TIGHTEN AN ADDITIONAL 5 1/2 - 6 REVOLUTIONS.

- 6 GUARD MUST BE IN PLACE WHEN OPERATING APPLICATOR IN A BENCH MACHINE
- 7 WIRE STRIP LENGTH .205 SERIES .205-.235 .187 SERIES .173-.203
- 8 APPLY SEALANT 1-23419-5 AT ASSEMBLY.

QTY REQD PER ASSY	U/M	DWG SIZE	PART NO	DESCRIPTION	ITEM NO
1	-	-	690716-3	CRIMPER, WIRE	1

QTY REQD PER ASSY	U/M	DWG SIZE	PART NO	DESCRIPTION	ITEM NO
1	-	-	690716-3	CRIMPER, WIRE	1

THIS DRAWING IS A CONTROLLED DOCUMENT.

APPROVED: P. MATHIAS (2-23-96), C. ERISMAN (2-26-96), T. FELBIN (2-26-96)

NAME: END FEED HINGE BAR APPLICATOR

PRODUCT SPEC: -

APPLICATION SPEC: -

SIZE: A1, CAGE CODE: 00779, DRAWING NO: 687392-9

RESTRICTED TO: -

CUSTOMER DRAWING, SCALE: NTS, SHEET 1 OF 1, REV M1