



SPECIFICATION SHEET

SPECIFICATION SHEET NO.	P1125- RD335M400HFCBA
DATE	Nov.25, 2022
REVISION	A1
DESCRIPTION	Through Hole High Ripple Current Aluminum Electrolytic Capacitors, Radial Type RD series, 2 Pins, Capacitance: 3.3μF, Tolerance ±20%, Voltage 400V, Case size: Ø8*L12mm, Ripple Current 110mA Max. Load Life: 8000 Hours, Sleeve: PET, Operating Temp. Range -40°C ~+105°C RoHS/RoHS III Compliant & Halogen Free Package in Bulk, 500pcs/Bag
CUSTOMER	
CUSTOMER PART NUMBER	
CROSS REF. PART NUMBER	
ORIGINAL PART NUMBER	Aillen CBE335M2GHRDF12RR
PART CODE	RD335M400HFCBA

VENDOR APPROVE			
Issued/Checked/Approved			
DATE: Nov.25, 2022			

CUSTOMER APPROVE	
DATE:	

11/25/2022

DIP ALUMINUM ELECTROLYTIC CAPACITORS RD SERIES

MAIN FEATURE

- Through Hole High Ripple Current Aluminum Electrolytic Capacitors, Radial Type
- Long Load Life
- High Working Voltage and High Ripple Current
- RoHS Complaint And Halogen Free
- Tape Package And Lead Cut 3.5~7.0mm Optional



APPLICATION

- For High Frequency Circuits Such As LED Circuit, Switching Power Supply, Main Board (Voltage Regulation Module) Circuit, Frequency Converter Circuit, Etc.

RFQ

[Request For Quotation](#)

PART CODE GUIDE

RD	335	M	400	H	F	C	B	A
1	2	3	4	5	6	7	8	9

1) **RD**: Through Hole High Ripple Current Aluminum Electrolytic Capacitors, Radial Type, RD series

2) **335**: Rated Capacitance Code, 105: 1.0 μ F; 225: 2.2 μ F; **335: 3.3 μ F**; 475: 4.7 μ F; 685: 6.8 μ F; 106: 10 μ F; 226: 22 μ F; 336: 33 μ F;
476: 47 μ F; 686: 68 μ F; 107: 100 μ F; 227: 220 μ F; 337: 330 μ F; 477: 470 μ F

3) **M**: Capacitance tolerance code, **M: \pm 20%**; V: -10% ~ \pm 20%; R: -0 ~ \pm 20%

4) **400**: Rated Voltage Code, 6V3: 6.3V; 010: 10V; 016:16V; 025: 25V; 035: 35V; 050: 50V; 063: 63V; 100: 100V; 160: 160V
200: 200V; 250: 250V; 350: 350V; **400: 400V**; 450V: 450V

5) **H**: Environmental Requirements code, R: RoHS Complaint; **H: RoHS III Complaint & Halogen Free**

6) **F**: Aluminum Case size code, B: \varnothing 3.0mm C: \varnothing 4.0mm D: \varnothing 5.0mm; E: \varnothing 6.3mm; **F: \varnothing 8.0mm**; G: \varnothing 10.0mm; I: \varnothing 12.5mm;
J: \varnothing 13.0mm;K: \varnothing 16.0mm, L: \varnothing 18.0mm; N: \varnothing 22.0mm

7) **C**: Aluminum case Height code, 7: L7.0mm; A: L11mm; B: L11.5mm; **C: L12mm**; D: L12.5mm; E: L20mm; F: L21.5mm;
G: L31.5mm; H: 16mm

8) **B**: Package in Bulk, 500pcs/Bag

9) **A**: Internal control or Special Code (A~Z or 1~9)

DIP ALUMINUM ELECTROLYTIC CAPACITORS RD SERIES

Image for reference

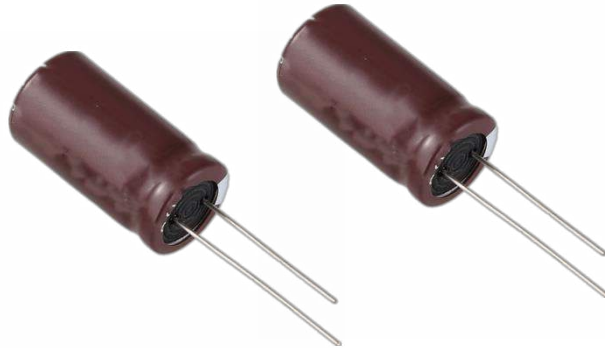

RD Series
Case $\phi 8 * L12\text{mm}$

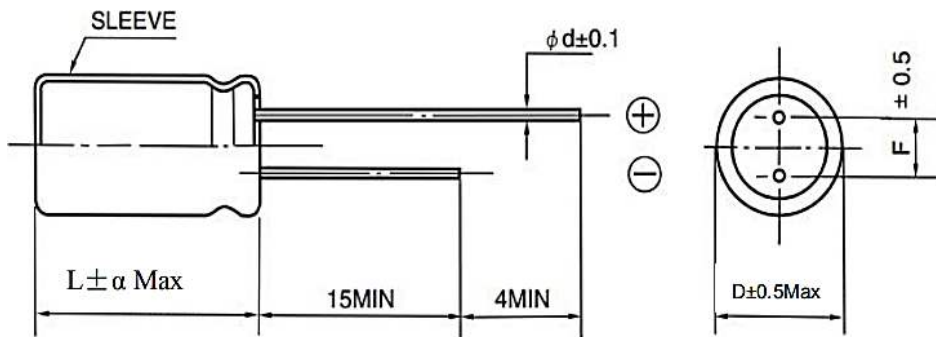

Symbol	Dimension (mm)
D	$\phi 8.0$
F	3.5
d	$\phi 0.50$
L	$12.0 + / - \alpha$
α	1.5

DIP ALUMINUM ELECTROLYTIC CAPACITORS RD SERIES

CONSTRUCTION

Single ended type to be produced to fix the terminals to anode and cathode foil, and wind together with paper, and then wound element to be impregnated with electrolyte will be enclosed in an aluminum case. Finally sealed up tightly with end seal rubber, then finished by putting on the vinyl sleeve.

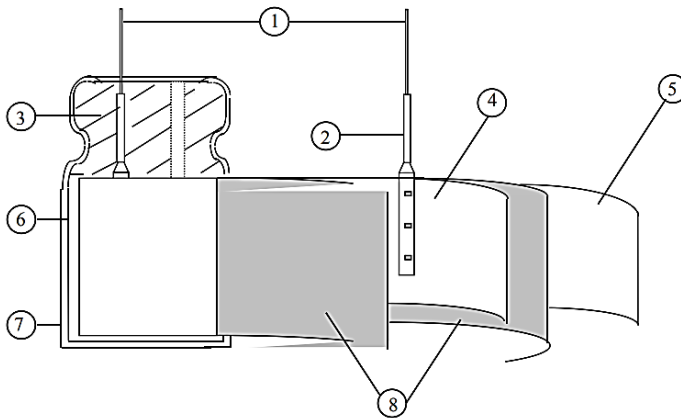

No.	Component	Material
1	Lead Line	Tinned CP Wire (Pb Free)
2	Terminal	Aluminum Wire
3	Sealing Material	Rubber
4	Al-Foil (+)	Formed Aluminum Foil
5	Al-Foil (-)	Etched aluminum foil or formed Aluminum Foil
6	Case	Aluminum case
7	Sleeve	PET
8	Separator	Electrolyte paper

DIP ALUMINUM ELECTROLYTIC CAPACITORS RD SERIES

CHARACTERISTICS

Standard atmospheric conditions

The standard range of atmospheric conditions for making measurements/test as follows:

Ambient temperature: 15°C to 35°C

Relative humidity: 45% to 85%

Air Pressure: 86kPa to 106kPa

If there is any doubt about the results, measurement shall be made within the following conditions:

Ambient temperature: 20°C ± 2°C

Relative humidity: 60% to 70%

Air Pressure: 86kPa to 106kPa

As to the detailed information, please refer to following Table 1 and Table 2

Table 1

ITEM	CHARACTERISTICS
Operating Temperature Range	-40~+105°C
Rated Voltage Range	400 V
Capacitance Range	3.3 μF
Capacitance Tolerance at 20°C, 120Hz	± 20%

DIP ALUMINUM ELECTROLYTIC CAPACITORS RD SERIES

Table 2

ITEM	CHARACTERISTICS																																
Rated Voltage (WV)/Surge Voltage (SV)	<table border="1" data-bbox="458 430 1286 675"> <tr> <td>WV</td> <td>6.3</td> <td>10</td> <td>16</td> <td>25</td> <td>35</td> <td>50</td> <td>63</td> </tr> <tr> <td>SV</td> <td>-</td> <td>-</td> <td>-</td> <td>-</td> <td>-</td> <td>-</td> <td>-</td> </tr> <tr> <td>WV</td> <td>160</td> <td>200</td> <td>250</td> <td>350</td> <td>400</td> <td>450</td> <td>500</td> </tr> <tr> <td>SV</td> <td>200</td> <td>250</td> <td>300</td> <td>400</td> <td>450</td> <td>500</td> <td>550</td> </tr> </table>	WV	6.3	10	16	25	35	50	63	SV	-	-	-	-	-	-	-	WV	160	200	250	350	400	450	500	SV	200	250	300	400	450	500	550
WV	6.3	10	16	25	35	50	63																										
SV	-	-	-	-	-	-	-																										
WV	160	200	250	350	400	450	500																										
SV	200	250	300	400	450	500	550																										
Nominal capacitance (Tolerance)	<p><Condition> Measuring Frequency : 120Hz±12Hz Measuring Voltage : Not more than 0.5Vrms Measuring Temperature : 20±2°C</p> <p><Criteria> Shall be within the specified capacitance tolerance</p>																																
Leakage current	<p><Condition> Connecting the capacitor with a protective resistor (1kΩ±10Ω) in series for 2 minutes, and then, measure leakage current.</p> <p><Criteria> 160V~500V: I (μA)≤0.02CV + 40 (μA) I: Leakage current (μA) C: Capacitance (μF) V: Rated DC working voltage (V)</p>																																
tanδ	<p><Condition> See Nominal capacitance, for measuring frequency, voltage and temperature.</p> <p><Criteria></p> <table border="1" data-bbox="458 1583 1300 1810"> <tr> <td>W.V(V)</td> <td>6.3</td> <td>10</td> <td>16</td> <td>25</td> <td>35</td> <td>50</td> <td>63</td> </tr> <tr> <td>Tan δ Max.</td> <td>-</td> <td>-</td> <td>-</td> <td>-</td> <td>-</td> <td>-</td> <td>-</td> </tr> <tr> <td>W.V(V)</td> <td>160</td> <td>200</td> <td>250</td> <td>350</td> <td>400</td> <td>450</td> <td>500</td> </tr> <tr> <td>Tan δ Max.</td> <td>0.15</td> <td>0.15</td> <td>0.15</td> <td>0.20</td> <td>0.20</td> <td>0.20</td> <td>0.20</td> </tr> </table>	W.V(V)	6.3	10	16	25	35	50	63	Tan δ Max.	-	-	-	-	-	-	-	W.V(V)	160	200	250	350	400	450	500	Tan δ Max.	0.15	0.15	0.15	0.20	0.20	0.20	0.20
W.V(V)	6.3	10	16	25	35	50	63																										
Tan δ Max.	-	-	-	-	-	-	-																										
W.V(V)	160	200	250	350	400	450	500																										
Tan δ Max.	0.15	0.15	0.15	0.20	0.20	0.20	0.20																										

DIP ALUMINUM ELECTROLYTIC CAPACITORS RD SERIES

ITEM	CHARACTERISTICS																																		
Terminal strength	<p><Condition></p> <p>Tensile strength of terminals Fixed the capacitor, applied force to the terminal in lead out direction for 10 ± 1 seconds. Bending strength of terminals. Fixed the capacitor, applied force to bent the terminal (1~4 mm from the rubber) for 90o within 2~3 seconds, and then bent it for 90o to its original position within 2~3 seconds.</p> <table border="1" data-bbox="458 685 1300 841"> <thead> <tr> <th>Diameter of lead wire</th> <th>Tensile force N (kgf)</th> <th>Bending force N (kgf)</th> </tr> </thead> <tbody> <tr> <td>0.5mm and less</td> <td>5 (0.51)</td> <td>2.5 (0.25)</td> </tr> <tr> <td>Over 0.5mm to 0.8mm</td> <td>10 (1.0)</td> <td>5 (0.51)</td> </tr> </tbody> </table> <p><Criteria></p> <p>No noticeable changes shall be found, no breakage or looseness at the terminal</p>	Diameter of lead wire	Tensile force N (kgf)	Bending force N (kgf)	0.5mm and less	5 (0.51)	2.5 (0.25)	Over 0.5mm to 0.8mm	10 (1.0)	5 (0.51)																									
Diameter of lead wire	Tensile force N (kgf)	Bending force N (kgf)																																	
0.5mm and less	5 (0.51)	2.5 (0.25)																																	
Over 0.5mm to 0.8mm	10 (1.0)	5 (0.51)																																	
Temperature characteristics	<p><Condition></p> <table border="1" data-bbox="458 1017 1300 1324"> <thead> <tr> <th>Step</th> <th>Testing temperature(°C)</th> <th>Time</th> </tr> </thead> <tbody> <tr> <td>1</td> <td>20 ± 2</td> <td>Time to reach thermal equilibrium</td> </tr> <tr> <td>2</td> <td>$(-40) -25 \pm 3$</td> <td>Time to reach thermal equilibrium</td> </tr> <tr> <td>3</td> <td>20 ± 2</td> <td>Time to reach thermal equilibrium</td> </tr> <tr> <td>4</td> <td>105 ± 2</td> <td>Time to reach thermal equilibrium</td> </tr> <tr> <td>5</td> <td>20 ± 2</td> <td>Time to reach thermal equilibrium</td> </tr> </tbody> </table> <p><Criteria></p> <p>a. At +105°C: capacitance measured shall be within $\pm 20\%$ of its original value at +20°C: $\tan \delta$ shall be within the limit of $\tan \delta$, The leakage current measured shall not more than 8 times of its specified value.</p> <p>b. In step 5, $\tan \delta$ shall be within the limit of $\tan \delta$, The leakage current shall not more than the specified value.</p> <p>c. At-25 °C : Impedance (Z) ratio shall not exceed the value of the following table.</p> <table border="1" data-bbox="444 1721 1300 1846"> <thead> <tr> <th>Rated Voltage (V)</th> <th>160</th> <th>200</th> <th>300</th> <th>350</th> <th>400</th> <th>450</th> <th>500</th> </tr> </thead> <tbody> <tr> <td>Z-25°C/ Z +20°C</td> <td>3</td> <td>3</td> <td>3</td> <td>5</td> <td>5</td> <td>6</td> <td>12</td> </tr> </tbody> </table> <p>Capacitance, $\tan \delta$, and impedance shall be measured at 120Hz.</p>	Step	Testing temperature(°C)	Time	1	20 ± 2	Time to reach thermal equilibrium	2	$(-40) -25 \pm 3$	Time to reach thermal equilibrium	3	20 ± 2	Time to reach thermal equilibrium	4	105 ± 2	Time to reach thermal equilibrium	5	20 ± 2	Time to reach thermal equilibrium	Rated Voltage (V)	160	200	300	350	400	450	500	Z-25°C/ Z +20°C	3	3	3	5	5	6	12
Step	Testing temperature(°C)	Time																																	
1	20 ± 2	Time to reach thermal equilibrium																																	
2	$(-40) -25 \pm 3$	Time to reach thermal equilibrium																																	
3	20 ± 2	Time to reach thermal equilibrium																																	
4	105 ± 2	Time to reach thermal equilibrium																																	
5	20 ± 2	Time to reach thermal equilibrium																																	
Rated Voltage (V)	160	200	300	350	400	450	500																												
Z-25°C/ Z +20°C	3	3	3	5	5	6	12																												

DIP ALUMINUM ELECTROLYTIC CAPACITORS RD SERIES

ITEM	CHARACTERISTICS								
Load life test	<p><Condition></p> <p>According to IEC60384-4 No.4.13 methods, The capacitor is stored at a temperature of $105 \pm 2^\circ \text{C}$ with DC bias voltage plus the rated ripple current for 2000+48/0 hours. (The sum of DC and ripple peak voltage shall not exceed the rated working voltage)</p> <p>Then the product should be tested after 16 hours recovering time at atmospheric conditions. The result should meet the following table:</p> <p><Criteria></p> <p>The characteristic shall meet the following requirements.</p> <table border="1" data-bbox="458 779 1300 988"> <tr> <td>Leakage current</td> <td>Value in 4.3 shall be satisfied</td> </tr> <tr> <td>Capacitance Change</td> <td>Within $\pm 20\%$ of initial value</td> </tr> <tr> <td>$\tan\delta$</td> <td>Not more than 200% of the specified value.</td> </tr> <tr> <td>Appearance</td> <td>There shall be no leakage of electrolyte.</td> </tr> </table>	Leakage current	Value in 4.3 shall be satisfied	Capacitance Change	Within $\pm 20\%$ of initial value	$\tan\delta$	Not more than 200% of the specified value.	Appearance	There shall be no leakage of electrolyte.
Leakage current	Value in 4.3 shall be satisfied								
Capacitance Change	Within $\pm 20\%$ of initial value								
$\tan\delta$	Not more than 200% of the specified value.								
Appearance	There shall be no leakage of electrolyte.								
Shelf life test	<p><Condition></p> <p>The capacitors are then stored with no voltage applied at a temperature of $105 \pm 2^\circ \text{C}$ for 1000+48/0 hours. Following this period the capacitors shall be removed from the test chamber and be allowed to stabilized at room temperature for 4~8 hours. Next they shall be connected to a series limiting resistor($1k \pm 100\Omega$) with D.C. rated voltage applied for 30min. After which the capacitors shall be discharged, and then, tested the characteristics.</p> <p><Criteria></p> <p>The characteristic shall meet the following requirements.</p> <table border="1" data-bbox="458 1498 1300 1707"> <tr> <td>Leakage current</td> <td>Value in 4.3 shall be satisfied</td> </tr> <tr> <td>Capacitance Change</td> <td>Within $\pm 20\%$ of initial value</td> </tr> <tr> <td>$\tan\delta$</td> <td>Not more than 200%of the specified value.</td> </tr> <tr> <td>Appearance</td> <td>There shall be no leakage of electrolyte.</td> </tr> </table> <p>Remark: If the capacitors are stored more than 1 year, the leakage current may increase. Please apply voltage through about 1 K Ω resistor, if necessary.</p>	Leakage current	Value in 4.3 shall be satisfied	Capacitance Change	Within $\pm 20\%$ of initial value	$\tan\delta$	Not more than 200%of the specified value.	Appearance	There shall be no leakage of electrolyte.
Leakage current	Value in 4.3 shall be satisfied								
Capacitance Change	Within $\pm 20\%$ of initial value								
$\tan\delta$	Not more than 200%of the specified value.								
Appearance	There shall be no leakage of electrolyte.								

DIP ALUMINUM ELECTROLYTIC CAPACITORS RD SERIES

ITEM	CHARACTERISTICS								
Surge test	<p><Condition></p> <p>Applied a surge voltage to the capacitor connected with a $(100 \pm 50)/CR$ (KΩ) resistor. The capacitor shall be submitted to 1000 cycles, each consisting of charge of $30 \pm 5s$, followed discharge of 5 min 30s. The test temperature shall be 15~35°C. CR :Nominal Capacitance (μF)</p> <p><Criteria></p> <table border="1" data-bbox="458 689 1300 899"> <tr> <td>Leakage current</td> <td>Not more than the specified value</td> </tr> <tr> <td>Capacitance Change</td> <td>Within $\pm 15\%$ of initial value</td> </tr> <tr> <td>$\tan\delta$</td> <td>Not more than the specified value</td> </tr> <tr> <td>Appearance</td> <td>There shall be no leakage of electrolyte.</td> </tr> </table> <p>Attention: This test simulates over voltage at abnormal situation only. It is not applicable to such over voltage as often applied.</p>	Leakage current	Not more than the specified value	Capacitance Change	Within $\pm 15\%$ of initial value	$\tan\delta$	Not more than the specified value	Appearance	There shall be no leakage of electrolyte.
Leakage current	Not more than the specified value								
Capacitance Change	Within $\pm 15\%$ of initial value								
$\tan\delta$	Not more than the specified value								
Appearance	There shall be no leakage of electrolyte.								
Solderability test	<p><Condition></p> <p>The capacitor shall be tested under the following conditions: Soldering temperature : $245\pm 3^\circ C$</p> <p>Dipping depth : 2mm</p> <p>Dipping speed : $25\pm 2.5mm/s$</p> <p>Dipping time : $3\pm 0.5s$ <Criteria></p> <p><Criteria></p> <p>Coating quality : A minimum of 95% of the surface being immersed</p>								

DIP ALUMINUM ELECTROLYTIC CAPACITORS RD SERIES

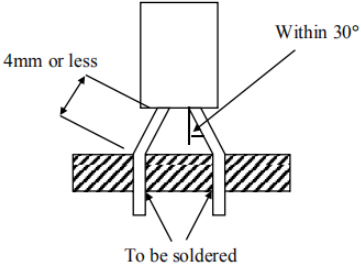
ITEM	CHARACTERISTICS								
Vibration test	<p><Condition></p> <p>The following conditions shall be applied for 2 hours in each 3 mutually perpendicular directions.</p> <p>Vibration frequency range : 10Hz ~ 55Hz</p> <p>Peak to peak amplitude : 1.5mm</p> <p>Sweep rate : 10Hz ~ 55Hz ~ 10Hz in about 1 minute</p> <p>Mounting method: The capacitor with diameter greater than 12.5mm or longer than 25mm must be fixed in place with a bracket.</p>  <p><Criteria> After the test, the following items shall be tested:</p> <table border="1" data-bbox="458 1116 1300 1313"> <tr> <td data-bbox="458 1116 696 1197">Inner construction</td> <td data-bbox="696 1116 1300 1197">No intermittent contacts, open or short circuiting. No damage of tab terminals or electrodes</td> </tr> <tr> <td data-bbox="458 1197 696 1313">Appearance</td> <td data-bbox="696 1197 1300 1313">No mechanical damage in terminal. No leakage of electrolyte or swelling of the case. The markings shall be legible</td> </tr> </table>	Inner construction	No intermittent contacts, open or short circuiting. No damage of tab terminals or electrodes	Appearance	No mechanical damage in terminal. No leakage of electrolyte or swelling of the case. The markings shall be legible				
Inner construction	No intermittent contacts, open or short circuiting. No damage of tab terminals or electrodes								
Appearance	No mechanical damage in terminal. No leakage of electrolyte or swelling of the case. The markings shall be legible								
Resistance to solder heat test	<p><Condition></p> <p>Terminals of the capacitor shall be immersed into solder bath at $260\pm 5^{\circ}\text{C}$ for 10 ± 1 seconds or $400\pm 10^{\circ}\text{C}$ for 30 seconds to 1.5~2.0mm from the body of capacitor. Then the capacitor shall be left under the normal temperature and normal humidity for 1~2 hours before measurement.</p> <p><Criteria></p> <table border="1" data-bbox="462 1680 1305 1887"> <tr> <td data-bbox="462 1680 768 1736">Leakage current</td> <td data-bbox="768 1680 1305 1736">Not more than the specified value</td> </tr> <tr> <td data-bbox="462 1736 768 1783">Capacitance Change</td> <td data-bbox="768 1736 1305 1783">Within $\pm 10\%$ of initial value</td> </tr> <tr> <td data-bbox="462 1783 768 1835">$\tan\delta$</td> <td data-bbox="768 1783 1305 1835">Not more than the specified value</td> </tr> <tr> <td data-bbox="462 1835 768 1887">Appearance</td> <td data-bbox="768 1835 1305 1887">There shall be no leakage of electrolyte.</td> </tr> </table>	Leakage current	Not more than the specified value	Capacitance Change	Within $\pm 10\%$ of initial value	$\tan\delta$	Not more than the specified value	Appearance	There shall be no leakage of electrolyte.
Leakage current	Not more than the specified value								
Capacitance Change	Within $\pm 10\%$ of initial value								
$\tan\delta$	Not more than the specified value								
Appearance	There shall be no leakage of electrolyte.								

DIP ALUMINUM ELECTROLYTIC CAPACITORS RD SERIES

ITEM	CHARACTERISTICS																
<p>Change of temperature test</p>	<p><Condition> Temperature cycle: According to IEC60384-4 No.4.7 methods, capacitor shall be placed in an oven, the condition according as below:</p> <table border="1" data-bbox="458 493 1300 752"> <thead> <tr> <th>Temperature</th> <th>Time</th> </tr> </thead> <tbody> <tr> <td>(1)+20°C</td> <td>≤ 3 Minutes</td> </tr> <tr> <td>(2)-40°C</td> <td>30 ± 2 Minutes</td> </tr> <tr> <td>(3)+105°C</td> <td>30 ± 2 Minutes</td> </tr> <tr> <td colspan="2" style="text-align: center;">(1) To (3) = 1 cycle, Total 5 Cycles</td> </tr> </tbody> </table> <p><Criteria> The characteristic shall meet the following requirement.</p> <table border="1" data-bbox="458 866 1300 1023"> <tbody> <tr> <td>Leakage current</td> <td>Not more than the specified value.</td> </tr> <tr> <td>Tan δ</td> <td>Not more than the specified value.</td> </tr> <tr> <td>Appearance</td> <td>There shall be no leakage of electrolyte.</td> </tr> </tbody> </table>	Temperature	Time	(1)+20°C	≤ 3 Minutes	(2)-40°C	30 ± 2 Minutes	(3)+105°C	30 ± 2 Minutes	(1) To (3) = 1 cycle, Total 5 Cycles		Leakage current	Not more than the specified value.	Tan δ	Not more than the specified value.	Appearance	There shall be no leakage of electrolyte.
Temperature	Time																
(1)+20°C	≤ 3 Minutes																
(2)-40°C	30 ± 2 Minutes																
(3)+105°C	30 ± 2 Minutes																
(1) To (3) = 1 cycle, Total 5 Cycles																	
Leakage current	Not more than the specified value.																
Tan δ	Not more than the specified value.																
Appearance	There shall be no leakage of electrolyte.																
<p>Damp heat test</p>	<p><Condition> Humidity test: According to IEC60384-4 No.4.12 methods, capacitor shall be exposed for 500±8 hours in an atmosphere of 90~95%R H .at 40±2°C, the characteristic change shall meet the following requirement.</p> <p><Criteria></p> <table border="1" data-bbox="465 1290 1308 1500"> <tbody> <tr> <td>Leakage current</td> <td>Not more than the specified value.</td> </tr> <tr> <td>Capacitance Change</td> <td>Within ± 20% of initial value..</td> </tr> <tr> <td>Tan δ</td> <td>Not more than 120% of the specified value.</td> </tr> <tr> <td>Appearance</td> <td>There shall be no leakage of electrolyte.</td> </tr> </tbody> </table>	Leakage current	Not more than the specified value.	Capacitance Change	Within ± 20% of initial value..	Tan δ	Not more than 120% of the specified value.	Appearance	There shall be no leakage of electrolyte.								
Leakage current	Not more than the specified value.																
Capacitance Change	Within ± 20% of initial value..																
Tan δ	Not more than 120% of the specified value.																
Appearance	There shall be no leakage of electrolyte.																
<p>Vent test</p>	<p><Condition> The following test only apply to those products with vent products at diameter ≥Ø 6.3 with vent. D.C. test The capacitor is connected with its polarity reversed to a DC power source. Then a current selected from Table 2 is applied.</p> <table border="1" data-bbox="475 1736 1318 1839"> <thead> <tr> <th>Diameter (mm)</th> <th>DC Current (A)</th> </tr> </thead> <tbody> <tr> <td>22.4 or less</td> <td>1</td> </tr> </tbody> </table> <p><Criteria> The vent shall operate with no dangerous conditions such as flames or dispersion of pieces of the capacitor and/or case.</p>	Diameter (mm)	DC Current (A)	22.4 or less	1												
Diameter (mm)	DC Current (A)																
22.4 or less	1																

11/25/2022

DIP ALUMINUM ELECTROLYTIC CAPACITORS RD SERIES

CASE SIZE & MAX RIPPLE CURRENT

Rated Voltage (V)	Capacitance (Tol.+/-20%) (μF)	Case Size Ø*L (mm)	Surge Volt (V)	Tanδ @+105°C, 120Hz	Load Life (Hrs)	Ripple Current @+105°C, 100KHz (mA r.m.s.)
400	3.3	8*12	450	0.20	8000	110

FREQUENCY COEFFICIENT OF ALLOWABLE RIPPLE CURRENT

Cap.	Frequency	50Hz(60Hz)	120Hz	1KHz	10KHz	≥100kHz
3.3μF	Coefficient	-	0.20	0.40	0.80	1.0

Remark:

- 1) Specification are subject to change without notice should a safety or technical concern arise regarding the product ,please be sure to contact our sales offices
- 2) The sizes in the above table are all general specifications. If you need other specifications, please contact us .

DIP ALUMINUM ELECTROLYTIC CAPACITORS RD SERIES

ATTENTION

When using Aluminum Electrolytic Capacitor, please pay attention to the points listed below. If the following types of electrical loads are applied to Aluminum Electrolytic Capacitor, rapid deterioration of electrical property occurs:

- Reverse voltage
- Overvoltage exceeding rated working voltage
- Current exceeding rated ripple current
- Severe charging/discharging

At such time, severe heat is generated, gas electrolyte leaks from the sealed area, and pressure relief vent operates due to increase of internal pressure. In the worst case, explosion or ignition may occur, and along with destruction of the capacitor combustibles may burst out.

1. CAUTION DURING CIRCUIT DESIGN

1) OPERATIONAL ENCIRONMENT, MOUNTING ENVIRONMENT AND CONDITIONS Ensure that operational and mounting conditions follow the specified conditions detailed in the catalog and specification sheets

2) OPERATING TEMPERARURE, RIPPLE CURRENT AND LOAD LIFE.

Operating temperature and applied ripple current should be within the specified value in the catalog or specification sheets. Do not use Aluminum Electrolytic Capacitors at temperature which exceeds the specified category temperatures range. Do not apply excessive current to the capacitors, which exceeds the specified rated ripple current. During circuit design, please ensure that capacitors are selected to match with the lifetime requirements of the application

3) APPLICATION

Aluminum Electrolytic Capacitors are normally polarized. Reverse voltage or AC Voltage should not be applied. When polarity may flip over, non-polar type should be used, but the non-polar type cannot be used for AC. Standard Aluminum Electrolytic Capacitors are not suitable for rapid charge and discharge applications. Group in your area about specialty signed capacitors for rapid charge and discharge.

4) APPLIED COLTAGE

Do not exceed the rated voltage of capacitors

5) INSULATION

Aluminum Electrolytic Capacitors should be electrically isolated from the following. Aluminum case, cathode lead wire, anode lead wire and circuit pattern; Auxiliary terminals of snap-in type, anode terminal, outward terminals and circuit pattern. The PVC sleeve of Aluminum Electrolytic Capacitors is not recognized as an insulator, and therefore, the standard capacitor should not be used in a place where insulation function is needed. Please consult with Shanghai Suzuki Electronics or sales office of Suzuki Techno Group in your area, if you require a higher grade of insulating sleeve.

DIP ALUMINUM ELECTROLYTIC CAPACITORS RD SERIES

6) CONDITIONS OF USE

The following environments should be avoided when using Aluminum Electrolytic Capacitors. Damp conditions such as water, salt water or oil spray or fumes, high humidity or humidity condensation situations. Hazardous gas/fumes such as hydrogen sulfide, sulfurous acid gas, nitrous acid, chlorine gas, ammonia or bromine gas; Exposure of ozone, ultraviolet rays or radiation; Severe vibration or shock which exceeds the condition specified in the catalog or specification sheet.

7) CONSIDERATION TO ASSEMBLY CONDITION

In designing a circuit, the following matters should be ensured in advance to the capacitor's assembly on the printed circuit board (PC board). Design the appropriate hole spacing to match the lead pitch of capacitors; Do not locate any wiring and circuit patterns directly above the capacitor's vent; Ensure enough free space above the capacitor's vent. The recommended space is specified in the catalog or specification sheets; In case the capacitor's vent is facing the PC board, make a gas release hole on PC board. The sealing side of the screw terminal type should not face down in the application. When the capacitors are mounted horizontally, the anode screw terminals must be positioned at upper side..

8) CONSIDERATION TO CIRCUIT DESIGN

Any copper lines or circuit patterns should not be laid under the capacitor; Parts which radiate heat should not be placed close to the reverse side of the Aluminum Electrolytic Capacitors on the PC board.

9) OTHERS

Performance of electrical characteristics of Aluminum Electrolytic Capacitors is affected by variation of operating temperature and frequency. Consider this variation when designing the circuit. Excessive holes and connection hole between both sides on the PC board should be avoided around or under the mounting area of the Aluminum Electrolytic Capacitors on double sided or multilayer PC board. Torque of tightening screw terminals should not exceed the specified maximum value which is described in the catalog and specification sheets. Consider current balance when 2 or more Aluminum Electrolytic Capacitors are connected in parallel. Use bleeding resistors when 2 or more Aluminum Electrolytic Capacitors are connected in series. In this case, the resistors should be connected parallel to the capacitors.

2. CAUTION FOR ASSEMBLING CAPACITORS

1) CAUTION BEFORE ASSEMBLY

Aluminum Electrolytic Capacitors cannot be recycled after mounting and applying electricity in unit. The capacitors, which are removed from PC board for the purpose of measuring electrical characteristics at the periodical inspection, should only be recycled for the same position.; Aluminum Electrolytic Capacitors may accumulate charge naturally during storage. In this case, discharge through a 1KOHM resistor before use; Leakage current of Aluminum Electrolytic Capacitors may be increased during long storage time. In this case, the capacitors should be subject to voltage treatment through a 1KOHM resistor before use.

DIP ALUMINUM ELECTROLYTIC CAPACITORS RD SERIES

2) IN THE ASSEMBLY PROCESS-1

Ensure rated voltage and capacitance of the capacitors before mounting; Ensure capacitors polarity before mounting; Do not use a capacitor which has been dropped onto a hard surface; Do not use a capacitor with damaged or dented cased or seals.

3) IN THE ASSEMBLY PROCESS-2

Capacitors should be mounted after confirmation that hole spacing on PC board matches the lead pitch of the capacitors; The snap-in type of capacitors should be mounted firmly on the PC board without a gap between the capacitor body and the surface of PC board;. Avoid excessive force when clinching lead wire during auto-insertion process; Avoid excessive shock to capacitors by automatic inserting machine, during mounting, parts inspection or centering operations; Please utilize supporting material such as strap of adhesive to mount capacitors to PC board when it is anticipated that vibration or shock is applied.

4) SOLDERING

Soldering conditions (temperature and time) should be within the specified conditions which are described in the catalog or specification sheets; In case lead wire reforming is needed due to inappropriate pitch between capacitor and holes on PC board, stress to the capacitor should be avoided; In case of maintenance by soldering iron, if it is required to detach the capacitor, it should be removed from PC board after solder has melted sufficiently in order to reduce stress on the lead wires/terminals of the capacitor; Soldering iron should never touch the capacitor's body.

5) FLOW SOLDERING

Do not dip capacitor's body into melted solder. It should only be soldered on the reverse side of the PC board on which the capacitors are mounted; Soldering condition (preheat, soldering temperature, dipping time) should be within the specified standard which is described in the catalog or specification sheets; Flux should not be adhered to capacitor's body but only to its terminals; Other devices which are mounted close to capacitors should not touch the capacitors.

6) REFLOW SOLDERING

Reflow soldering conditions (preheat, soldering, temperature, reflow time) should follow the specified standard which is described in the catalog or specification sheets; Heating standard should depend on surface of the capacitor color or materials when infrared rays are used because the capacitor's heat absorption depends on the surface color or materials. Check heat condition; Standard Aluminum Electrolytic Capacitors cannot withstand two or more reflow processes.

7) HANDLING AFTER SOLDERING Do not bend or twist the capacitor's body after soldering on PC board; Do not pick-up or move PC board by holding the soldered capacitors; Do not hit the capacitors and isolate capacitors from the PC board or other device when stacking PC boards in store.

DIP ALUMINUM ELECTROLYTIC CAPACITORS RD SERIES

8) PC BOARD CLEANING

Standard Aluminum Electrolytic Capacitors should be free from halogenated solvents during PC board cleaning after soldering

9) ADHESIVES AND COATING MATERIALS

Do not use halogenated adhesives and coating materials to fix Aluminum Electrolytic Capacitors; Flux between the surface of the PC board and sealing of capacitors should be cleaned before using adhesives or coating materials; Solvents should be dried up before using adhesives or coating materials; Do not cover up all the sealing area of capacitors with adhesives or coating materials, make coverage only partial.

3. CAUTION DURING USE OF CAPACITORS IN SETS

- 1) Do not touch the terminals of capacitors;
- 2) Do not connect electrical terminals of the capacitors. Keep the capacitors free from conductive solution, such as acid, alkali and so on;
- 3) Ensure the operational environment of the equipment in which the capacitor has been built is within the specified condition mentioned in the catalog or specification sheets.

4. MAINTENANCE

- 1) Periodical inspection should be carried out for the capacitors, which are used with industrial equipment. Check the following points at the inspection.
- 2) Visual inspection to check pressure relief vent open or leakage of electrolyte.
- 3) Electrical characteristics: leakage current, capacitance, dissipation factor and the other points which are mentioned in the catalog or specification sheets.

5. EMERGENCY ACTION

- 1) If the pressure relief vent is open and some gas blows out from the capacitor, turn the main switch of the equipment off or pull out the plug from the power outlet immediately.
- 2) During pressure relief vent operation, extremely hot gas (over 100°C) may blow out from the vent area of the capacitors. So keep your face and skin away from capacitors during its operation. In case of eye contact, flush the open eye(s) with large amount of clean water immediately. In case of ingestion, gargle with water immediately, and do not swallow. Also do not touch electrolyte but wash skin with soap and water in case of skin contact.

6. STORAGE CONDITIO

- 1) Aluminum Electrolytic Capacitors should not be stored in high temperature or in high humidity. The suitable storage condition is 5°C-35°C, and less than 75% in relative humidity;
- 2) Aluminum Electrolytic Capacitors should not be stored in damp conditions such as water, salt water spray or oil spray;
- 3) Do not store Aluminum Electrolytic Capacitors in an environment full of hazardous gas (hydrogen sulfide gas, sulfurous acid gas, nitrous acid, chlorine gas, ammonia or bromine gas).

DIP ALUMINUM ELECTROLYTIC CAPACITORS RD SERIES

- 4) Aluminum Electrolytic Capacitors should not be stored under exposure to ozone ,ultraviolet rays or radiation.
- 5) After one year, a capacitor should be reconditioned by applying rated voltage in series with a 1000Ω current limiting resistor for a time period of 30 minutes .

7. DISPOSAL

Please take either of the following actions in case of disposal. Incineration (high temperature of more than 800°C) after crushing the capacitor's body; Consignment to specialists of industrial waste.

DISCLAIMER

NextGen Component, Inc. reserves the right to make changes to the product(s) and or information contained herein without notice. No liability is assumed as a result of their use or application. No rights under any patent accompany the sale of any such product(s) or information

11/25/2022

17