

THIS COPY IS PROVIDED ON A RESTRICTED BASIS AND IS NOT TO BE USED IN ANY WAY DETRIMENTAL TO THE INTERESTS OF PANDUIT CORP.

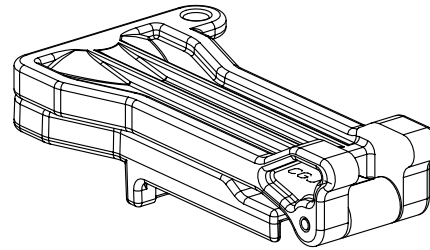
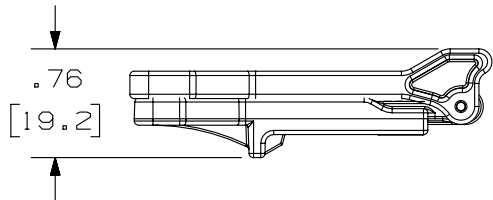
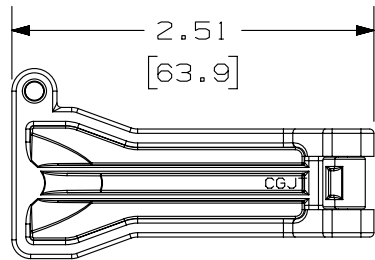
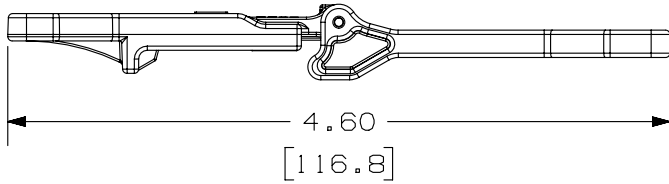
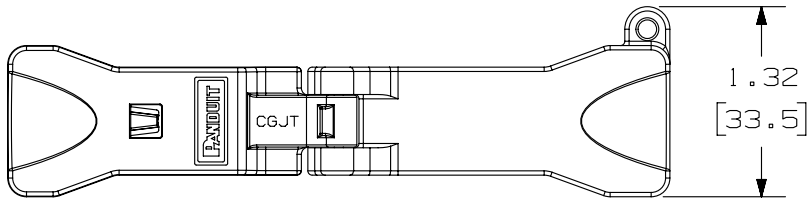

ACTUAL SIZE (FOLDED)

PANDUIT P/N	WEIGHT
CGJT	.28 LB/10 PCS (127.0 g/10 PCS)

- NOTES:
1. SEE CURRENT CATALOG FOR PACKAGE QUANTITY.
 2. SEE CATALOG FOR COMPLETE LIST OF PARTS APPLICABLE FOR USE WITH THIS PART.
 3. DIMENSIONS IN PARENTHESES ARE IN METRIC.
 4. MATERIAL: 20% GLASS FILLED NYLON.

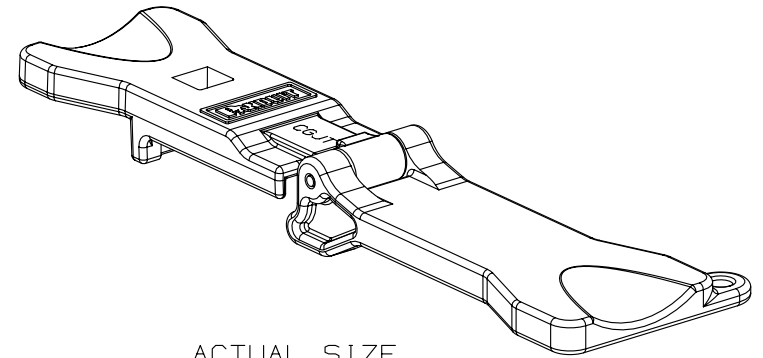

ACTUAL SIZE

PART NUMBER		CGJT	
TITLE			
JACK MODULE TERMINATION TOOL			
CUSTOMER DRAWING			
ITEM REVISION NAME		RA2436AD/00	
DATASET FILE NAME		RA2436AD_DC/00B	
UNLESS OTHERWISE SPECIFIED, DIMENSIONAL TOLERANCES ARE: IN [mm]			
.x ± .xxx ± .010 [.3]			
.xx ± .03 [.8]		MATERIAL:	
ANGLES ±		SEE NOTES	
DRAWN BY		DRAWING NUMBER:	
JSP		02436-05	
DATE		SCALE	
9-24-98		NONE	
CHK		SHT 1 OF 1	
FJD		A	
THIRD ANGLE PROJECTION			

REV	DATE	BY	CHK	APR	DESCRIPTION	ECN
3	4/22/14	JSP	REFR	EJH	REVISED AND REDRAWN, PREVIOUS REVISIONS HAVE BEEN OMITTED.	02426-05

D101000DA/14