



3300-3800 MHz Mono Block Ceramic Filter

ANATECH ELECTRONICS INC
RF & Microwave Filters & Products

Part Number: AM3550B989



Electrical specifications

Center Frequency: 3550 MHz
Bandwidth: 500 MHz
Input / Output Impedance: 50 Ohms
Passband: 3300-3800 MHz
Passband Insertion Loss: <1.3 dB
Passband Ripple: 0.9 dB
Passband Return Loss: 12 dB
Rejection: 40 dB@2300-2700 MHz
Power Handling: 3 Watts max

Mechanical

Mounting Method: SMT
Dimensions: 10.03 x 3.68 x 2.80 mm

Environmental

Operating Temperature: -40°C to +85°C
Storage Temperature: -30°C to +90°C

This product is RoHs compliant.

Outline Drawing:

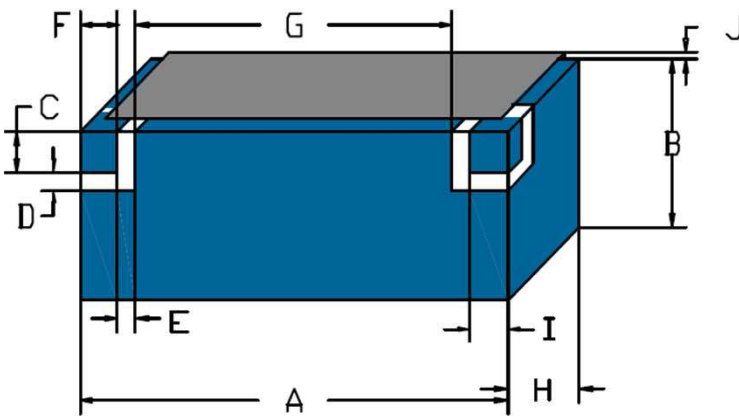

Dim	Nominal (mm)	Tolerance (mm) +/- or max
A	10.03	Max
B	2.80	Max
C	1.02	0.13
D	0.80	0.13
E	0.80	0.13
F	1.02	0.13
G	6.30	0.13
H	3.68	Max
J	0.76	0.13



3300-3800 MHz Mono Block Ceramic Filter

ANATECH ELECTRONICS INC
RF & Microwave Filters & Products

Part Number: AM3550B989



Electrical Response:

