

AC Semiconductor Contactor
pitch 22,5mm with Diagnostic
compact size and DIN rail mounting.

SILD865170

Output : 150-510VAC 32A(*)
Input : 3,5-32VDC - I<10mA
Diagnostic : 30VDC - 100mA

- ❑ **Ready to use Single-Phase Relay:** " Install it & Forget it!"
 Zero cross model : 150-510VAC
 50A back to back thyristors on output
 TMS² technology - I²t value > 1500A²s
 I²t values on request to 5 000A²s.
- ❑ **Model with diagnostic :** status of the SSR and the load .
 Normally closed status output .
 Without external power supply .
 Status visualization by yellow LED (*).
 Status output can be chained.
- ❑ **Very high immunity :** Voltage protection on output
 and input- 4kV according IEC61000-4-4 & 5
- ❑ **Large control range :** 3,5-32VDC with an input
 current < 10 mA on all the range.
 Green LED visualization on the input.
- ❑ **IP20 housing**
- ❑ **Low zero cross voltage (<15V)**
- ❑ **Mounting and dismounting on DIN rail without any
 tool or directly mountable on panel.**
- ❑ **Designed in conformity with EN60947-4-3
 (IEC947-4-3) and EN60950 -UL-cUL**

PATENTED !



28A 

(*) see conditions (thermal curve page 4)

Dimensions :

(*) : was Red on the first pieces.

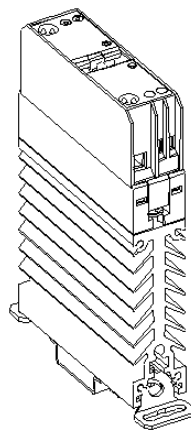
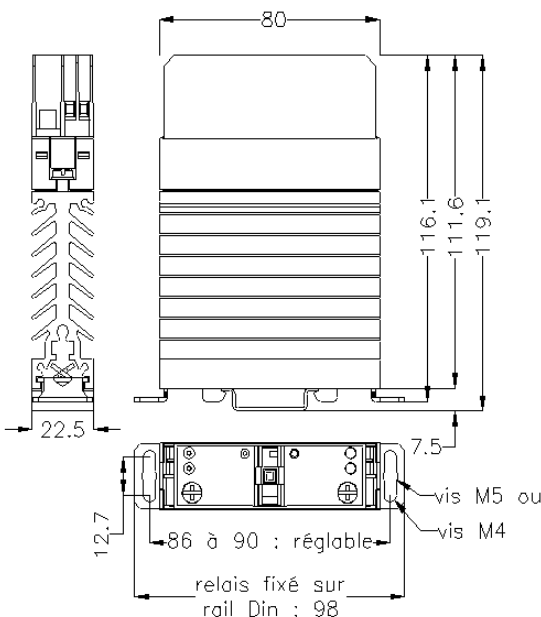

400VAC 50hz

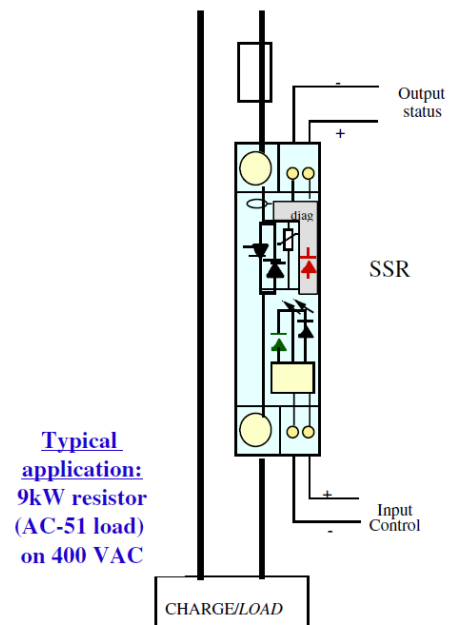

Typical application:
9kW resistor
(AC-51 load)
on 400 VAC

Proud to serve you

Control characteristics (at 25°C)

| Parameter | Symbol | DC | | | Unit |
|------------------------------|--------|-------|---------|-----|------|
| | | Min | Nom | Max | |
| Control voltage | Uc | 3,5 | 5-12-24 | 32 | V |
| Control current (@ Uc) | Ic | <10 | <10 | <10 | mA |
| Release voltage | Uc off | 2 | | | V |
| Input LED | | green | | | |
| Reverse voltage | Urv | | 32 | | V |
| Clamping voltage | Uclamp | | 42 | | V |
| Input immunity : EN61000-4-4 | | | 2kV | | |
| Input immunity : EN61000-4-5 | | | 2KV | | |

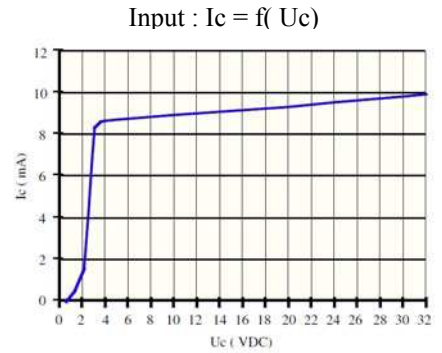

Output characteristics (at 25°C)

| Parameter | Conditions | Symbol | Typ. | Unit |
|--|-----------------------|------------------|-------------------------------|------------------|
| Load voltage | | Ue | 400 | V rms |
| Operating range | | Uemin-max | 150-510 | V rms |
| Peak voltage | | Up | 1200 | V |
| Clamping voltage | | Uclamp | 820 (@1mA) | V |
| Zero cross level | | Usync | 14 | V |
| Latching voltage | Ie nom | Ua | 14 | V |
| AC-51 nominal current : permanent | (see Fig. 2 page 4) | Ie AC-51 | 32 | A rms |
| AC-53 nominal current | | Ie AC-53 | 12 | A rms |
| Non repetitive overload current | tp=10ms (Fig. 3) | Iism | 550 | A |
| On state voltage drop (typical value) | @ 25°C | Vt | 0,9 | V |
| Dynamic resistance (typical value) | | rt | 8 | mΩ |
| Output Power dissipation (typical value) | | Pd | 0,81xIe+0,008xIe ² | W |
| Thermal resistance between junction to air | | Rthj/a | 3,3 (2,5) | K/W |
| Off state leakage current | @Ue, 50Hz | Ilk | <5 | mA |
| Minimum load current | | Iemin | 100 | mA |
| Turn on time | Uc nom DC ,f=50Hz | ton max | 10 | ms |
| Turn off time | Uc nom DC ,f=50Hz | toff max | 10 | ms |
| Operating frequency range | | f | 40-440 | Hz |
| Off state dv/dt | | dv/dt | 500 | V/μs |
| Maximum di/dt non repetitive | | di/dt | 50 | A/μs |
| Izt (<10ms) | | I ² t | 1500 | A ² s |
| Conducted immunity level | IEC 1000-4-4 (burst) | | 4kV criterion A | |
| Conducted immunity level | IEC 1000-4-5(schocks) | | 4kV criterion A | |
| Short circuit protection | FERRAZ | | gRC 25A/32A/50A/63A 14x51 | |

General characteristics (at 25°C)

| | | | |
|---|------------------|--------------------------|------|
| Input to output insulation | Ui | 4000 | VRMS |
| Output to status insulation | Ui | 2500 | VRMS |
| Output to case insulation | Ui | 4000 | VRMS |
| Insulation resistance | Ri | 100 (@500VDC) | MΩ |
| Rated impulse voltage | Uimp | 4000 | V |
| Protection level / CEI529 | - | IP20 | |
| Pollution degree | - | 2 | |
| Vibration resistance 10 -55 Hz according to CEI68 : | double amplitude | 1,5 | mm |
| Shocks resistance according to CEI68 (on DIN rail / with screws) | - | 30/50 | g |
| Ambient temperature (with no icing or condensation) | - | -40 /+80 | °C |
| Storage temperature (with no icing or condensation) | - | -40/+100 | °C |
| Ambient humidity | HR | 40 to 85 | % |
| Weight | | 260 | g |
| Conformity | | EN60947-4-3 (IEC947-4-3) | |
| Conformity | | UL/cUL pending | |

Proud to serve you

celduc®
r e l i a i s

Status output answer characteristics (at 25°C)

| Parameter | Conditions | Symbol | Min | Nom | Max | Unit |
|---|-----------------|--------|-----|-------|-----|------|
| Voltage range | Us | | 1 | 12-24 | 32 | V |
| Output current | Id | | 0 | 0,1 | 0,1 | A |
| On resistance | Rdson | | | | 2 | Ω |
| Open delay (faults) - fig. 1 | Uenom | to1 | | 70 | | ms |
| Total open delay (faults) - fig. 1 | Uenom, Uc=0V | to2 | | 120 | | ms |
| Closed mains delay | Uenom, Uc=Ucnom | tc1 | | | 20 | ms |
| Closed mains delay | Uenom, Uc=Ucnom | tc2 | | | 20 | ms |
| Maximum cable length for open load (maximum load due to capacitor) | | | | | 40 | m |

Diagnostic description

| Control | Control LED | Mains | Load | SSR | Status LED | Output status |
|---------|-------------|-------|------|---------------|------------|---------------|
| 0 | ○ | No | x | x | ○ | Open |
| 1 | ● | No | x | x | ○ | Open |
| 0 | ○ | Yes | OK | OK | ● | closed |
| 1 | ● | Yes | OK | OK | ● | closed |
| 0 | ○ | Yes | Open | OK | ○ | Open |
| 0 | ○ | Yes | OK | short-circuit | ○ | Open |
| 1 | ● | Yes | Open | OK | ○ | Open |
| 1 | ● | Yes | OK | short-circuit | ○ | Open |

Notices

- The red LED luminosity depends on :
 - Ue voltage.
 - Control : ON, OFF
 - Load type.
- The status outputs can be connected in serial for only one information.
- NPN/ PNP output is possible with status (insulation with the control) and no power supply for the relay.
- In case of using with a mains voltage lower than specifications, the SSR works correctly, but an alarm status can be given with control OFF.
 - In this case, the status works only with control ON with the diagnostic of open load or SSR short-circuit.

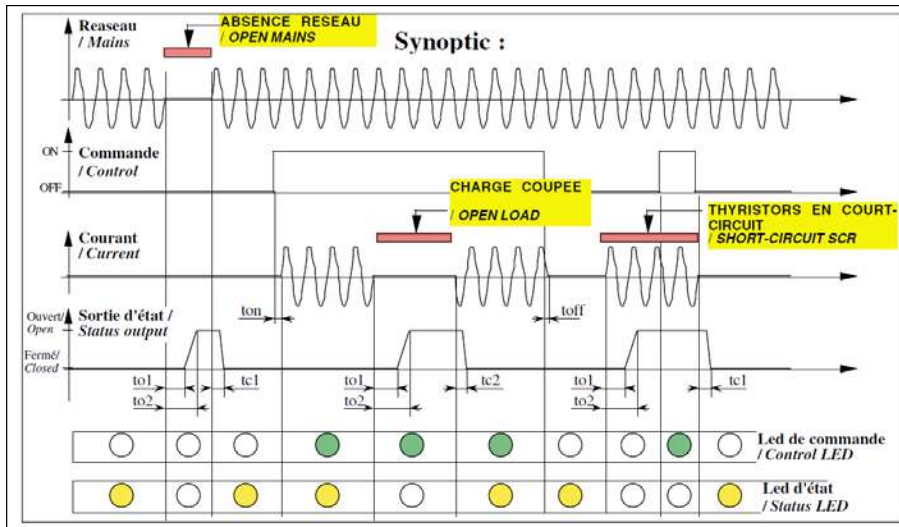

* Status (static output) is normally closed without failure on the relay and the load, and the yellow LED is switched ON :
That means there is
- voltage across the SSR without control.
- current inside the SSR with control .

* In case of failure on the load (opened) or on the SSR (short-circuited) :
- the status is opened .
- the yellow LED is switched OFF .

Important :

In case of long wiring cable between the SSR and the load (> 25 meters), it is possible than the diagnostic system can't detect an open load.

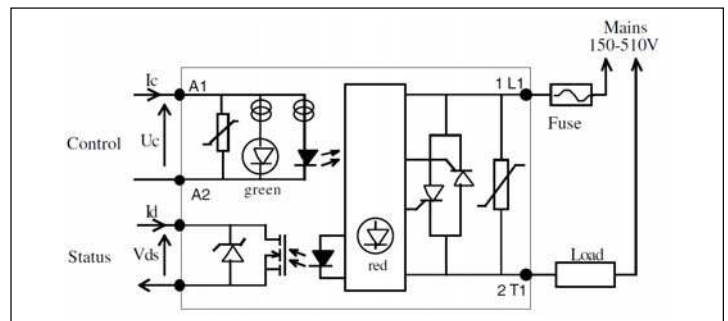

Proud to serve you

Thermal specifications.

- ♦ The curve "1" gives the limits of the product. The temperature reached are acceptable for the components. These values are in compliance with most of SSRs manufacturers. In a cabinet with a minimum of ventilation or a non permanent current, these values are correct.
- ♦ The curve "2" gives the limits of the product according to EN60947-4-3 with a maximum rise temperature of 50°C (@40°C) for a permanent working and in air calm (test during 8 hours).
- ♦ For a non permanent current, you can calculate the average power = $P_d \times \text{duty cycle}$ and check the rise temperature : $\Delta T_j = P_d \times R_{thj/a}$ (P_d and $R_{thj/a}$ are given page 2)). The junction temperature must not exceed 125°C at the maximum ambient temperature. The maximum current is limited to the size of the thyristors = 50A.
- ♦ The thermal constant (C_{th}) of the product is 7 minutes. That means the rise temperature is only 63% of the stabilized temperature after a running time of 7 minutes.

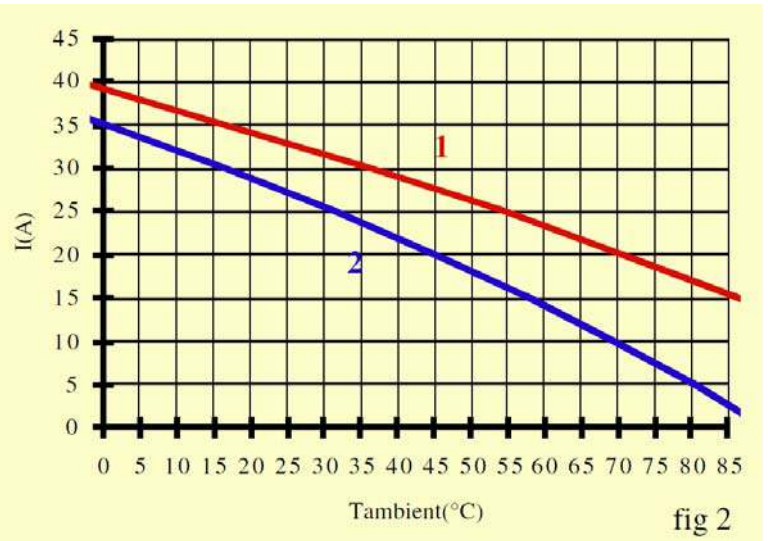

Overload current.

1 - No repetitive I_{tsm} is given without voltage reappplied . This curve is used for the determination of the protection.

2 - Repetitive I_{tsm} is given for inrush current with initial $T_j = 70^\circ C$. In normal working , this curve musn't be exceed. Be carefull, the repetition of the surge current decrease the lifetime SSR's .

fig 3

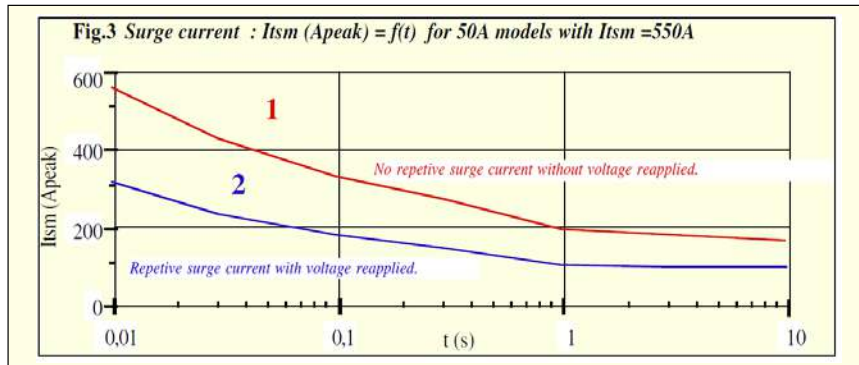

Mounting and dismounting on DIN rail without any tool.

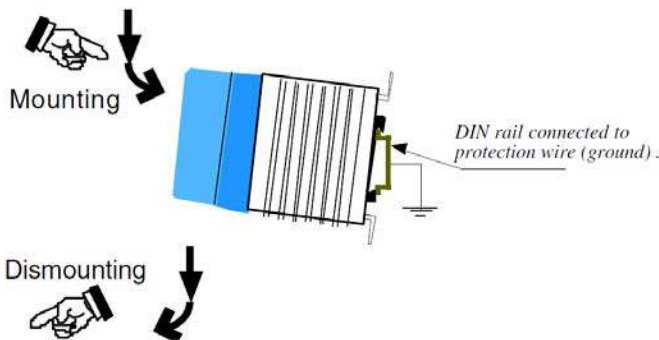

Panel Mounting

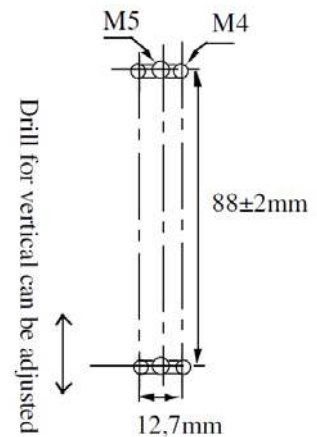

♦ **Warning !** semiconductor relays don't provide any galvanic insulation between the load and the mains. Always use in conjunction with an adapted circuit breaker with isolation feature or a similar device in order to ensure a reliable isolation in the event of wrong function and when the relay must be insulated from the mains (maintenance ; if not used for a long duration ...).

Proud to serve you

celduc®
r e l a i s

Connections.

♦ For the output terminals, the wire cross sections must be adapted to the load current and to the overcurrent protection device characteristics. The relay rated voltage must be adapted to the mains rated voltage.

♦ celpac use screw clamp connections.



| wires (mm ²) | torques | screwdriver |
|--|------------------------|-----------------------------|
| control 1 x(0,75-->2,5) L = 6mm | 0,4N.m (0,6N.m max) | 3,5x0,5mm |
| Power 1x(1,5-->16) 1 x(1,5-->10) L = 10mm | 1,2N.m (1,8N.m max) | Pozidriv2/ 0,8x5,5 (1x6) |

Mounting

♦ Only in vertical position:

The user should protect heat sensitive materials as well as persons against any contacts with the heatsink. For non vertical mounting , the load current must be 50% lower than the rated one . For a good cooling, the SSR needs an air convection. Less convection air produces an abnormal heating. Keep a distance between the upper SSR and the lower SSR. In case of no space between two SSR (zero space between two SSRs) , please reduce the load current. For further details refer to below :

♦ Derating current with no space between SSRs

AC-51 nominal currents are given with a space of 22,5mm between each SSR, for a permanent current during a minimum time of 8 hours in air calm according to IEC60947-4-3. In case of non permanent currents or in case of SSRs are mounted with no space, you must check the heatsink temperature never exceed 90°C. When the SSRs are mounted side to side (no space between each relay) a derating current of 25% must be take into account. A forced cooling (fan inside the cabinet) improves significantly the thermal performances.

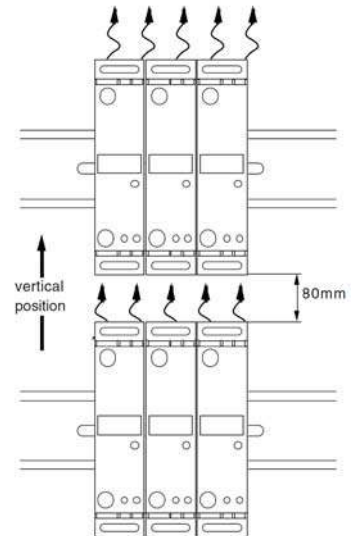

Typical application :

LOADS

SILD product is designed mainly for AC-51 resistive load. AC-53 motor current are also given . For other loads, check the inrush current at turn ON and possible overvoltages at turn OFF or consult us :

- * AC-55b : Incandescent lamps : Inrush current is generally 10 times In during few 10ms. So limit the nominal current at about 15A.
- * AC-55a : Electric discharge lamp : These loads often have overcurrent at turn ON and overvoltage at turn OFF, so we advise to use 400VAC SSR on 230VAC mains.
- * AC-56a : Transformers loads : Very high inrush current up to 100 times In . We advise to use random SSR.
- * AC-56b : Capacitors loads : Very high current at turn ON and overvoltage at turn OFF, please consult us with 1600V peak SSR with high inrush current.

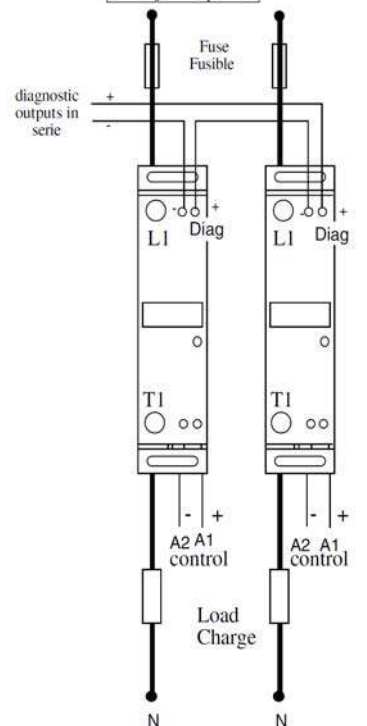

Protection :

To protect the SSR against a short-circuit of the load , use a fuse with a Ft value = 1/2 Ft value specified page 2. A test has been made with FERRAZ fuse (see page 2). It is possible to protect SSR by MCB (miniature circuit breaker). In this case, see application note (SSR protection) and use a SSR with high Ft value (5000A²s minimum).

EMC :

♦ Immunity :

We give in our data-sheets, the immunity level of our SSRs according to the main standards for this type of products : EN61000-4-4 & 5. You can see the high immunity level in comparison with the products on the market.

♦ Emission:

SSRs are complex devices which must be interconnected with other equipment (loads, cables,etc.) to form a system. Because the other equipment or the interconnections may not be under the control of celduc, it shall be the responsibility of the system integrator to ensure that systems containing SSRs comply with the requirements of any rules and regulations applicable at the system level.. Consult celduc laboratory which can make some tests in your application.

