



SPECIFICATION FOR DYNAMIC SPEAKER

TOTAL PAGE 09

www.be-star.com

RoHS

Customer	Baxter	Model Name	BMS28-12B-08H05CW152J LF
Customer P/N	720-0004-01-1	Product No.	131433
Date	09 Sep. 19	Issue No.	BS/TES01.856C1
Page	01 of 09	Issue Date	2019.09.09

Approval:

- 1.Characteristics
- 2.Bill of Material
- 3.Drawing
- 4.Reliability Test
- 5.Packing
- 6.History Change Record

Drawn by	Checked by	Approved by	Customer approved
任江凤	杨紫群	张勇磊	

BESTAR Holdings Co., Ltd.
No.199, West Huanghe Road, Changzhou, Jiangsu, P.R. China
Tel: +86 5196 789 6200
Fax: +86 5196 789 6220
E-Mail: Info@be-star.com
Web: www.be-star.com

BMS28-12B-08H05CW152J LF

1. Characteristic

1.1 Electrical and Mechanical Characteristics

No.	Item	Specification
1.	Impedance(at 1kHz)	$8\pm 15\% \Omega$
2.	Rated Input Power	0.8W
3.	Maximum Input Power	1.2W
4.	Resonance Frequency	$650\pm 20\% \text{Hz}$
5.	Frequency Response	F0 ~ 20KHz
6.	Output SPL (at 0.1W/0.1m)	$90\pm 3\text{dB}$ at 600 Hz
7.	Distortion (at 1kHz,0.1W)	$\leq 5\%$
8.	Buzzes & Rattles	Must be normal at sine wave 2.53V
9.	Magnet	NdFeB
10.	Operating Temperature	-20...+70 °C
1.	Storage Temperature	-40...+85 °C

1.2 Test Method

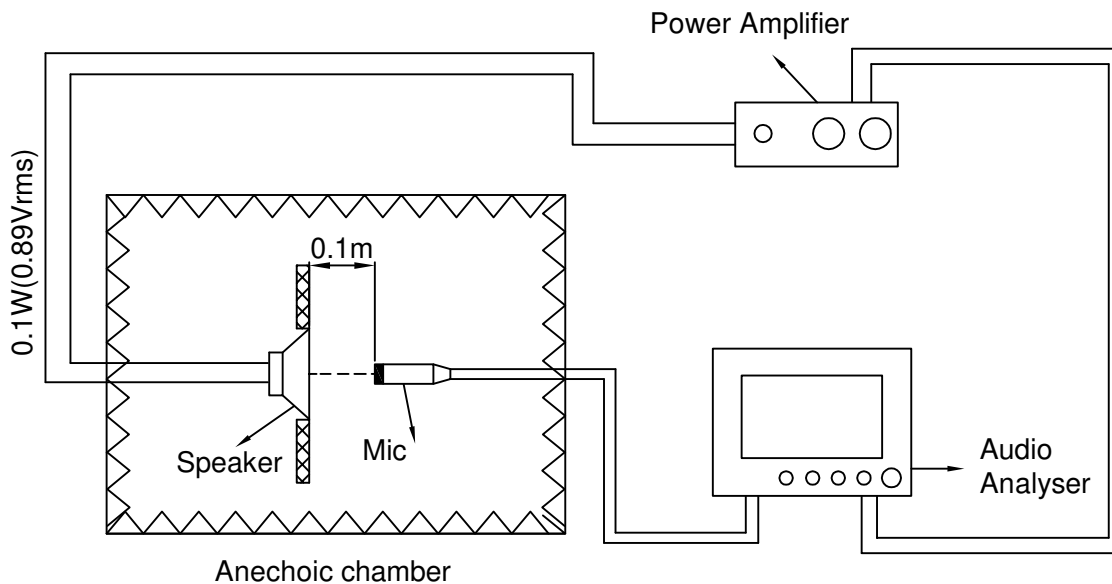

This print and information there in are proprietary to B. ESTAR Holdings Co., Ltd. and shall not be used in whole or in part without its written content.

				Date:	2019.09.09	BMS28-12B-08H05CW152J LF	
				Drawn by:	任江凤		
C1	2019.09.09	任江凤		Checked by:	杨紫群	Speaker	
Rev.	Date	Drawn	Note	Approved by:	张勇磊		
BESTAR Holdings Co., Ltd						DRG NO: BS/TES01.856C1	Page:02 of 09
http://www.be-star.com info@be-star.com							

BMS28-12B-08H05CW152J LF

1.3 Fundamental (0.1W/0.1m SOUNDCHECK testing)

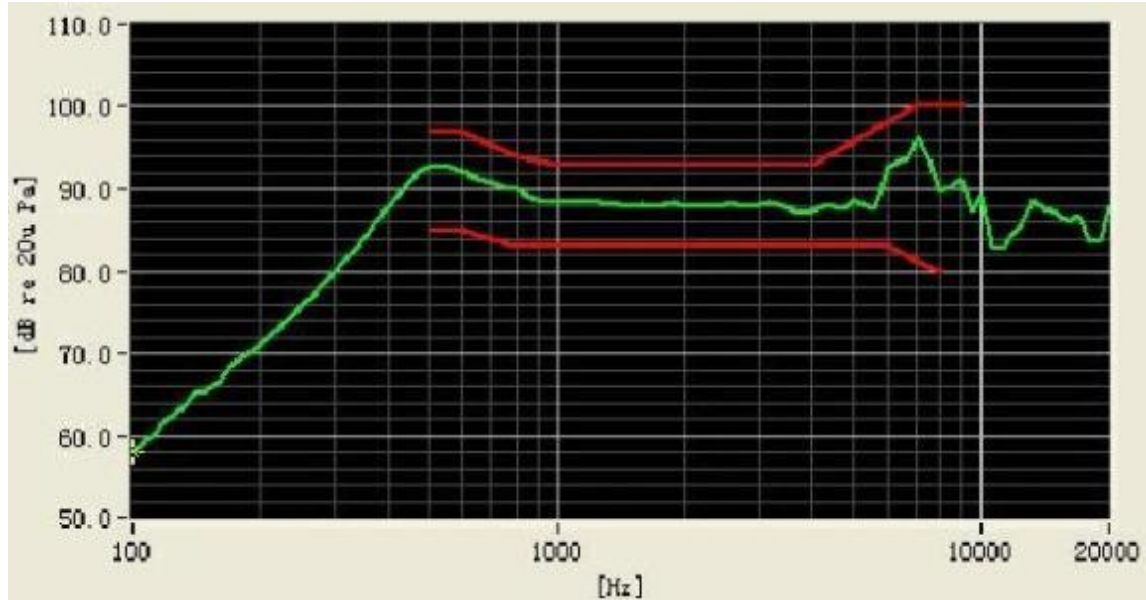

1.4 THD (0.1W/0.1m SOUNDCHECK testing)

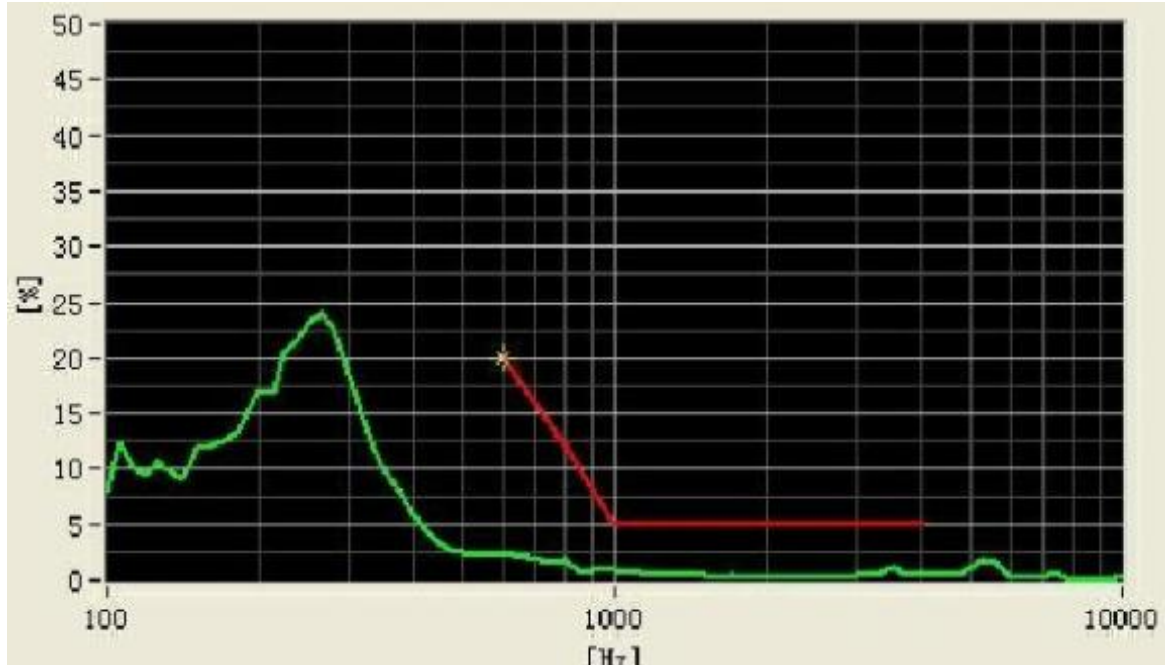

This print and information there in are proprietary to B-ESTAR Holdings Co., Ltd. and shall not be used in whole or in part without its written content

				Date:	2019.09.09	BMS28-12B-08H05CW152J LF	
				Drawn by:	任江凤		
C1	2019.09.09	任江凤		Checked by:	杨紫群	Speaker	
Rev.	Date	Drawn	Note	Approved by:	张勇磊		
BESTAR Holdings Co., Ltd						DRG NO: BS/TES01.856C1	Page:03 of 09
http://www.be-star.com info@be-star.com							

BMS28-12B-08H05CW152J LF

1.5 Impedance (0.1W/0.1m SOUNDCHECK testing)

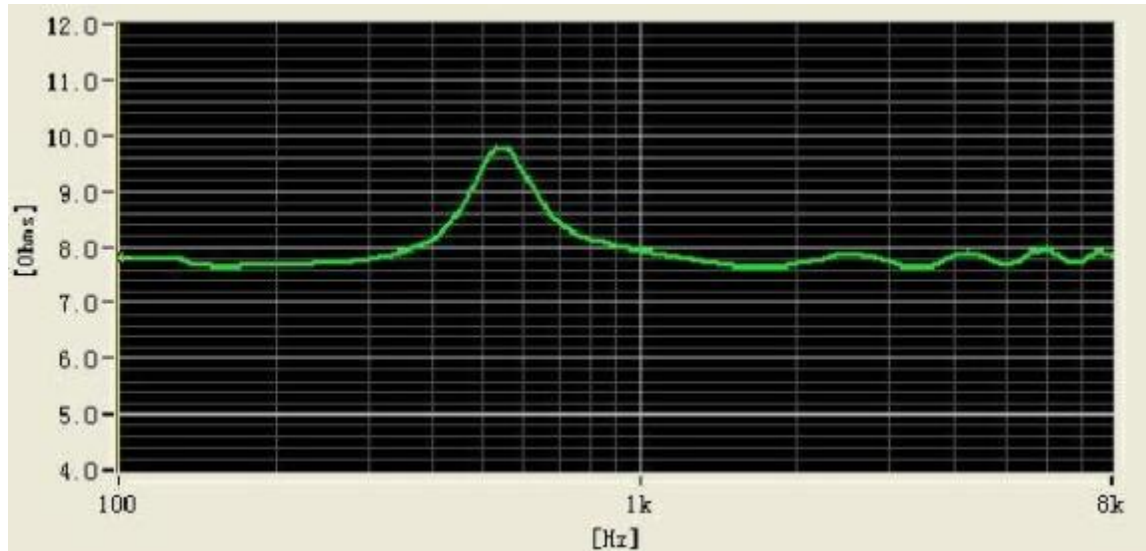

1.6 Rub&buzz (0.1W/0.1m SOUNDCHECK testing)

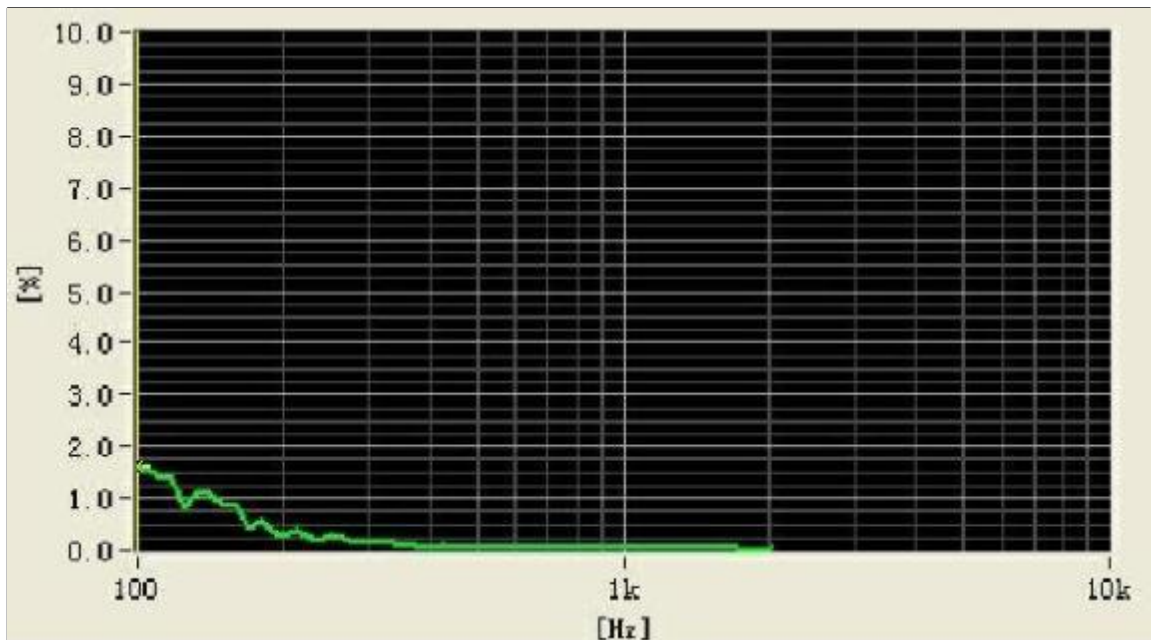

This print and information there in are proprietary to B-ESTAR Holdings Co., Ltd. and shall not be used in whole or in part without its written content

				Date:	2019.09.09	BMS28-12B-08H05CW152J LF	
				Drawn by:	任江凤		
C1	2019.09.09	任江凤		Checked by:	杨紫群	Speaker	
Rev.	Date	Drawn	Note	Approved by:	张勇磊		
BESTAR Holdings Co., Ltd						DRG NO: BS/TES01.856C1	Page:04 of 09
http://www.be-star.com info@be-star.com							

BMS28-12B-08H05CW152J LF

2. Drawing

2.1 Dimensions

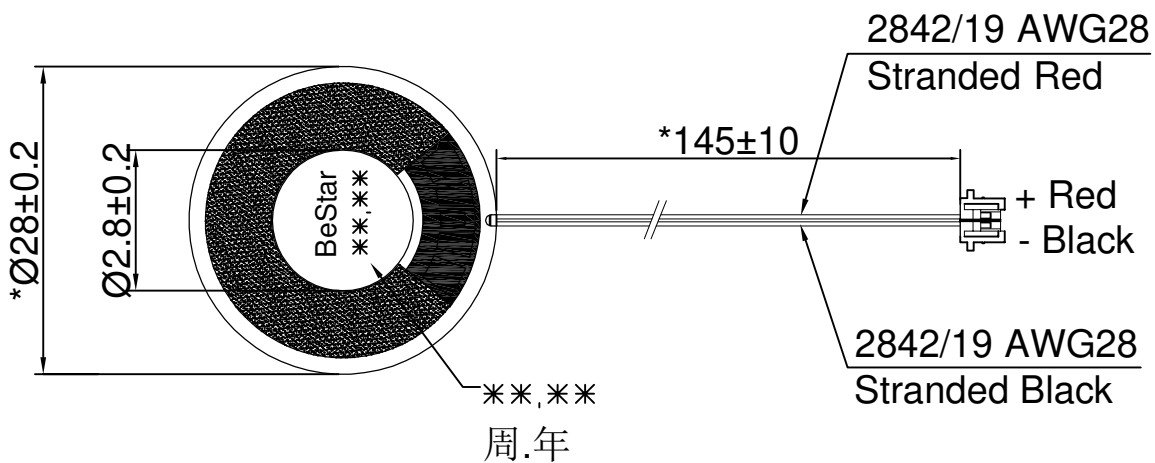
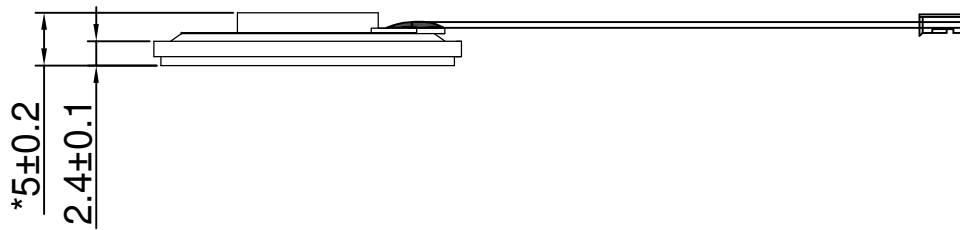
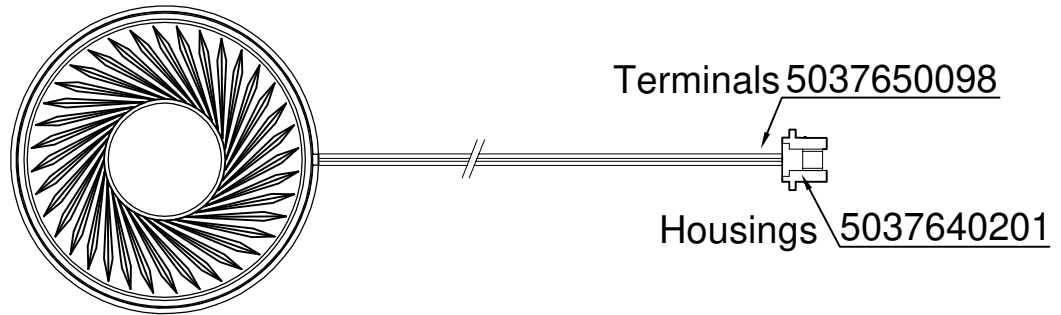

Unit:mm

This print and information there in are proprietary to B. ESTAR Holdings Co., Ltd. and shall not be used in whole or in part without its written content

				Date:	2019.09.09	BMS28-12B-08H05CW152J LF	
				Drawn by:	任江凤		
C1	2019.09.09	任江凤		Checked by:	杨紫群	Speaker	
Rev.	Date	Drawn	Note	Approved by:	张勇磊		
BESTAR Holdings Co., Ltd						DRG NO: BS/TES01.856C1	Page:05 of 09
http://www.be-star.com info@be-star.com							

BMS28-12B-08H05CW152J LF

2.2 Bill of Material

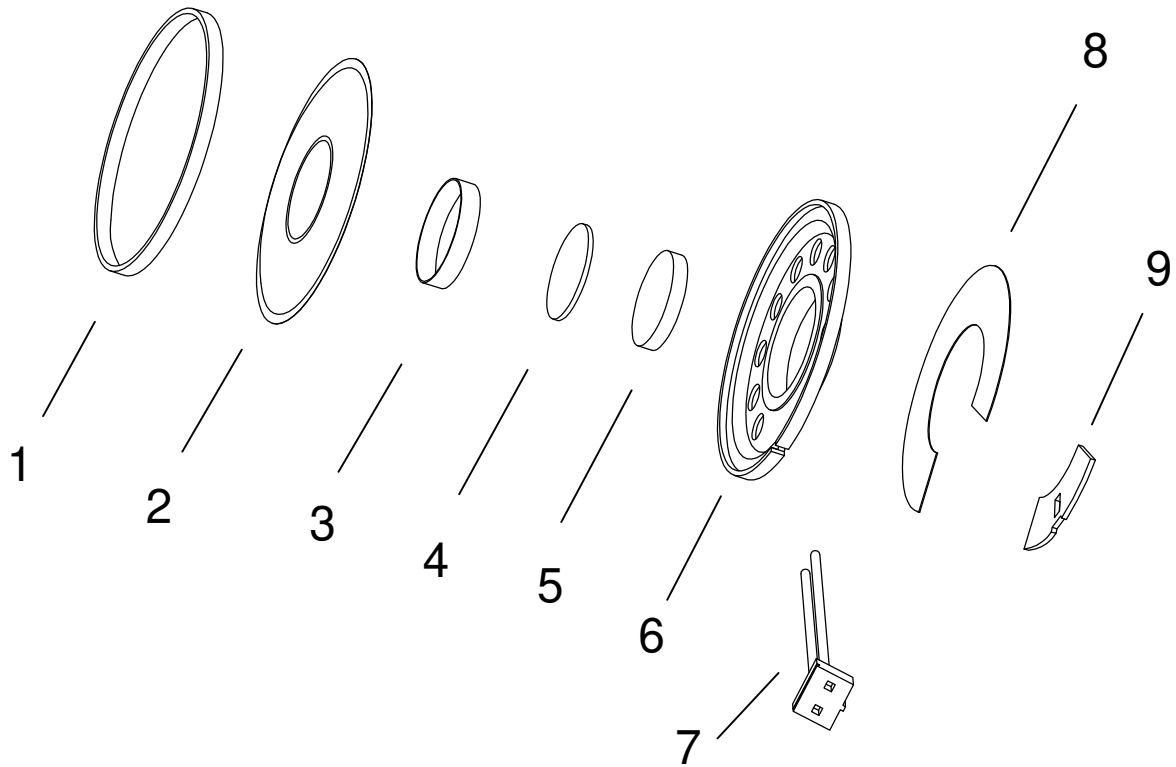

9	PCB	Epoxy and Cu(plating Sn)
8	Mesh	Cloth
7	Plug wire	Cu and PVC
6	Frame	SPCC
5	Magnet	NdFeB
4	Plate	SPCC
3	Voice coil	Cu
2	Diaphragm	PEN
1	Gasket	ABS
No	Parts Name	Material

Date:		2019.09.09		BMS28-12B-08H05CW152J LF	
Drawn by:		任江凤		Speaker	
Checked by:		杨紫群			
Approved by:		张勇磊			

Rev.	Date	Drawn	Note
C1	2019.09.09	任江凤	

This print and information there in are proprietary to B. ESTAR Holdings Co., Ltd. and shall not be used in whole or in part without its written content.

BMS28-12B-08H05CW152J LF

3. Reliability Test

- 3.1 Load Test
 - Power 0.8W White noise
 - Duration 96hrs
- 3.2 High Temperature Test
 - Temperature +85±3 °C
 - Duration 96hrs
- 3.3 Low Temperature Test
 - Temperature -40±3 °C
 - Duration 96hrs
- 3.4 Damp Heat
 - Temperature 40±3 °C
 - Relative Humidity 90%-95%RH
 - Duration 96hrs
- 3.5 Temperature Cycle Test
 - Cycle 5
 - 0.8W, F0~3500Hz, White noise

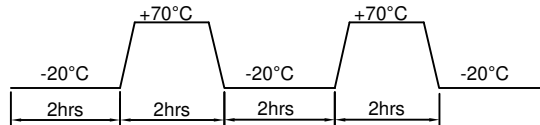

- 3.6 Drop Test
 - Height 75cm (in state of packing)
 - Times 10 (Drop onto hardwood board)
- 3.7 Vibration Test
 - 10 ~ 55 ~ 10Hz sin-wave sweep 15min. 5G (constant) X,Y,Z 3 directions 32 hours each, total 96 hours, 0.8W, F0~3500Hz, White noise
- 3.8 Lead wire pull strength
 - 3.0N for 30 sec. Horizontal, 2.0N 30 sec. vertical
- 3.9 PPAP documentation submit for medical reliability approval .

Notice

1. Immediately after reliability test, the samples shall be stored under typical ambient laboratory climate conditions unless otherwise noted for 4 hours prior to performing verification testing.
2. After reliability test, all samples must meet all specified requirements
3. Sensitivity differences at F0 ~ 5.0Khz must be within +/-3 of initial values.

				Date:	2019.09.09	BMS28-12B-08H05CW152J LF	
				Drawn by:	任江凤		
C1	2019.09.09	任江凤		Checked by:	杨紫群	Speaker	
Rev.	Date	Drawn	Note	Approved by:	张勇磊		
BESTAR Holdings Co., Ltd						DRG NO: BS/TES01.856C1	Page:07 of 09
http://www.be-star.com info@be-star.com							

This print and information there in are proprietary to B. ESTAR Holdings Co., Ltd. and shall not be used in whole or in part without its written content

BMS28-12B-08H05CW152J LF

4. Packing

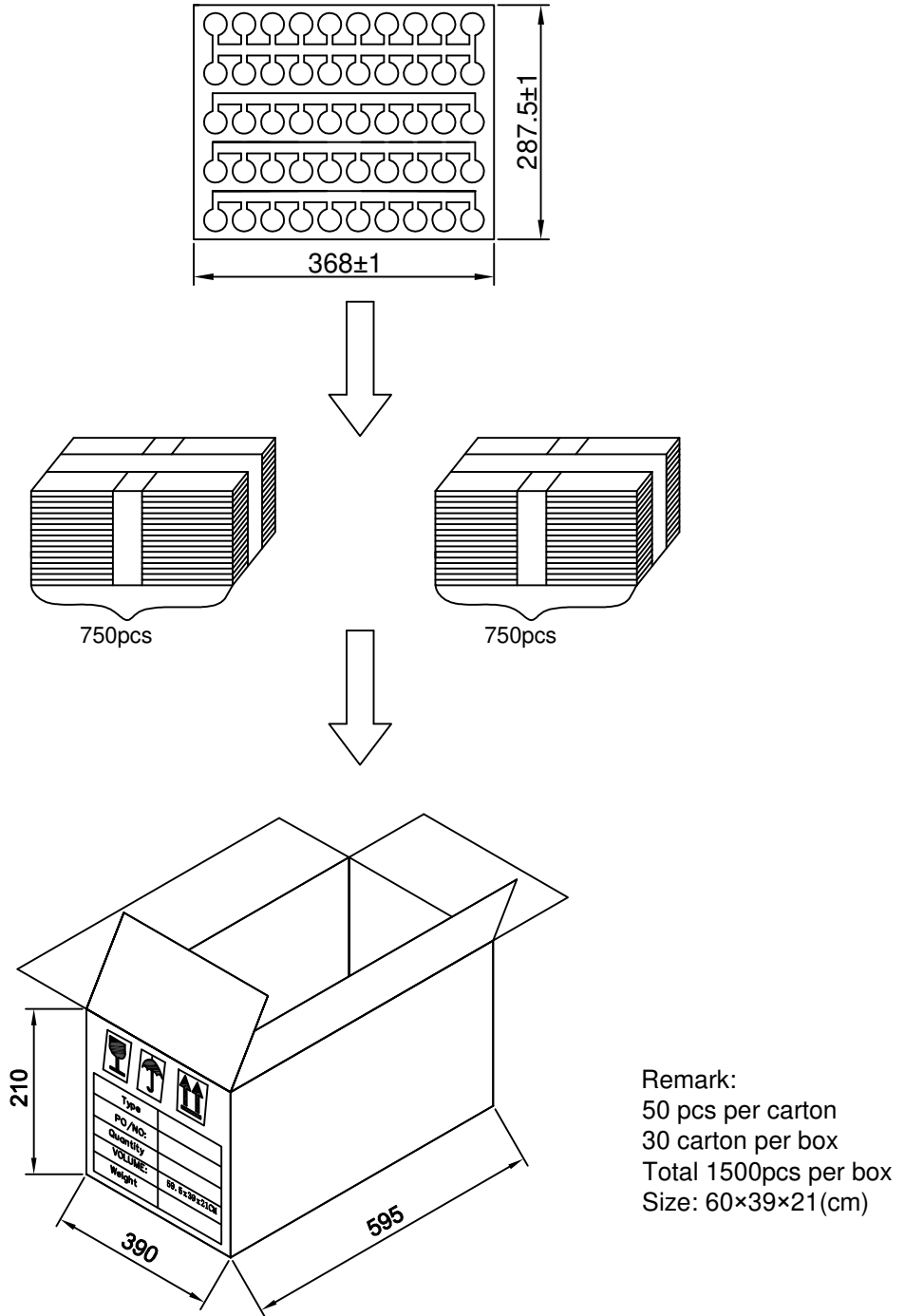

Remark:
 50 pcs per carton
 30 carton per box
 Total 1500pcs per box
 Size: 60×39×21(cm)

This print and information there in are proprietary to B. ESTAR Holdings Co., Ltd. and shall not be used in whole or in part without its written content

				Date:	2019.09.09	BMS28-12B-08H05CW152J LF	
				Drawn by:	任江凤		
C1	2019.09.09	任江凤		Checked by:	杨紫群	Speaker	
Rev.	Date	Drawn	Note	Approved by:	张勇磊		
BESTAR Holdings Co., Ltd						DRG NO: BS/TES01.856C1	Page:08 of 09

BMS28-12B-08H05CW152J LF

5. History change record

version No.	Change Items		Date	Drawn	Approved
	Before	After			
A			17/10/06	张翔捷	徐金国
B	Change the test conditions		18/02/22	张翔捷	徐金国
C	Change the wire . Increase customer information		19.07.25	任江凤	张勇磊
C1	Increase 3-3.9 PPAP documentation submit for medical reliability approval .		19.09.09	任江凤	张勇磊

This print and information there in are proprietary to B. ESTAR Holdings Co., Ltd. and shall not be used in whole or in part without its written content

			Date:	2019.09.09	BMS28-12B-08H05CW152J LF	
			Drawn by:	任江凤		
C1	2019.09.09	任江凤	Checked by:	杨紫群	Speaker	
Rev.	Date	Drawn	Note	Approved by:		张勇磊
BESTAR Holdings Co., Ltd					DRG NO: BS/TES01.856C1	Page:09 of 09
http://www.be-star.com info@be-star.com						