

REVISIONS			
REV.	DESCRIPTION	DATE	APPROVED
A	INITIAL RELEASE	03/03/17	D.N.

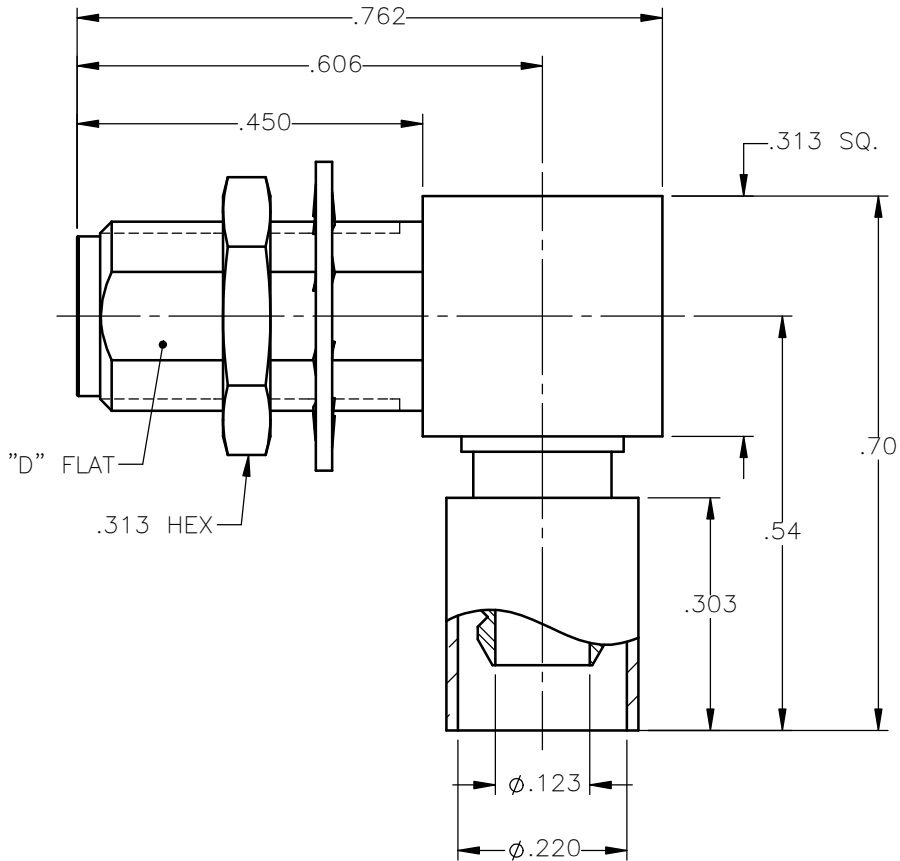

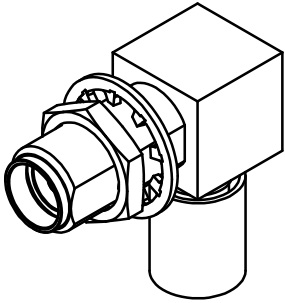

NOTES:

MATERIALS:

1. BODIES & NUT = STAINLESS STEEL PER ASTM A582, ALLOY 303, CONDITION "A".
2. INSULATORS = VIRGIN WHITE TEFLON PER ASTM D1710, GRADE 1, TYPE I, CLASS "B".
3. CONTACT = BERYLLIUM COPPER PER ASTM B196, ALLOY C17300, TEMPER TD04.
4. CAP = BRASS PER ASTM B16, ALLOY C36000, TEMPER H02.
5. LOCKWASHER = PHOSPHOR BRONZE PER ASTM B139, COPPER ALLOY C53400, TEMPER H04.
6. CRIMP SLEEVE = SEAMLESS LOWLEAD BRASS TUBE, ALLOY 330, SOFT ANNEAL TEMPER, .025/.060 GRAIN SIZE OR SEAMLESS COPPER TUBE PER ASTM B75, TYPE C12000, TEMPER: LIGHT ANNEAL 050 EXCEPT YIELD STRENGTH.
7. SHRINK SLEEVE = THERMOFIT SCL, BLACK (NOT SHOWN)

FINISHES:

1. BODIES & NUT = GOLD PLATE PER ASTM B488-11, TYPE II, 30µin MIN, GRADE C, OVER 50 TO 100µin STRESS FREE NICKEL PER AMS-QQ-N-290.
2. CONTACT = GOLD PLATE PER ASTM B488-11, TYPE II, 50µin MIN, GRADE C, OVER 100 TO 200µin STRESS FREE SULFAMATE NICKEL PER AMS-QQ-N-290.
3. ALL OTHER METAL PARTS = GOLD PLATE PER ASTM B488-11, TYPE II, 30µin MIN, GRADE C OVER 100 TO 200µin COPPER STRIKE PER AMS 2418.

UNLESS OTHERWISE SPECIFIED DIMENSIONS ARE IN INCHES TOLERANCES ON		DWN: DATE D.N. 03/03/17	 Property of Radiall This document cannot be reproduced or communicated to a third party without prior written permission of RADIALL.		
DECIMAL	ANGLE	CHKD: DATE J.S. 03/03/17			
	±2°	APVD: DATE J.M. 03/03/17			
REFERENCE:		MATERIALS & FINISHES: SEE NOTES	SMA RIGHT ANGLE JACK BULKHEAD MOUNT CRIMP TYPE FOR RG-55 & SIMILAR CABLES		
ORIGINATED: D.N. DATE: 03/03/17		SIZE A	FSCM NO. 19505	DWG NO. 9613-1523-001	REV A
		SCALE 4:1	THIRD ANGLE PROJECTION		SHEET 1 OF 1

9613-1523-001