

QT-Brightek Optocoupler Series

RANDOM-PHASE High Power TRIAC OPTOCOUPLER

Part No.: QTTX223 series

Product: QTTX223 series	Date: June 24, 2021	Page 1 of 14
	Version# 1.1	



Table of Contents:

Introduction3
Absolute Maximum Rating6
Electrical Characteristic ($T_A=25\text{ }^\circ\text{C}$).....7
Characteristic Curves.....8
Packing & Labeling12
Ordering Information13
Revision History14
Disclaimer14

Introduction

Feature:

- High Isolation voltage between input and output (Viso = 5000V rms)
- Peak Breakdown Voltage – 600V
- Peak Current Load – 0.3A, 0.6A, 0.9A and 1.2A

Certification & Compliance:

- Pb free and RoHS Compliant
- UL recognized (File #E338132)
- VDE recognized (File# 40049050)

Schematic:

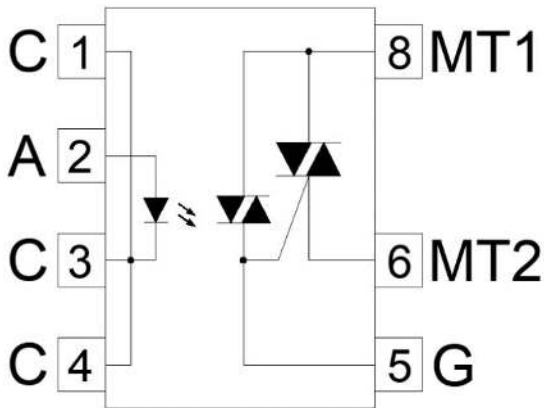

Dimension: (Dot location indicates pin 1) 7-Pin Dip (standard):

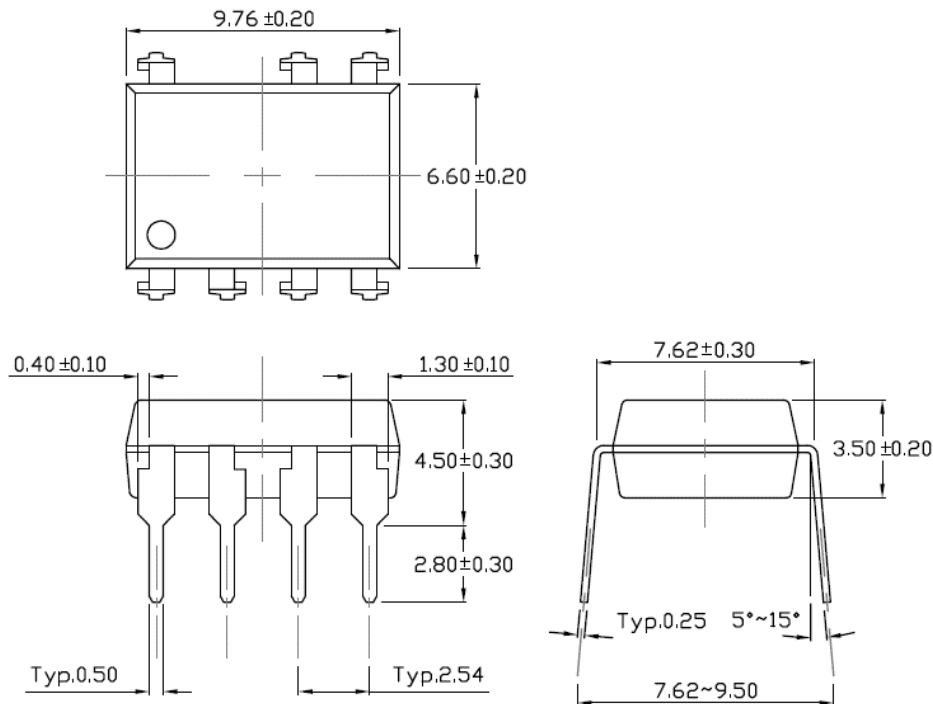

Gullwing (400mil) lead bend (Option M):

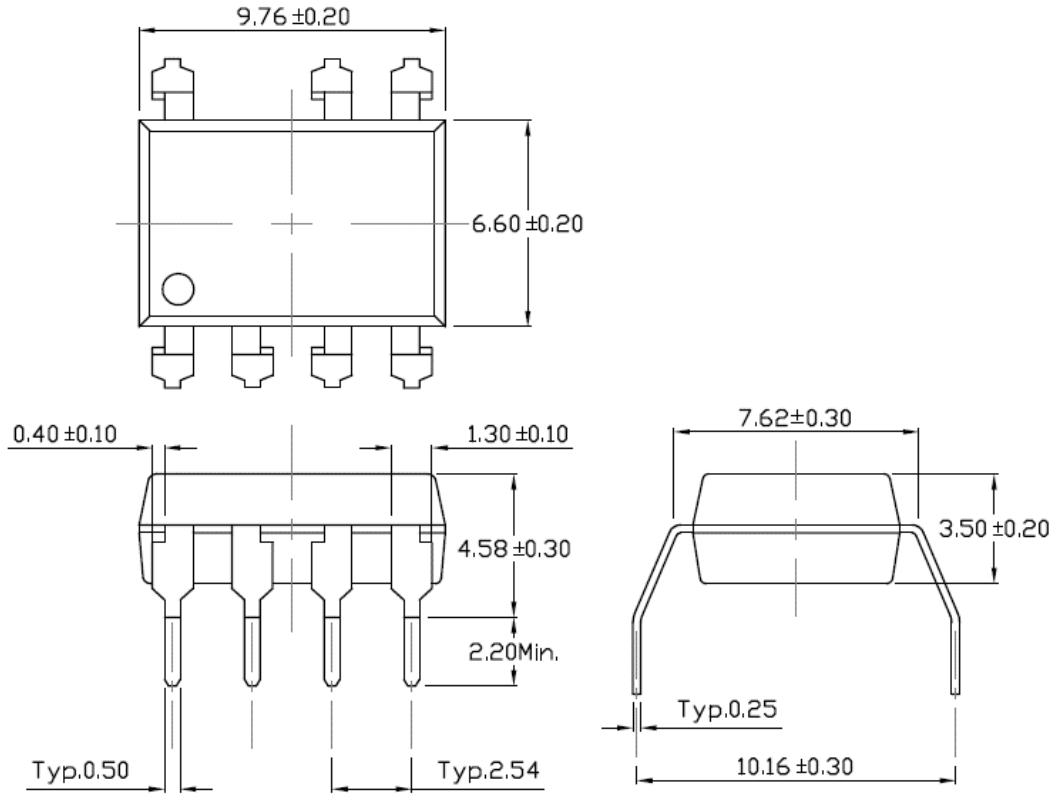

SMD lead bend (Option S):

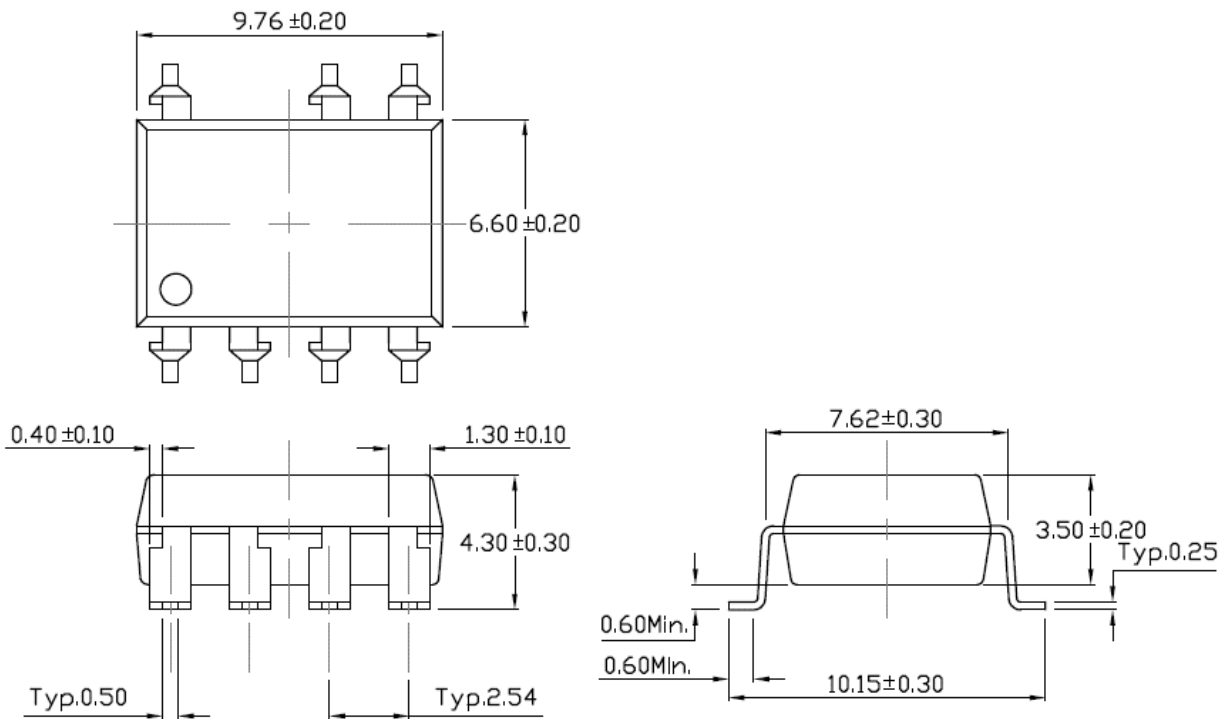

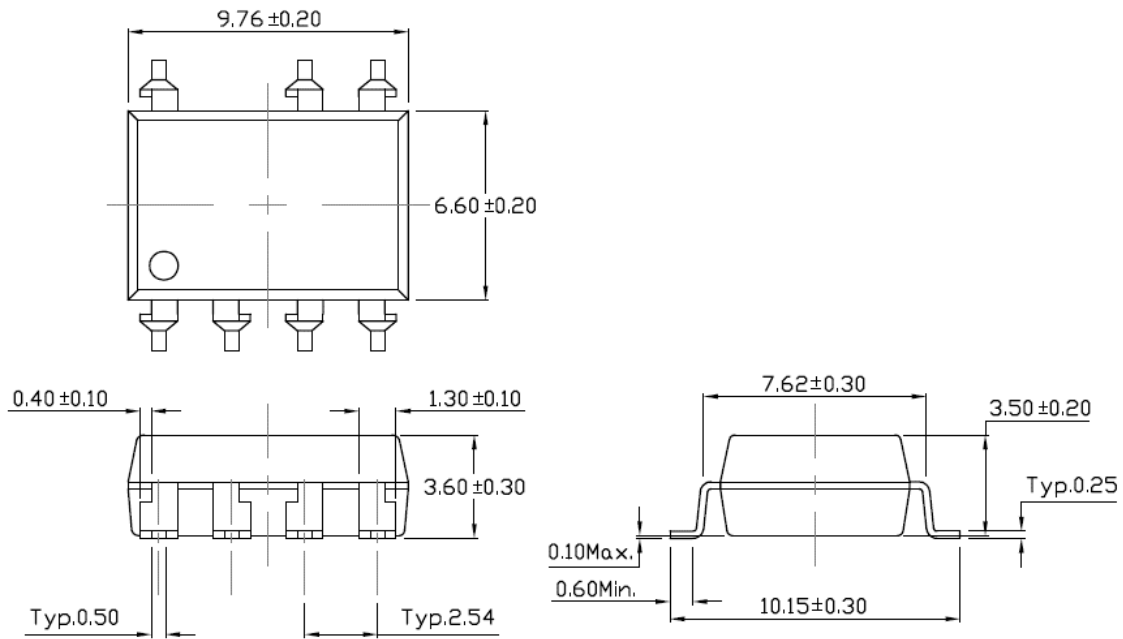
SMD (Low Profile) bend (Option SL):

All Dimensions are in mm

Absolute Maximum Rating

Symbol	Parameter	Rating	Units	
V_{ISO}	Isolation Voltage*	5000	V_{RMS}	
T_{STG}	Storage Temperature	-40 ~ +125	$^{\circ}C$	
T_{OPR}	Operating Temperature	-40 ~ +85	$^{\circ}C$	
T_{SOL}	Soldering Temperature	260 for 10 sec	$^{\circ}C$	
EMITTER				
I_F	Continuous Forward Current	50	mA	
I_{FP}	Peak Forward Current ($\leq 1\mu s, 300pps$)	1	A	
V_R	Reverse Voltage	6	V	
P_D	Power Dissipation	75	mW	
DETECTOR				
P_{OUT}	Power Dissipation	800	mW	
P_T	Total Power Dissipation	850	mW	
$I_{T(RMS)}$	Continuous Current Load	QTT0223	0.3	A
		QTT1223	0.6	
		QTT2223	0.9	
		QTT3223	1.2	
I_{TSM}	Peak Current Load	QTT0223	3	A
		QTT1223	6	
		QTT2223	9	
		QTT3223	12	
V_{DRM}	Repetitive peak OFF-state voltage	600	V	

Electrical Characteristic (T_A=25 °C)
Emitter

Symbol	Characteristic	Test Condition	Range			Unit
			Min	Typ	Max	
V _F	Forward Voltage	I _F = 10mA	-	-	1.3	V
I _R	Reverse Current	V _R = 6V	-	-	5	μA
C _{IN}	Input Capacitance	f = 1kHz	-	45	-	pF

Detector

Symbol	Characteristic	Test Condition	Range			Unit
			Min	Typ	Max	
I _{DRM}	Peak Blocking Current	V _{DRM} = Rated V _{DRM} , I _F = 0mA	-	-	100	μA
V _{TM}	Peak on-state voltage	I _{TM} = 100mA peak, I _F = Rated I _{FT}	-	-	2.5	V
dv/dt	Critical Rate of Rise off-state voltage	V _{PEAK} = Rated V _{DRM}	200	-	-	V/μs

Transfer Characteristic

Symbol	Characteristic	Test Condition	Range			Unit
			Min	Typ	Max	
I _{FT}	LED Trigger Current	Main terminal voltage = 3V	-	-	10	mA
I _H	Holding Current		-	-	25	mA
R _{IO}	Isolation Resistance	V _{IO} = 500V _{DC}	1x10 ¹¹	-	-	Ω
C _{IO}	Isolation Capacitance	F = 1MHz	-	0.25	-	pF

Characteristic Curves

QTTX213

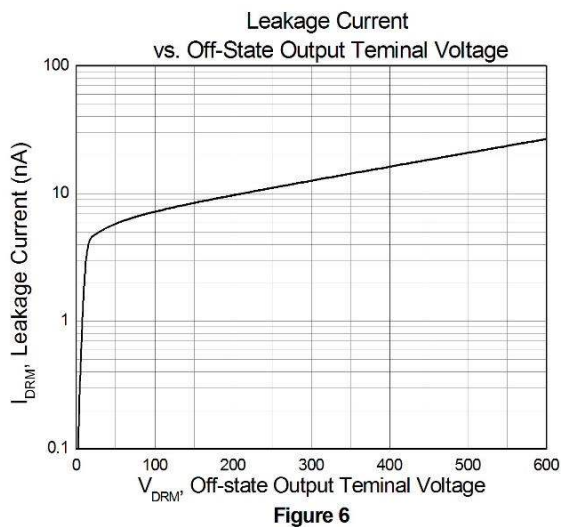
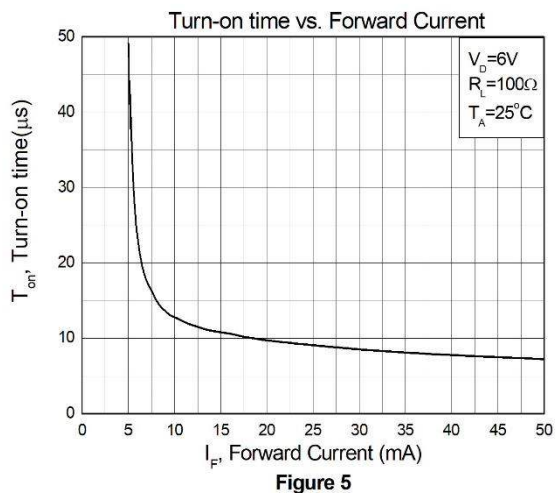
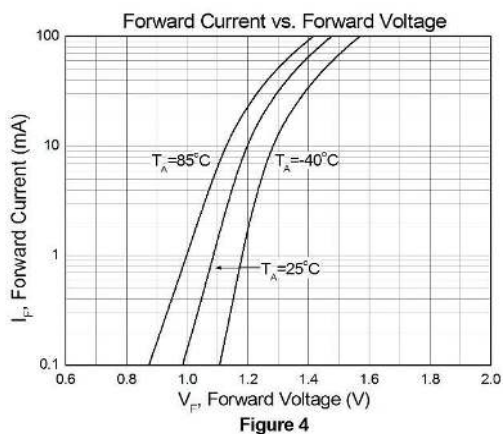
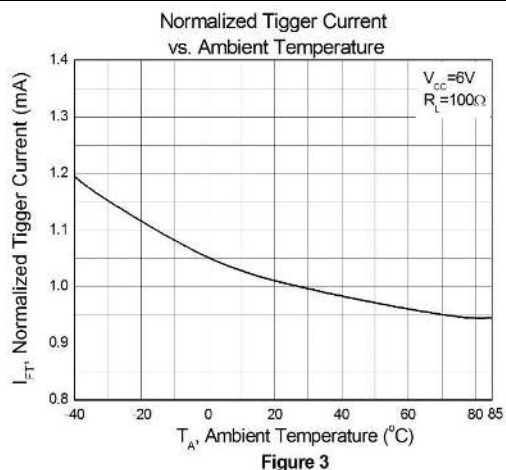
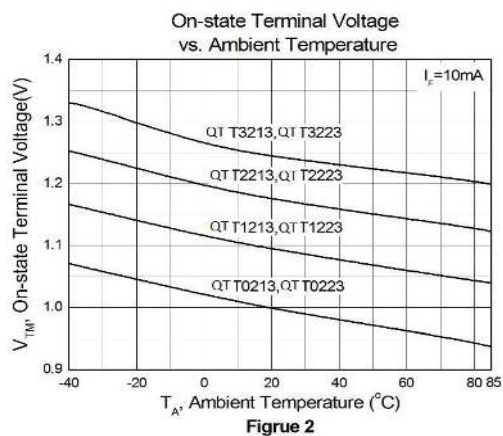
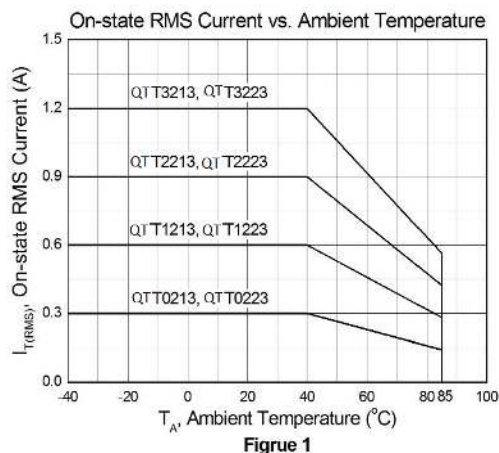

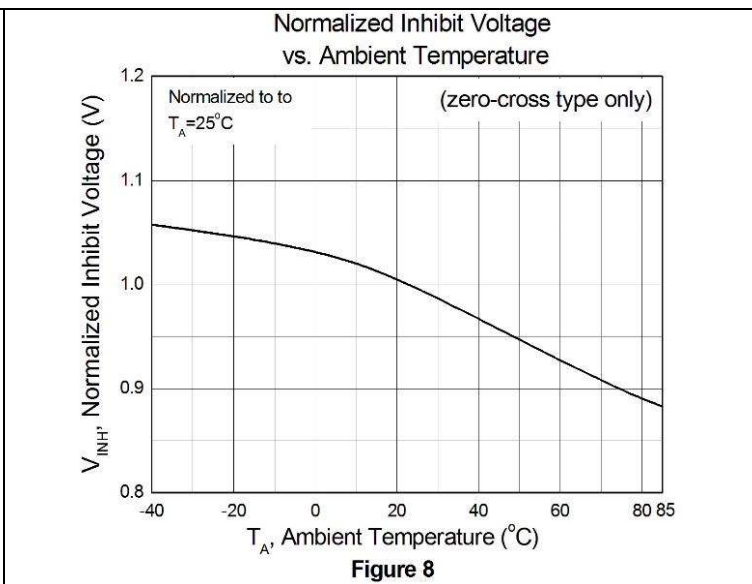
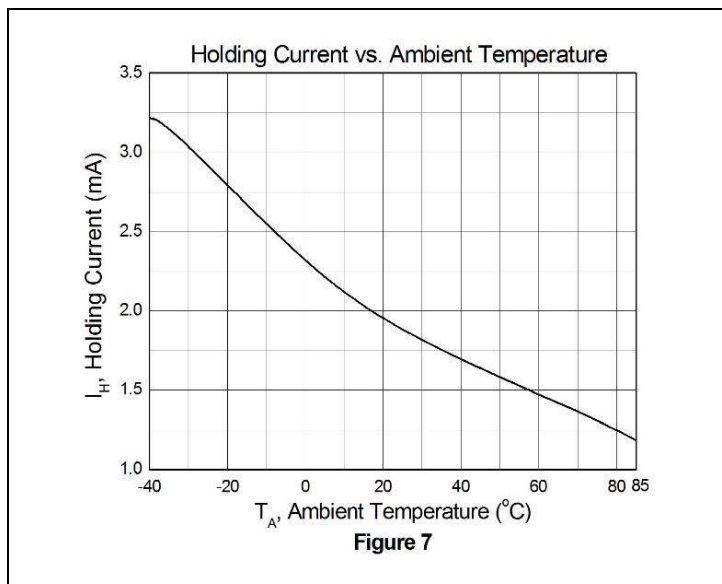

Solder Profile & Footprint

Wave soldering

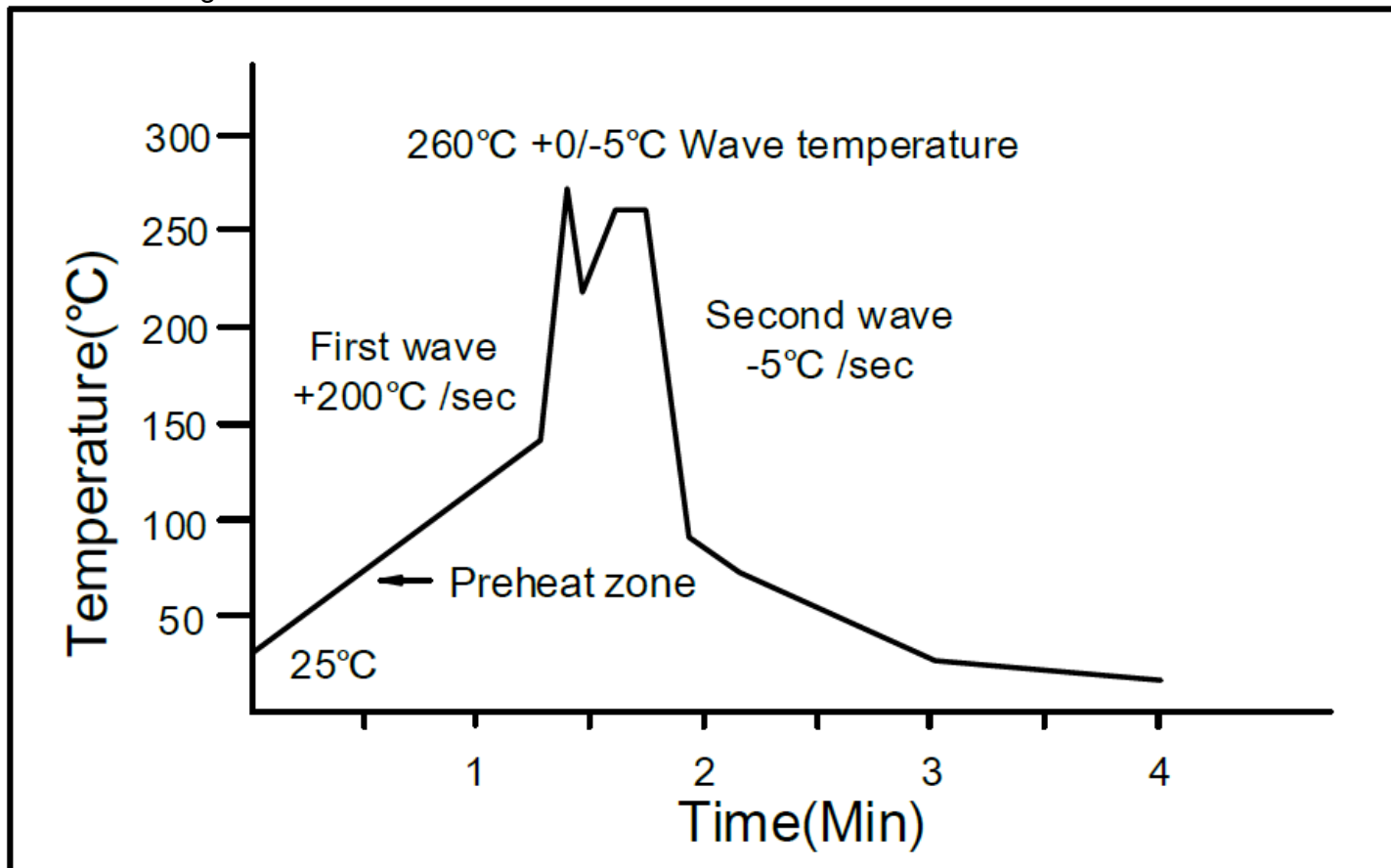

Temperature: 260 +0/-5 °C

Time: 10 Sec

Preheat temperature: 25 to 140 °C

Preheat time: 30 to 80 sec.

Reflow soldering

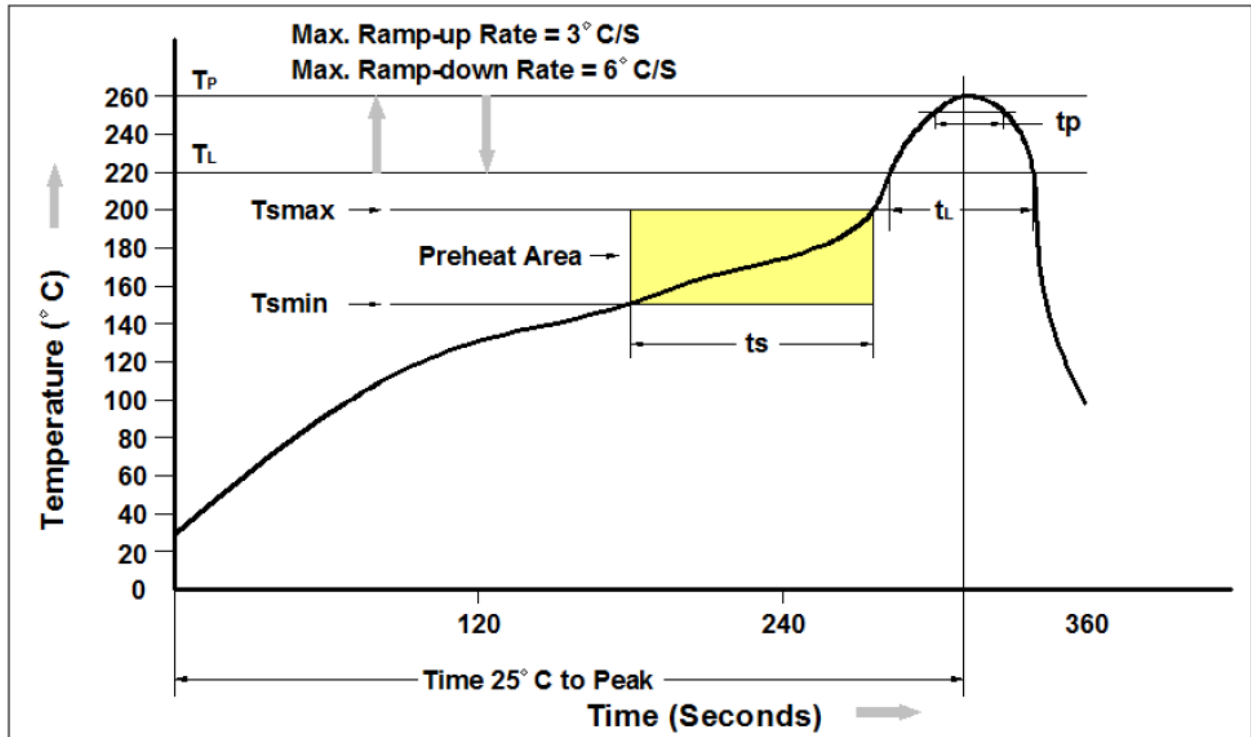

Profile Feature	Pb-Free Assembly Profile
Temperature Min. (T _{smin})	150 °C
Temperature Max. (T _{smax})	200 °C
Time (t _s) from (T _{smin} to T _{smax})	60-120 seconds
Ramp-up Rate (t _L to t _P)	3°C/second max.
Liquidous Temperature (T _L)	217 °C
Time (t _L) Maintained Above (T _L)	60 – 150 seconds
Peak Body Package Temperature	260 °C +0 °C / -5 °C
Time (t _P) within 5 °C of 260 °C	30 seconds
Ramp-down Rate (T _P to T _L)	6°C/second max
Time 25 °C to Peak Temperature	8 minutes max.

Packing & Labeling

Tape Dimension:
Option ST1 & SLT1

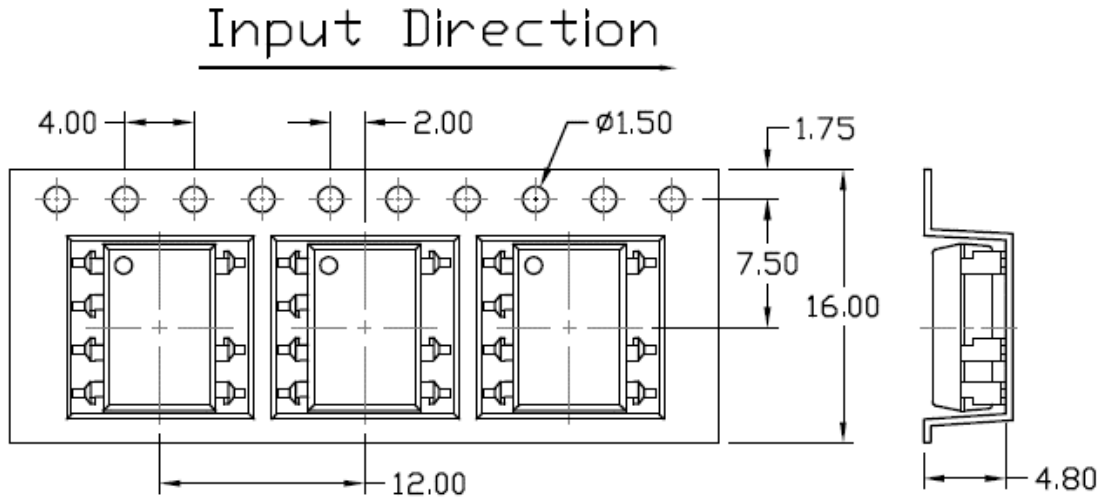

Option ST2 & SLT2

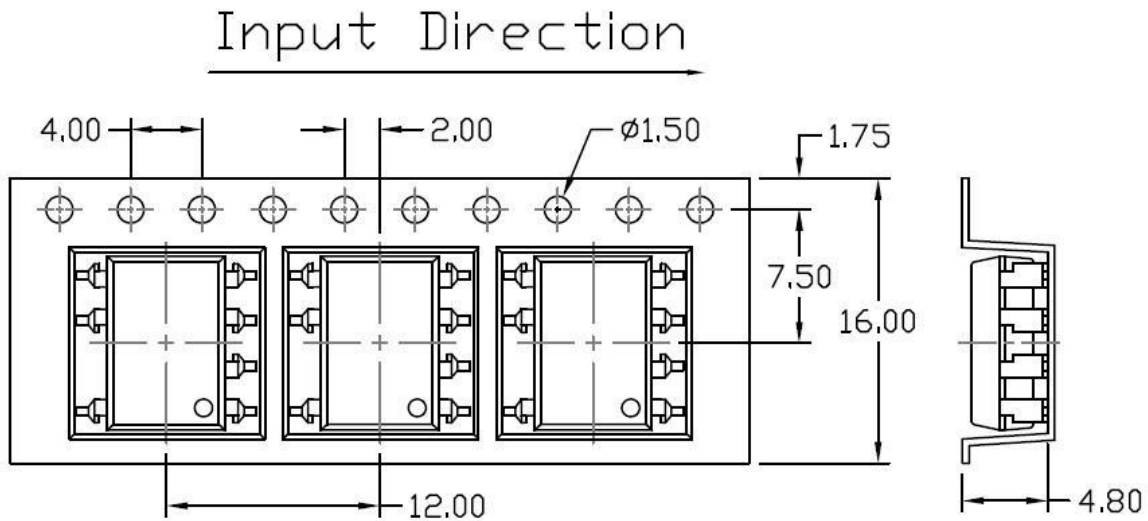

Unit: mm

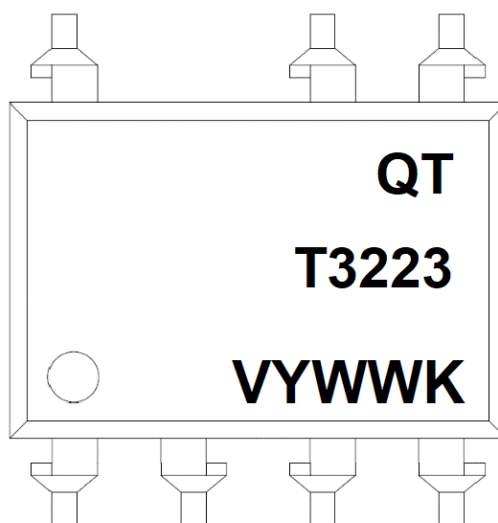
Device Marking:

QT = QT-Brightek Corporation
 T3223 = part number
 Y = Year
 WW = Week
 V = VDE Option
 K= Manufacturing code

Ordering Information

QTTX223VYZ

QT = QT-Brightek

TX223 = Part number (X=0, 1, 2, or 3)

V = VDE option (V or None)

Y = Lead form option (S, SL, M or none)

Z = Tape and reel option (T1 or T2 or none)

Option	Description	Quantity
None	Standard 7-Pin DIP	40 Units/Tube
M	Gullwing	40 Units/Tube
ST1	Surface Mount Lead Forming – with Option 1 Taping	1000 pcs/ reel
ST2	Surface Mount Lead Forming – with Option 2 Taping	1000 pcs/ reel
SLT1	SMD (Low Profile) Lead Forming – with Option 1 Taping	1000 pcs/ reel
SLT2	SMD (Low Profile) Lead Forming – with Option 2 Taping	1000 pcs/ reel



Revision History

Description:	Revision #	Revision Date
Initial of QTTX223 series	1.0	02/02/2018
Update schematic	1.1	06/24/2021

Disclaimer

QT-BRIGHTTEK reserves the right to make changes without further notice to any products herein to improve reliability, function or design. QT-BRIGHTTEK does not assume any liability arising out of the application or use of any product or circuit described herein; neither does it convey any license under its patent rights, nor the rights of others.

Life Support Policy

QT-BRIGHTTEK's products are not authorized for use as critical components in life support devices or systems without the express written approval of QT-BRIGHTTEK. As used herein:

1. Life support devices or systems are devices or systems which, (a) are intended for surgical implant into the body, or (b) support or sustain life, and (c) whose failure to perform when properly used in accordance with instructions for use provided in the labeling, can be reasonably expected to result in a significant injury of the user.
2. A critical component in any component of a life support device or system whose failure to perform can be reasonably expected to cause the failure of the life support device or system, or to affect its safety or effectiveness.