



QorIQ T4 Family

QorIQ T4240 Development System

Flexible development system for QorIQ T4 family of processors

Overview

The QorIQ T4240 development system (T4240QDS) is a flexible system that supports the twenty four virtual core T4240 processor but can also be configured to emulate the the 16 virtual threaded T4160 or eight virtual threaded T4080. With frequencies scaling to 1.8 GHz and rich input/output (I/O) mix, the T4240QDS is intended for development of enterprise and data center networking, telecom and industrial applications, where its high-performance, high-efficiency cores and integration make it very well suited as a combined control and data plane processor.

The T4240QDS can help shorten time to market. The board is built to allow the exercising of most capabilities of the device and can serve as a reference for system-level hardware development by providing a comparison tool for customer-specific board implementations. It can also be used for customer software development and performance evaluation.

Hardware

The T4240QDS main board is mounted in a 4U rack-mounted chassis and the main PCB is a custom form factor. An additional layer of flexibility for system clocking, power

distribution and I/O multiplexing is built into the T4240QDS. Although the main board includes features that will meet many customer use cases, eight expansion slots are provided for adding standard PCIe cards or Freescale specialized SerDes riser cards (SGMII or XAUI networking).

Linux® SDK

The T4240QDS is shipped with a prebuilt U-boot/Linux image programmed in flash memory to get developers up quickly to a Linux prompt. The system includes a Linux board support package (BSP) that provides a comprehensive starting point for Linux development efforts. This BSP is tested for the T4240, T4160, and T4080 processors and the T4240QDS development system, ensuring an operational tool chain, kernel and specific peripherals that are ready to use together. The T4240QDS Linux BSP includes U-boot boot loader, Linux kernel, device drivers, Yocto package manager, applications, services, libraries and GNU tools such as compilers and linkers.

Supported Features of the Linux SDK

- U-boot: Boot from NOR or NAND flash, DDR, DUART, I²C, networking, USB or PCIe
- Linux: Data Path Acceleration Architecture (DPAA) networking on 1G and 10G interfaces, PCIe, SATA, SDHC, USB, SEC, DCE, PME, SRIO
- User space DPAA (USDPA): QMan, BMan, RMan, SRIO, PME

QorIQ T4240 Development System Block Diagram

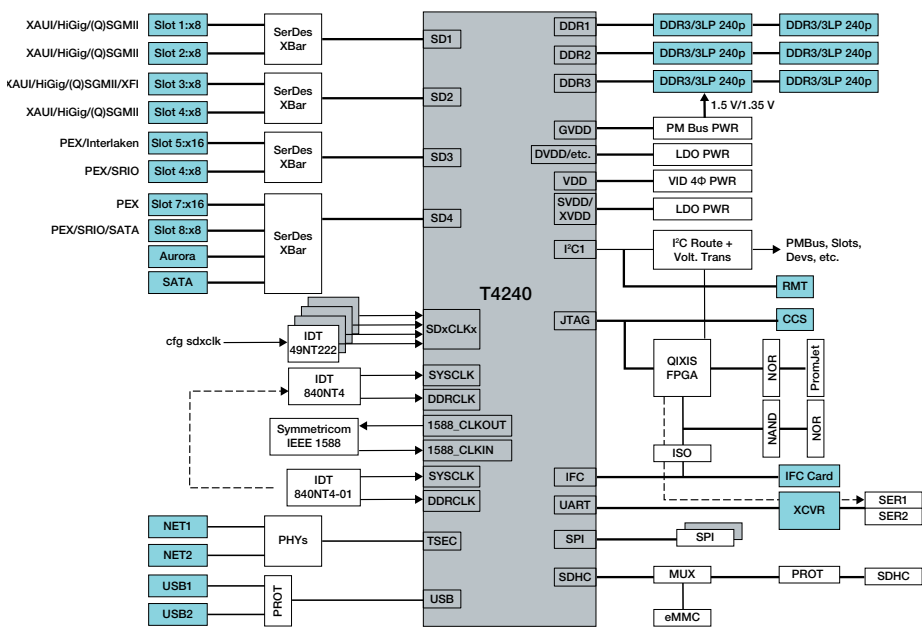

- FMan storage profiles
- QMan egress traffic shaping
- Hypervisor: KVM, Freescale embedded hypervisor, Linux containers
- Demonstration applications: Reflector, IPFwd, IPsec, SimpleCrypto, PME

QorIQ Configuration Suite

Freescale offers the QorIQ configuration suite to simplify the configuration of the flexible and powerful T4240 processor independent of the written reference manual. This suite of tools is implemented as a set of components, each of which knows the details of the silicon control registers, configuration specifics, muxing rules and the necessary value ranges for all the configuration properties. A simple wizard is used to select basic configuration values and to define settings, which in turn will generate source files for use in board initialization code for the T4240. The QCS is delivered as a plugin to a standard Eclipse environment, such as the Freescale CodeWarrior development studio.

Components of the QorIQ Configuration Suite

- Pre-boot loader configuration tool
- BOOTROM configuration tool
- DDR configuration tool
- DPAA component configuration
- Device tree editor

T4240QDS Board Features

Processor

- QorIQ T4240 processor, up to 1.67 GHz (currently) or 1.8 GHz (future) core with up to 1,866 MT/s DDR3 data rate
- Multiple SysCik inputs for generating various device frequencies

Memory

- Six sockets for DDR3 240-pin DIMM modules supporting with ECC (72-bit bus)
- Triple unbuffered DDR3 240-pin DIMM modules with ECC (72-bit bus), 24 GB memory shipped with the system
- 128 MB NOR flash, 16-bit
- 512 MB NAND flash, 8-bit (async)
- SPI serial 64 MB flash
- I²C serial 256 KB EEPROM
- eMMC 4 GB flash
- SD connector to interface with an SD memory card (no card shipped with system)

PCI Express® Expansion

- Up to four x4 PCI Express slots

SATA

- Two vertical SATA connectors

USB 2.0

- Two high-speed USB controllers

DUART

- Two DB9 connectors

Ethernet

- Supports two 10/100/1000 ports through RGMII to RJ45
- Up to four 10 GbE through XAUI connectors (requires riser cards)
- Up to 16 1 GbE through SGMII connectors (requires riser cards)

Expansion Board (not included)

- XAUI-RISER-B
- SGMII-PEX-RISER

Debug

- JTAG/COP
- Aurora high-speed connector

Other

- IEEE® 1588 connector for Symmetricom option card (not from Freescale)
- Temperature monitoring

Commercial Operating Systems and Tools

In addition to the SDK shipped with T4240QDS, there is a rich ecosystem of tools, debuggers, virtualization software and real-time operating system available from industry-leading suppliers including Mentor Graphics, ENEA, Green Hills Software and Wind River.

T4240 Development System



For more information visit freescale.com/QorIQ

Freescale, the Freescale logo, CodeWarrior and QorIQ are trademarks of Freescale Semiconductor, Inc., Reg. U.S. Pat. & Tm. Off. All other product or service names are the property of their respective owners. The Power Architecture and Power.org word marks and the Power and Power.org logos and related marks are trademarks and service marks licensed by Power.org. © 2014 Freescale Semiconductor, Inc

Document Number: T4240QDSFS REV 1