

A1RFRD10

REVISION RECORD				
REV	ECO	DESCRIPTION	DRFT	CHKD
▲		ADD P/N.	CV 07/21/05	
▲		ADD PART NO.	SKYCHEN 07/21/05	

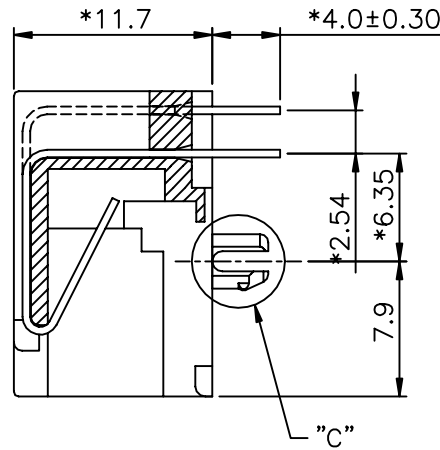

SECTION A-A

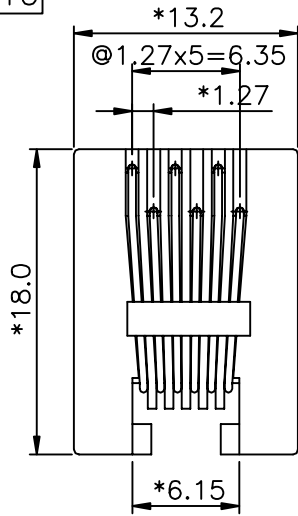
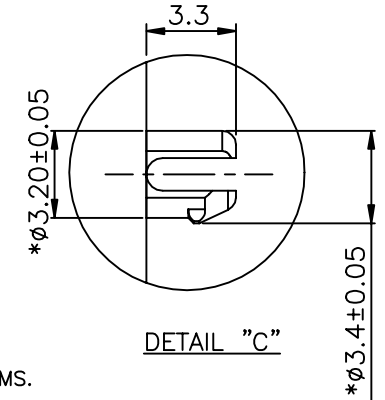
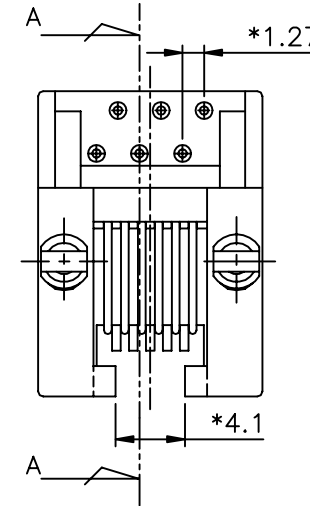

DETAIL "C"

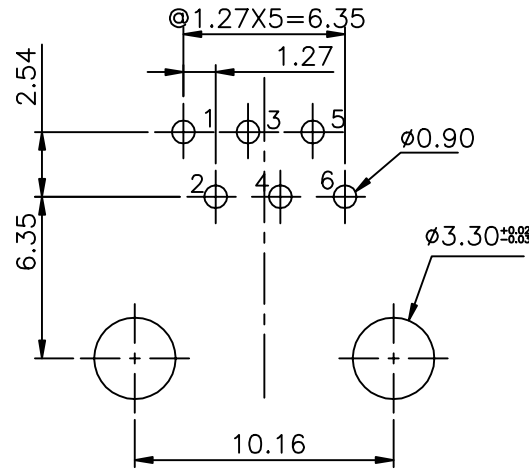
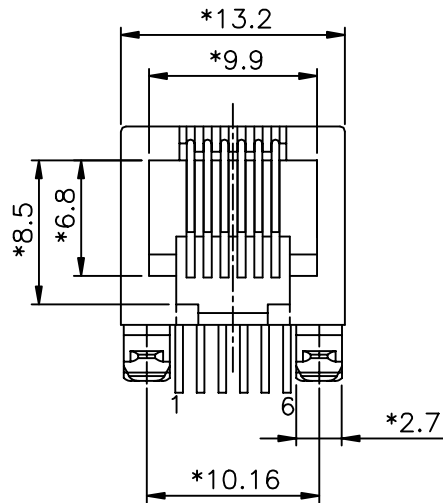

PC Board Layout
Component Side Shown

NOTES:

ELECTRICAL:

- VOLTAGE RATING : 125 VAC RMS.
- CURRENT RATING : 1.5 AMP.
- CONTACT RESISTANCE : 30 MILLIOHMS MAX.
- INSULATION RESISTANCE: 1000 MEGOHMS MIN @ 100 VDC.
- DIELECTRIC STRENGTH : 1000 VAC RMS 60Hz, 1MIN.

MECHANICAL:

- HOUSING MATERIAL : PBT+GF30% UL94V-0. COLOR:BLACK&GRAY ▲
- INSERT : PBT+GF30% UL94V-0. COLOR:BLACK&GRAY ▲
- CONTACT MATERIAL : PHOSPHOR BRONZE Ø0.46mm.
- PLATING : GOLD PLATING OVER NICKEL.
- OPERATING LIFE : 750 CYCLES MIN.
- PCB RETENTION PRE-SOLDER : 1 LB MIN.
- PCB RETENTION POST-SOLDER: 10 LBS MIN.

ENVIRONMENTAL:

- STORAGE : -40°C TO +85°C.
- OPERATION: -40°C TO +85°C.
- WAVE SOLDERING TEMPERATURE: 230°C TO 250°C (5~10 SECINDS)
- RoHS COMPLIANT.

MATES WITH MODULAR PLUG CONFORMING TO
FCC PART 68, SUBPART F.

CUL FILE NO. E163191

RoHS PART NUMBER: E536X-0001X-L

- 2- 2C
- 4- 4C
- 6- 6C
- 1- 3u" 2- 6u" 3-15u"
- 4- 30u" 5-50u"
- G - 2u"
- F - GOLD FLASH

0-PBT+GF15% BLACK
4-FR50 BLACK ▲
▲ V-PBT+GF30% COOL GRAY 1C

MM (INCH)		DFTO CXQ	DATE 04/04/05
TOLERANCES EXCEPT AS NOTED		CHKD ASHELLY	DATE 2006/7/27
		MFO	DATE
MM	±	APPV LUSHENG	DATE 2006/7/27
.0 ± 0.2	±		
.00 ± 0.15	±		
.000 ± 0.075	±		
ANGLES ± 0.5		QTY :	
THIRD ANGLE PROJECTION		FINISH :	
		SCALE : 5:4	

Pulse A TECHNOLOGY COMPANY **RoHS Compliant**

FULL RISE ELECTRONIC CO., LTD

TITLE
90° VERY L/P PCB JACK 6P

DRAWING NO. GE533077-LC SIZE A3 REV 2
/PART NO. SEE NOTE

DO NOT SCALE DRAWING SHEET 1 OF 1