

REVISONS		DATE	BY	APPV
NO	DESCRIPTION			
G	REV PER ECO 15-005906	5-19-15	CT	DM

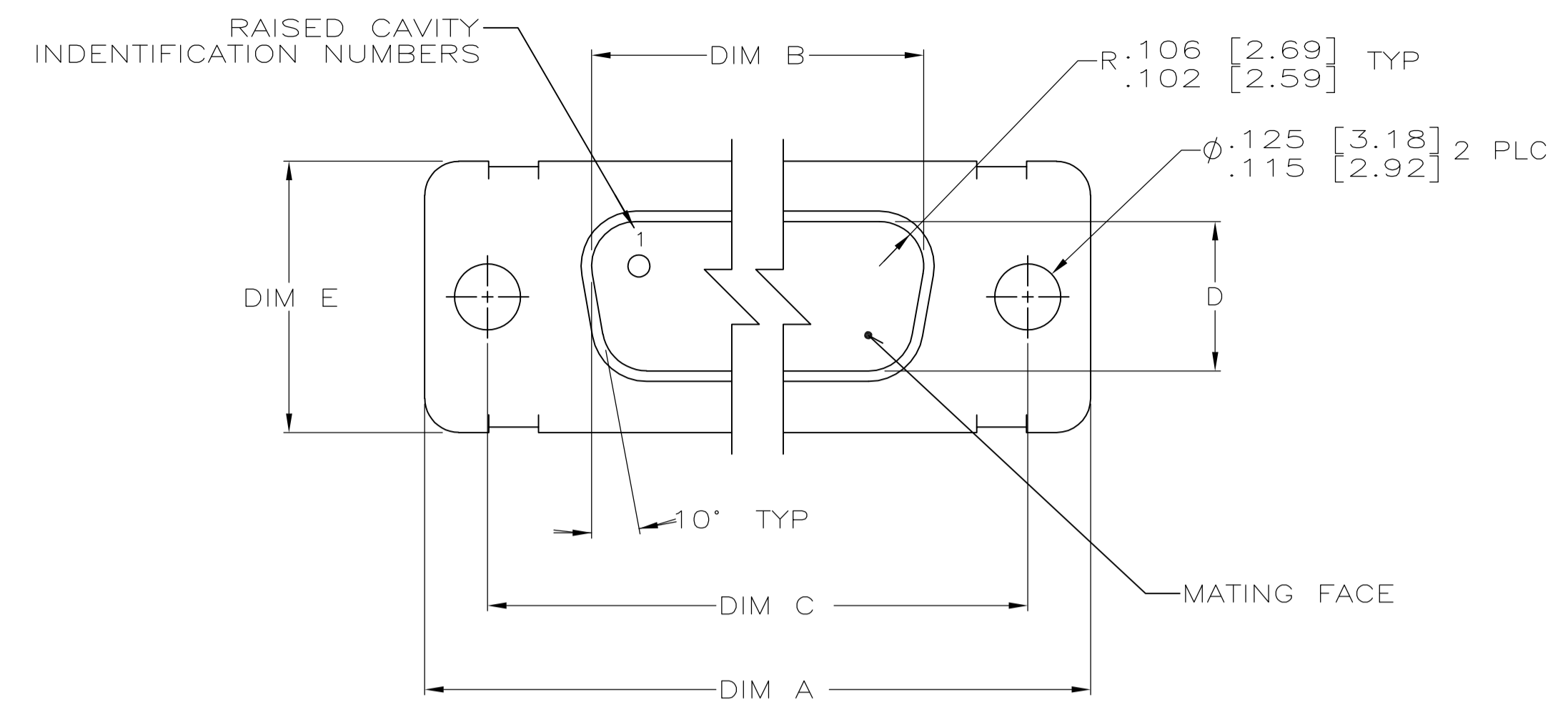

- THE CONNECTORS DESCRIBED IN THIS DOCUMENT MATE WITH ANY RECEPTACLE CONNECTOR WITH THE SAME INSERT ARRANGEMENT.
- MARKED WITH .047 [1.19]-.062 [1.57] HIGH CHARACTERS. FAR SIDE REFERS TO THE WIDE SIDE OF THE KEYSTONE. NEAR SIDE REFERS TO THE NARROW SIDE OF THE KEYSTONE. IF THE FRONT SHELL IS TOO SMALL FOR "MFG'S"(NAME, BRAND OR LOGO), MFG'S PART NUMBER AND DATE CODE, THEN SPLIT AS FOLLOWS:
 - MFG'S PART NUMBER ON REAR SHELL, FAR SIDE.
 - "MFG'S" (NAME, BRAND OR LOGO) AND DATE CODE ON FRONT SHELL, FAR SIDE.

MARK MFG'S(NAME, BRAND OR LOGO), MFG'S PART NO AND DATE CODE, FAR SIDE.

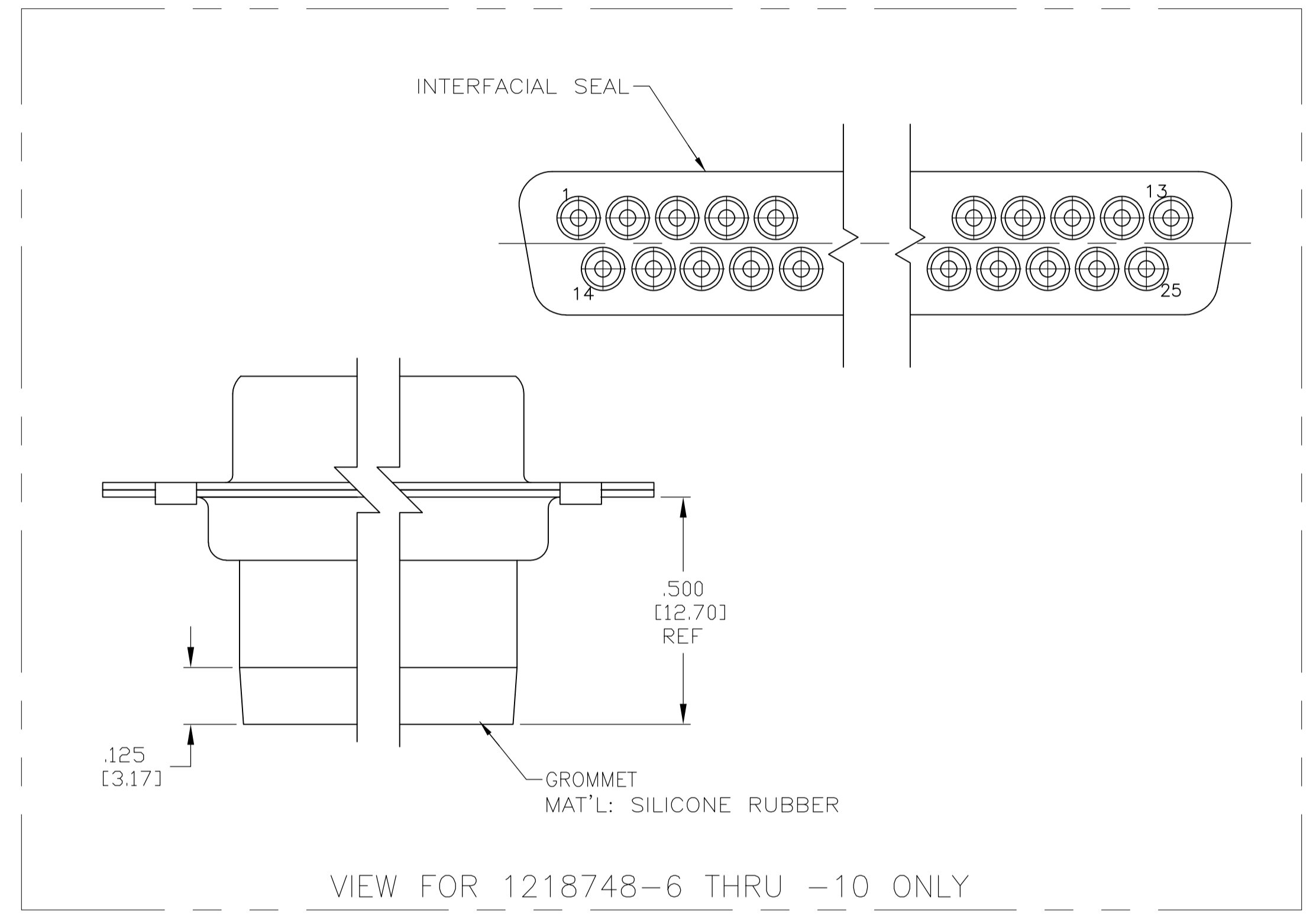
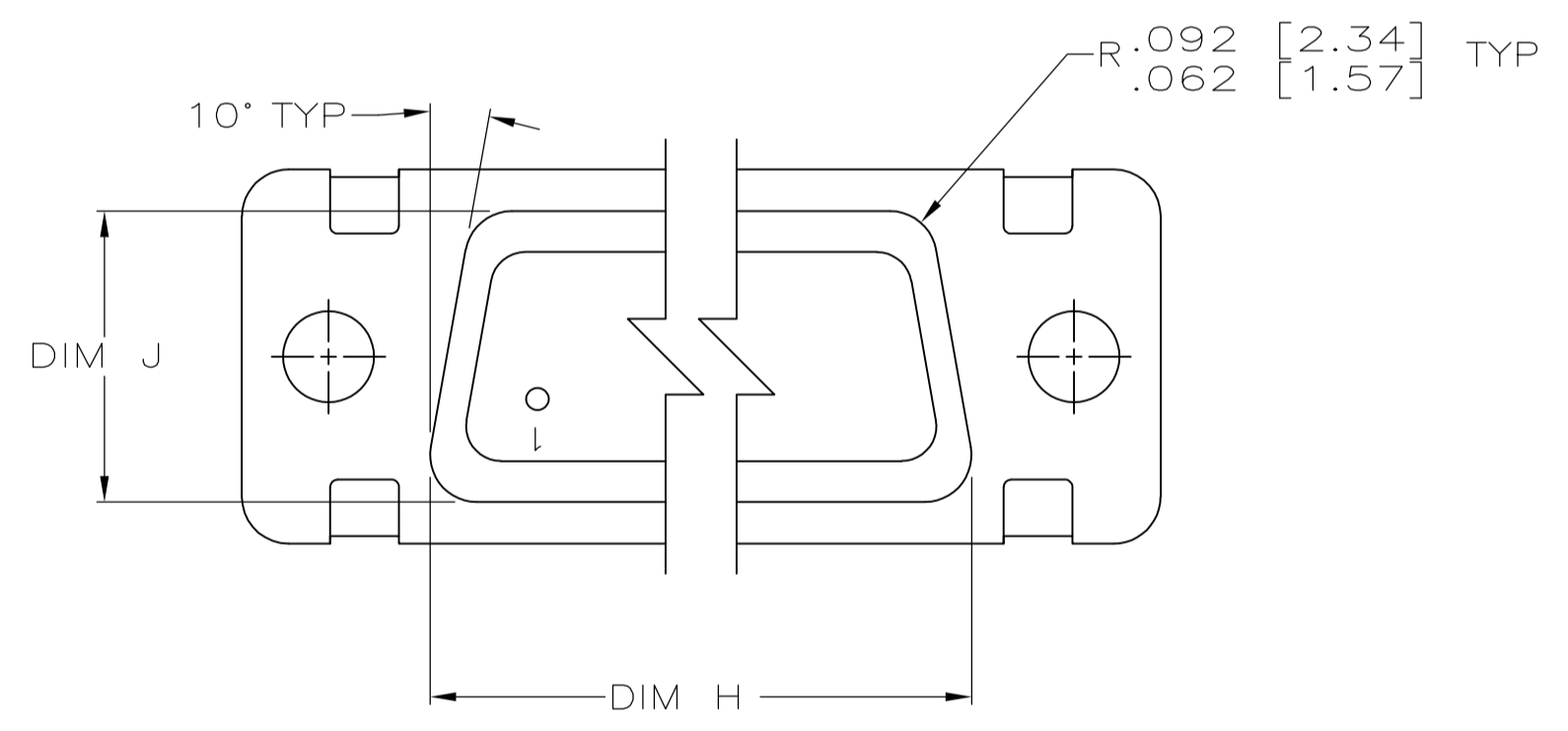
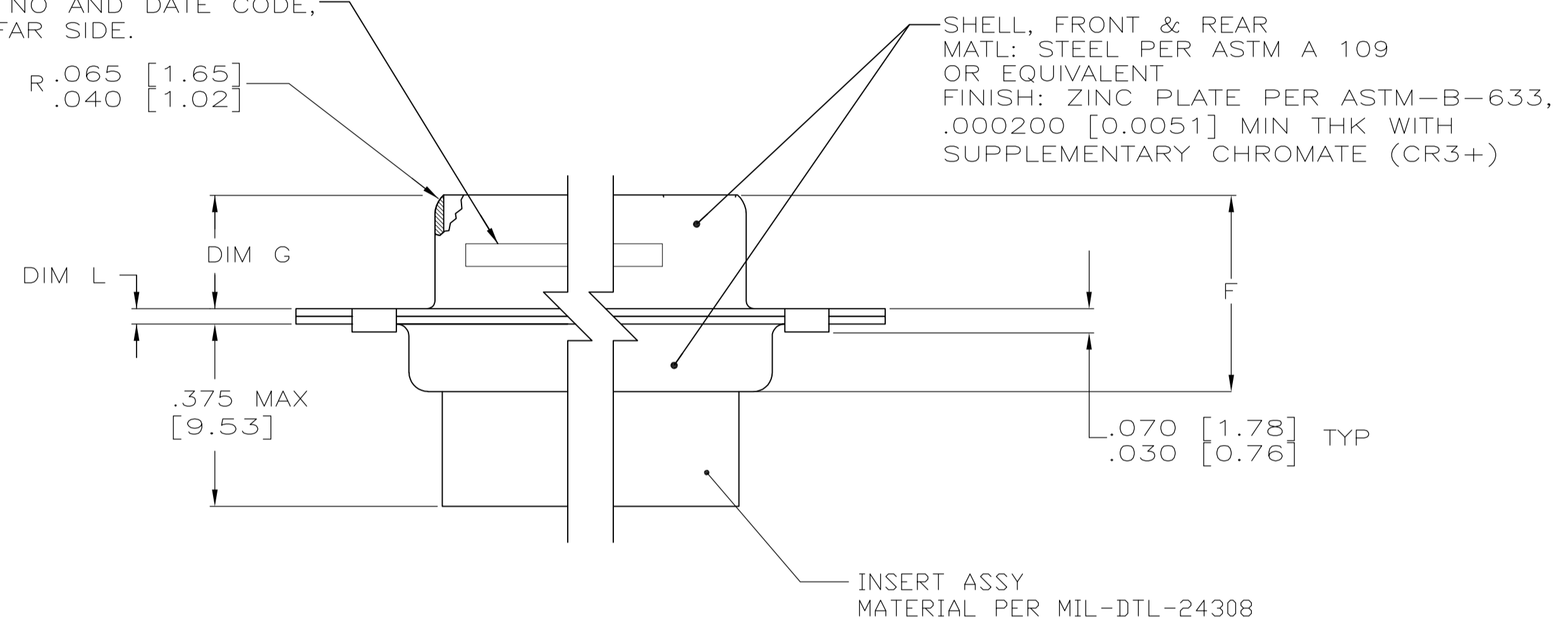

PRELIMINARY NOT RELEASED FOR PRODUCTION	WITH GROMMET & INTERFACIAL SEAL	.049 [1.24]	.544 [13.82]	2.188 [55.58]	.238 [6.05]	.436 [11.07]	.620 [15.75]	.446 [11.33]	2.411 [61.24]	2.084 [52.93]	2.650 [67.31]	MS18277-1	50	5	1-1218748-0
PRELIMINARY NOT RELEASED FOR PRODUCTION	WITH GROMMET & INTERFACIAL SEAL	.049 [1.24]	.432 [10.97]	2.282 [57.96]	.238 [6.05]	.436 [11.07]	.509 [12.93]	.334 [8.48]	2.505 [63.63]	2.187 [55.55]	2.744 [69.70]	MS18276-1	37	4	1218748-9
PRELIMINARY NOT RELEASED FOR PRODUCTION	WITH GROMMET & INTERFACIAL SEAL	.049 [1.24]	.432 [10.97]	1.635 [41.53]	.238 [6.05]	.436 [11.07]	.509 [12.93]	.334 [8.48]	1.857 [47.17]	1.539 [39.09]	2.103 [53.42]	MS18275-1	25	3	1218748-8
PRELIMINARY NOT RELEASED FOR PRODUCTION	WITH GROMMET & INTERFACIAL SEAL	.040 [1.02]	.432 [10.97]	1.093 [27.76]	.238 [6.05]	.432 [10.97]	.509 [12.93]	.334 [8.48]	1.317 [33.45]	.999 [25.37]	1.556 [39.52]	MS18274-1	15	2	1218748-7
PRELIMINARY NOT RELEASED FOR PRODUCTION	WITH GROMMET & INTERFACIAL SEAL	.040 [1.02]	.432 [10.97]	.769 [19.53]	.238 [6.05]	.432 [10.97]	.509 [12.93]	.334 [8.48]	.989 [25.12]	.671 [17.04]	1.228 [31.19]	MS18273-1	9	1	1218748-6
-	-	.049 [1.24]	.544 [13.82]	2.188 [55.58]	.238 [6.05]	.436 [11.07]	.620 [15.75]	.446 [11.33]	2.411 [61.24]	2.084 [52.93]	2.650 [67.31]	MS18277-1	50	5	1218748-5
-	-	.049 [1.24]	.432 [10.97]	2.282 [57.96]	.238 [6.05]	.436 [11.07]	.509 [12.93]	.334 [8.48]	2.505 [63.63]	2.187 [55.55]	2.744 [69.70]	MS18276-1	37	4	1218748-4
-	-	.049 [1.24]	.432 [10.97]	1.635 [41.53]	.238 [6.05]	.436 [11.07]	.509 [12.93]	.334 [8.48]	1.857 [47.17]	1.539 [39.09]	2.103 [53.42]	MS18275-1	25	3	1218748-3
-	-	.040 [1.02]	.432 [10.97]	1.093 [27.76]	.238 [6.05]	.432 [10.97]	.509 [12.93]	.334 [8.48]	1.317 [33.45]	.999 [25.37]	1.556 [39.52]	MS18274-1	15	2	1218748-2
-	-	.040 [1.02]	.432 [10.97]	.769 [19.53]	.238 [6.05]	.432 [10.97]	.509 [12.93]	.334 [8.48]	.989 [25.12]	.671 [17.04]	1.228 [31.19]	MS18273-1	9	1	1218748-1
REMARKS		L	J	H	G	F	E	D	C	B	A	INSERT ARRANGEMENT	NO OF POS	SHELL SIZE	PART NUMBER

THIS DRAWING IS A CONTROLLED DOCUMENT.

DIMENSIONS: INCHES. TOLERANCES UNLESS OTHERWISE SPECIFIED:

0 PLC	± .005
1 PLC	± .004
2 PLC	± .003
3 PLC	± .002
4 PLC	± .001
ANGLES	± .001

MATERIAL: SEE CALLOUTS. FINISH: SEE CALLOUTS.

WEIGHT: —. CUSTOMER DRAWING: A1 00779. SCALE: 4:1. SHEET: 1 OF 1. REV: G.

STE TE Connectivity. PLUG ASSY,AMPLIMITE,SERIES 109, SIZE 20,ZINC PLATED.