

## **OPA521EVM User's Guide**

---

---

This user's guide describes the characteristics, operation and use of the OPA521 evaluation module (EVM). It discusses how to set up and configure the board hardware, and describes various applications using the evaluation module. Throughout this document the terms evaluation board, evaluation module, and EVM are synonymous with the OPA521EVM. This document also includes an electrical schematic, printed circuit board (PCB) layout drawing, and a parts list for the EVM.

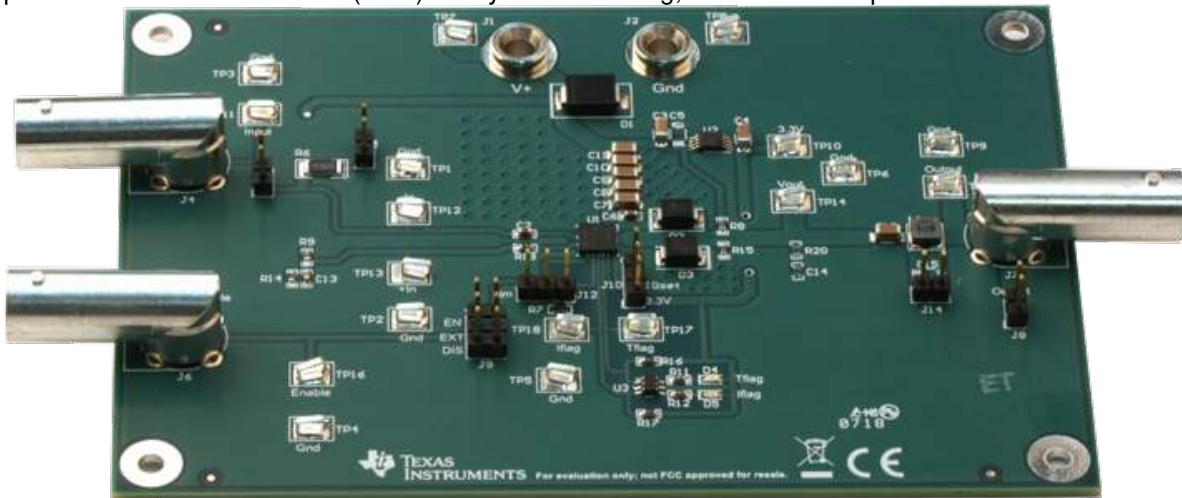

### Contents

1	Overview .....	3
2	Schematic and Layout .....	6
3	Getting Started .....	7
4	Appendix .....	8

### List of Figures

1	OPA521 Device Functional Block Diagram .....	3
2	OPA521EVM Partial Schematic .....	6
3	OPA521EVM Schematic .....	8

### List of Tables

1	OPA521EVM Jumper Description .....	5
2	LED Light Indicators .....	5
3	OPA521 EVM Bill of Materials .....	9

### Trademarks

All trademarks are the property of their respective owners.

## 1 Overview

### 1.1 General Information About the OPA521

The OPA521 is a 24-V power operational amplifier (PA) with high slew rate capable of driving up to 1.9 A continuous output current over the specified junction temperature range of  $-40^{\circ}\text{C}$  to  $+125^{\circ}\text{C}$ . This amplifier offers an adjustable current limit, a thermal shutdown indicator, and enable/shutdown features. The PA is configured with an inverting gain of 7 V/V, has a low-pass filter response, and maintains excellent linearity and low distortion throughout its bandwidth. The PA block is shown in [Figure 1](#).

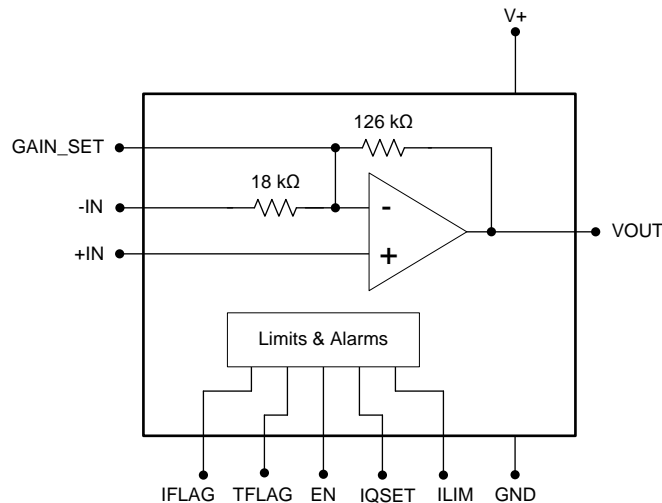

**Figure 1. OPA521 Device Functional Block Diagram**

The OPA521 can be used as a line driver for narrow band power line communications (PLC).

### 1.2 High Power Warning

#### **CAUTION**

The OPA521 evaluation module contains a high voltage, high current power amplifier. Please use precautions when operating the OPA521 EVM.

The possibility for accidental electrical shock increases with increased potential difference and the user must take precautions to avoid contact with the PC board when live voltage is present. If circuit probing is required and voltages are present, it is a best practice to apply the “one hand rule.” Use an insulated probe and only one hand when probing the live circuit. Keep the other hand away from the circuit and any metal contacts in the immediate area through which current could flow.

Power operational amplifiers can generate a lot of heat under some operating conditions. That excess heat must be conducted away from amplifier in order to assure correct operation and long life. A passive heat sink, or heat sink/fan assembly, may be employed. Heat sinks can become hot to the touch if the power being dissipated as heat is high relative to the heat sink’s ability to dissipate it. When that occurs contacting the heat sink with bare skin may cause a user to become startled, or possibly receive a burn. Therefore, it is best to avoid any contact with the heat sink when the circuit is in use, or cooling down after use.

### 1.3 General Information About the OPA521EVM

This EVM configures the OPA521 device in an ac-coupled inverting amplifier allowing users to easily evaluate the drive capability of the device. The EVM is based on a 5-inch × 3.5-inch (12.7-cm × 8.9-cm) PC board that accommodates the QFN-20 package with bottom side power pad.

An illuminated red LED (D4) indicates that the OPA521 is operating normally and when turned off it indicates that the device is in thermal shutdown. When off a red LED (D5) indicates the OPA521 output is current limited. The output current limits can be selected by positioning the shunt on jumper JMP4 (J12) to ground for maximum current output or to R10 which can be populated to the appropriate value with the equations in [Equation 2](#).

### 1.4 Supply Voltage Considerations for the OPA521EVM

The OPA521 device is able to operate with a single supply, ground, and V<sub>+</sub> (7 V -24 V). Although the supply range of the OPA521 device can operate up to 24-V single supply, the EVM has been designed to be used up to 17.8-V single supply range due to the TVS diode (D1) attached on the supply to ground (see [Section 1.5](#)).

Two PA power-supply pins and two PA ground pins are available to provide a path for the high currents associated with driving the low impedance of the ac mains. Connecting the three PA supply pins together is recommended. TI also recommends placing a 47- $\mu$ F to 100- $\mu$ F bypass capacitor in parallel with a 100-nF capacitor as close as possible to the device. Take care when routing the high-current ground lines on the PCB to avoid creating voltage drops in the PCB ground that may vary with changes in load current.

The OPA521 operational amplifier also requires a digital supply voltage between 2 V and 5.5 V above the negative supply applied to the amplifier. A fixed output regulator TPS7A1633 was used on the EVM for a 3.3-V supply to fulfill this requirement.

### 1.5 Input, Output, and Power Supply Protection

Power-line communications are frequently harsh operating environment for electrical components connected to the ac line. Noise or surges from electrical anomalies such as lightning, capacitor bank switching, inductive switching, or other grid fault conditions can damage high-performance integrated circuits if they are not properly protected. The OPA521 can survive even these harsh conditions, but several simple recommendations must be followed. One recommendation is to clamp as much of the electrical disturbance before it reaches the OPA521 device with a multi-layer approach using metal-oxide varistors (MOVs), transient voltage suppression diodes (TVSs), Schottky diodes, and a zener diode.

This EVM has current-steering diodes (B130-13-F), D2 and D3, which were placed at the output of the OPA521. In the unlikely event a transient surge increases the output pin of the PA beyond its power-supply rail, low-drop Schottky diodes can steer the current around the OPA521 to ground. Maintaining a low forward voltage drop on the Schottky diode is recommended for maximum protection. If the Schottky diode that connects the output of the PA to the power-supply rail turns on and becomes forward-biased, it is important to steer the current to ground without significantly disturbing the PA power-supply voltage. Placing a zener or transient voltage suppressor (TVS) diode at the PA power-supply pins to ground provides a low-impedance path for surges that attempt to raise the power-supply voltage beyond the absolute maximum rated voltage for the OPA521.

The OPA521EVM has a TVS diode (SMCJ16A-TP) populated in socketD1. When choosing a suitable TVS or zener-diode, several points must be considered – such as the power supply voltage levels during normal operation and the expected electrical overstress (EOS). TVS diode was used on D1 and limits the operating supply to a maximum limit of 15 V. D1 can be replaced with a TVS diode with A procedure how to select a well-fitting TVS can be found in the following blog: [Electrical overstress in a nutshell](#).

## 1.6 Jumpers

A brief description of the basic jumper functions is shown in [Table 1](#). More information can be found in [Section 3](#).

**Table 1. OPA521EVM Jumper Description**

JUMPER	DESCRIPTION
JMP1 (J5)	Connects BNC input connector (J4) to AC coupled inverting input (-IN) of the OPA521
JMP2 (J3)	50-Ω termination when jumper is shorted
JMP3 (J10)	Device Enable pin has 3 options: Enable (EN), Disable (DIS), or using an external signal generator (EXT) to toggle the pin.
JMP4 (J12)	Setting current limit to maximum by grounding ILIM pin or setting limit with resistor R10.
JMP5 (J11)	Quiescent current select (active high, high configures the OPA521 to operate in FCC/ARIB bands, low configures the OPA521 to operate in CENELEC Bands A, B, C, D)
JMP6 (J7)	Bypass L1 when jumper is shorted
JMP7 (J9)	Used to probe the AC coupled output of OPA521

## 1.7 LEDs

[Table 2](#) explains how to interpret the LEDs when they are not illuminated. More details can be found in [Section 3](#).

**Table 2. LED Light Indicators**

LED(s)	DESCRIPTION
D4 (Tflag)	Thermal limit warning flag (when tripped the LED light turns off)
D5 (Iflag)	Current limit warning flag (when tripped the LED light turns off)

## 2 Schematic and Layout

### 2.1 Schematics

Figure 2 shows the main circuitry of the EVM amplifier. The complete schematic for the EVM including the digital, enable/shutdown and LED circuits can be found in .

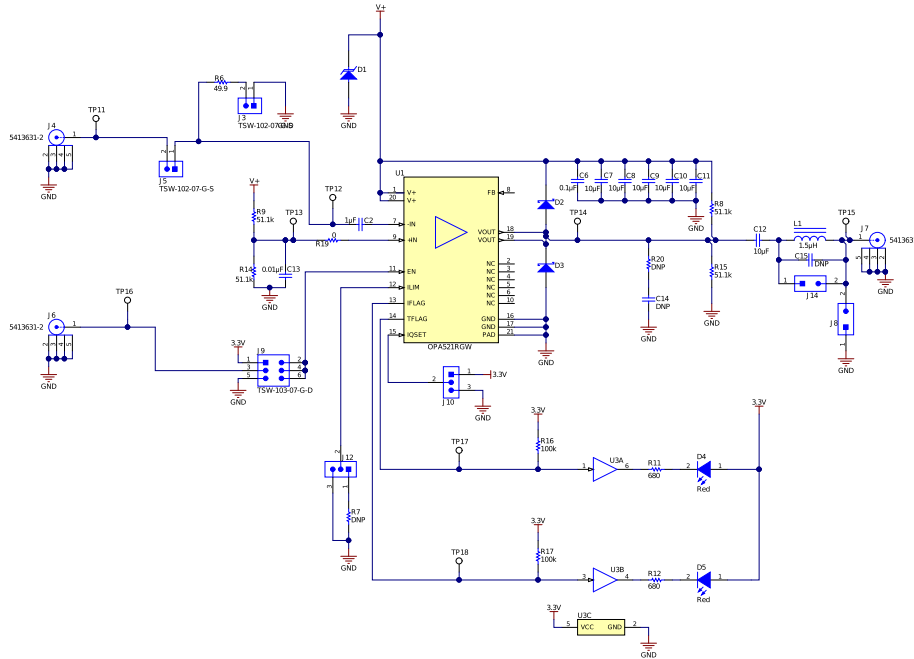

Copyright © 2018, Texas Instruments Incorporated

Figure 2. OPA521EVM Partial Schematic

## 2.2 Input AC-Coupled Capacitor

The input capacitor ( $C_{IN}$ ) on the OPA521EVM introduces a single-pole, high-pass characteristic to the PA transfer function. The  $C_{IN}$  and PA combination has a band-pass response because of the inherent low-pass transfer function from the PA. The value of the high-pass cutoff frequency is determined by  $C_{IN}$  reacting with the input resistance of the PA circuit, and can be determined by Equation 1:

$$C_{in} = \frac{1}{2 \times \pi \times 18k \times f_{HP}}$$

where

- $C_{IN}$  = external input capacitor
  - $f_{HP}$  = desired high-pass cutoff frequency
- (1)

For example, setting  $C_{IN}$  to 3.3 nF results in a high-pass cutoff frequency of 2.9 kHz. Determine the voltage rating for  $C_{IN}$  to withstand operation up to the PA power-supply voltage.

## 2.3 Current Limit $R_{SET}$ Value

The ILIM pin (pin 12) provides a resistor-programmable output current limit for the PA block. Equation 2 determines the value of the external RSET resistor attached to this pin. where:

$$I_{LIM} = \frac{1.2V \times 16.320k\Omega}{8k\Omega + R_{SET}}$$

where

- $I_{LIM}$  = the value of the desired current limit for the PA
  - $R_{SET}$  = the value of the external resistor connected between pin 12 and ground,
- (2)

## 3 Getting Started

This section explains the purpose of the connectors and jumpers, how to configure the EVM and how to make use of the features provided by the EVM.

### 3.1 Power Supply

The OPA521EVM is configured only use a single 7-V to 24-V supply, power is provided to the EVM through 2 banana jacks: AVDD and GND. The power supply must provide the total anticipated current required in the application. The OPA521 can supply a continuous dc current of 1.9 A, but it is recommended that the supply should be capable of providing at least 2× the anticipated continuous current to account for peak current conditions. Make sure any cables used to carry high current are rated for such service.

Even though the OPA521 operational amplifier is specified for an absolute maximum supply voltage of 26 V, TI recommends that not more than 25 V be applied to the EVM to avoid damage to other parts. For this reason TVS diode is attached from supply to ground and limits the operating supply to 18V maximum.

### 3.2 Inputs

The input to the EVM must be an AC signal source such as a signal generator. Note that 50-Ω termination resistors R1 can be utilized on the EVM by placing a short bar on JMP2 (J3). Excessive power dissipation, under high input voltage conditions, could result in their failure and destruction. The signal presented to the inverting OPA521 input pin –IN is selected through JMP1 (J5).

### 3.3 Outputs

Output signals derived from the EVM may be monitored by whatever means required by the user. Often, an oscilloscope provides a convenient way to observe the output waveform from the OPA521. The output is brought to a BNC connector (J6) which is intended for the instrument connection and to carry high output current. The load is intended to be located external to the EVM. The OPA521 can drive a variety of load types which includes resistors, motors, transducers, etc. some of which may have to dissipate significant power, or be physically too large to reside on the EVM.

### 3.4 Enable/Disable Feature

The EVM provides a means to test the enable/disable functionality of the OPA521 with jumper JMP3 (J10). JMP3 (J10) allows 3 options for placing a shorting bar jumper, that allow the user to Enable, Disable, or use an external waveform generator.

### 3.5 Current Limitation Capability

The OPA521 EVM provides means to limit the maximum output current that it can provide. A resistance between the ground and the amplifier's ILIM pin is used to set the maximum output current limit. This resistance can be utilized by JMP4 (J12) to set the current limit by positioning the jumper to utilize R10. As an example, if the designer wants to limit the output current to 1 A, then R10 must be populated with a resistance of 11.584 kΩ which using standard resistance values is approximately 11.5 Ω.

### 3.6 LED Indicator

The LED indicators are explained in and [Section 1.3](#).

## 4 Appendix

[Figure 3](#) shows the complete schematics of the OPA521 EVM. The bill of materials is shown in [Table 3](#).

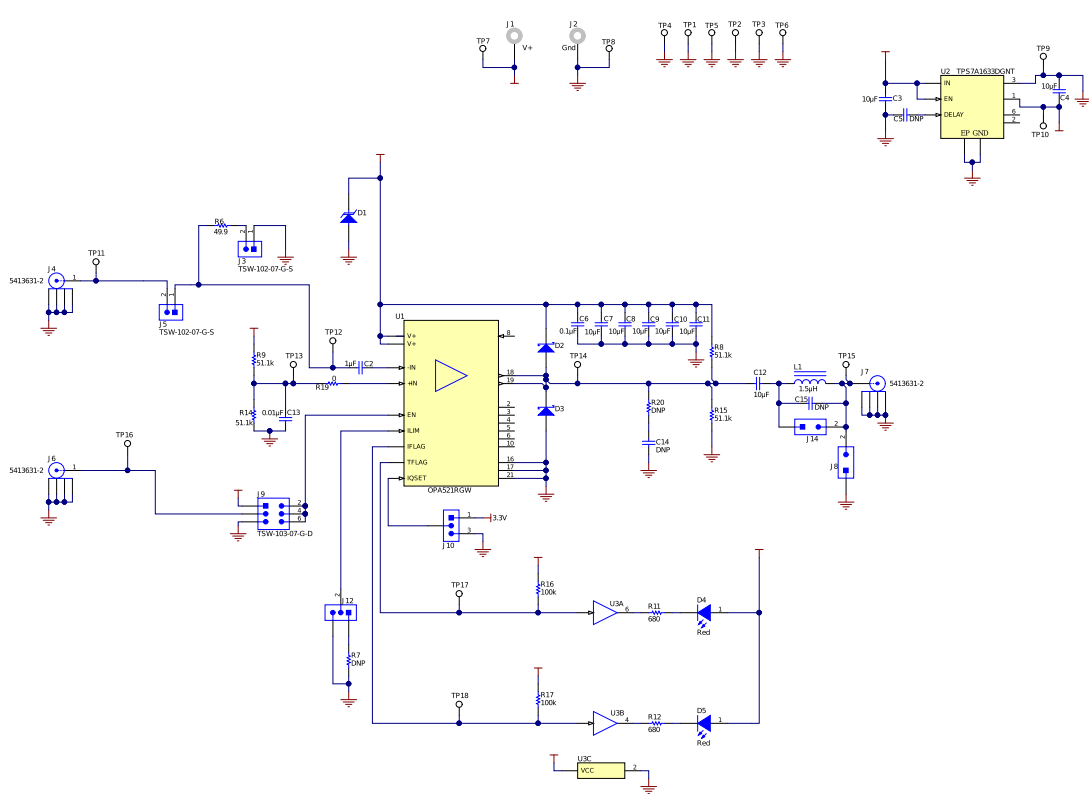

Copyright © 2018, Texas Instruments Incorporated

**Figure 3. OPA521EVM Schematic**



**Table 3. OPA521 EVM Bill of Materials**

Item #	Designator	Quantity	Value	Part Number	Manufacturer	Description	Package Reference
1	C2, C14	2	1uF	C1608X5R1H105K080A B	TDK	CAP, CERM, 1 μF, 50 V,+/- 10%, X5R, 0603	0603
2	C3, C4, C5, C7, C8, C9, C10, C11, C12, C15	10	10uF	C3216X5R1H106K160A B	TDK	CAP, CERM, 10 μF, 50 V,+/- 10%, X5R, 1206	1206
3	C6	1	0.1uF	GCM188R71H104KA57 D	MuRata	CAP, CERM, 0.1 μF, 50 V,+/- 10%, X7R, 0603	0603
4	C13	1	0.01uF	C0603C103J5RACTU	Kemet	CAP, CERM, 0.01 μF, 50 V,+/- 5%, X7R, 0603	0603
5	D1	1	160V	SMCJ160A-TP	Micro Commercial Components	Diode, TVS, Uni, 160 V, 259 Vc, SMC	SMC
6	D2, D3	2	30V	B130B-13-F	Diodes Inc.	Diode, Schottky, 30 V, 1 A, SMB	SMB
7	D4, D5	2	Red	LTST-C191KRKT	Lite-On	LED, Red, SMD	LED_0603
8	FID1, FID2, FID3	3		N/A	N/A	Fiducial mark. There is nothing to buy or mount.	N/A
9	H1, H2, H3, H4	4		PMSSS 440 0025 PH	B&F Fastener Supply	Machine Screw, Round, #4-40 x 1/4, Stainless Steel, Phillips panhead	Screw
10	H5, H6, H7, H8	4		2203	Keystone	Standoff, Hex, 0.5"L #4-40 Stainless Steel	Standoff
11	J1, J2	2		575-4	Keystone	Standard Banana Jack, Uninsulated, 5.5mm	Keystone_575-4
12	J3, J5, J8, J14	4		TSW-102-07-G-S	Samtec	Header, 100mil, 2x1, Gold, TH	2x1 Header
13	J4, J6, J7	3		5413631-2	AMP	Connector, TH, BNC Right angle, 50 ohm gold	5413631-2
14	J9	1		TSW-103-07-G-D	Samtec	Header, 100mil, 3x2, Gold, TH	3x2 Header
15	J10, J12	2		TSW-103-07-G-S	Samtec	Header, 100mil, 3x1, Gold, TH	3x1 Header
16	L1	1	1.5uH	744031001	Würth Elektronik	Inductor, Shielded Drum Core, Ferrite, 1.5 μH, 1.55 A, 0.04 ohm, SMD	WE-TPC-S
17	LBL1	1		THT-14-423-10	Brady	Thermal Transfer Printable Labels, 0.650" W x 0.200" H - 10,000 per roll	PCB Label 0.650 x 0.200 inch
18	R6	1	49.9	CRCW201049R9FKEF	Vishay-Dale	RES, 49.9, 1%, 0.75 W, AEC- Q200 Grade 0, 2010	2010

**Table 3. OPA521 EVM Bill of Materials (continued)**

Item #	Designator	Quantity	Value	Part Number	Manufacturer	Description	Package Reference
19	R7, R11, R12	3	49.9k	CRCW060349K9FKEA	Vishay-Dale	RES, 49.9 k, 1%, 0.1 W, 0603	0603
20	R8, R9, R14, R15	4	51.1k	CRCW060351K1FKEA	Vishay-Dale	RES, 51.1 k, 1%, 0.1 W, 0603	0603
21	R16, R17	2	100k	CRCW0603100KFKEA	Vishay-Dale	RES, 100 k, 1%, 0.1 W, 0603	0603
22	R19, R20	2	0	CRCW06030000Z0EA	Vishay-Dale	RES, 0, 5%, 0.1 W, 0603	0603
23	TP1, TP2, TP3, TP4, TP5, TP6, TP7, TP8, TP9, TP10, TP11, TP12, TP13, TP14, TP15, TP16, TP17, TP18	18		5016	Keystone	Test Point, Compact, SMT	Testpoint_Keystone_Compact
24	U1	1		OPA521RGW	Texas Instruments	Power-Line Communications Line Driver, RGW0020A (VQFN-20)	RGW0020A
25	U2	1		TPS7A1633DGNT	Texas Instruments	Single Output LDO, 100 mA, Fixed 3.3 V Output, 3 to 60 V Input, with Enable and Power Good, 8-pin MSOP (DGN), -40 to 125 degC, Green (RoHS & no Sb/Br)	DGN0008C
26	U3	1		SN74LVC2G07DBVR	Texas Instruments	Dual Buffer/Driver with Open-Drain Output, DBV0006A, LARGE T&R	DBV0006A

## STANDARD TERMS FOR EVALUATION MODULES

1. *Delivery:* TI delivers TI evaluation boards, kits, or modules, including any accompanying demonstration software, components, and/or documentation which may be provided together or separately (collectively, an "EVM" or "EVMs") to the User ("User") in accordance with the terms set forth herein. User's acceptance of the EVM is expressly subject to the following terms.
  - 1.1 EVMs are intended solely for product or software developers for use in a research and development setting to facilitate feasibility evaluation, experimentation, or scientific analysis of TI semiconductor products. EVMs have no direct function and are not finished products. EVMs shall not be directly or indirectly assembled as a part or subassembly in any finished product. For clarification, any software or software tools provided with the EVM ("Software") shall not be subject to the terms and conditions set forth herein but rather shall be subject to the applicable terms that accompany such Software
  - 1.2 EVMs are not intended for consumer or household use. EVMs may not be sold, sublicensed, leased, rented, loaned, assigned, or otherwise distributed for commercial purposes by Users, in whole or in part, or used in any finished product or production system.
2. *Limited Warranty and Related Remedies/Disclaimers:*
  - 2.1 These terms do not apply to Software. The warranty, if any, for Software is covered in the applicable Software License Agreement.
  - 2.2 TI warrants that the TI EVM will conform to TI's published specifications for ninety (90) days after the date TI delivers such EVM to User. Notwithstanding the foregoing, TI shall not be liable for a nonconforming EVM if (a) the nonconformity was caused by neglect, misuse or mistreatment by an entity other than TI, including improper installation or testing, or for any EVMs that have been altered or modified in any way by an entity other than TI, (b) the nonconformity resulted from User's design, specifications or instructions for such EVMs or improper system design, or (c) User has not paid on time. Testing and other quality control techniques are used to the extent TI deems necessary. TI does not test all parameters of each EVM. User's claims against TI under this Section 2 are void if User fails to notify TI of any apparent defects in the EVMs within ten (10) business days after delivery, or of any hidden defects with ten (10) business days after the defect has been detected.
  - 2.3 TI's sole liability shall be at its option to repair or replace EVMs that fail to conform to the warranty set forth above, or credit User's account for such EVM. TI's liability under this warranty shall be limited to EVMs that are returned during the warranty period to the address designated by TI and that are determined by TI not to conform to such warranty. If TI elects to repair or replace such EVM, TI shall have a reasonable time to repair such EVM or provide replacements. Repaired EVMs shall be warranted for the remainder of the original warranty period. Replaced EVMs shall be warranted for a new full ninety (90) day warranty period.
3. *Regulatory Notices:*
  - 3.1 *United States*
    - 3.1.1 *Notice applicable to EVMs not FCC-Approved:*

**FCC NOTICE:** This kit is designed to allow product developers to evaluate electronic components, circuitry, or software associated with the kit to determine whether to incorporate such items in a finished product and software developers to write software applications for use with the end product. This kit is not a finished product and when assembled may not be resold or otherwise marketed unless all required FCC equipment authorizations are first obtained. Operation is subject to the condition that this product not cause harmful interference to licensed radio stations and that this product accept harmful interference. Unless the assembled kit is designed to operate under part 15, part 18 or part 95 of this chapter, the operator of the kit must operate under the authority of an FCC license holder or must secure an experimental authorization under part 5 of this chapter.
    - 3.1.2 *For EVMs annotated as FCC – FEDERAL COMMUNICATIONS COMMISSION Part 15 Compliant:*

### CAUTION

This device complies with part 15 of the FCC Rules. Operation is subject to the following two conditions: (1) This device may not cause harmful interference, and (2) this device must accept any interference received, including interference that may cause undesired operation.

Changes or modifications not expressly approved by the party responsible for compliance could void the user's authority to operate the equipment.

### FCC Interference Statement for Class A EVM devices

*NOTE: This equipment has been tested and found to comply with the limits for a Class A digital device, pursuant to part 15 of the FCC Rules. These limits are designed to provide reasonable protection against harmful interference when the equipment is operated in a commercial environment. This equipment generates, uses, and can radiate radio frequency energy and, if not installed and used in accordance with the instruction manual, may cause harmful interference to radio communications. Operation of this equipment in a residential area is likely to cause harmful interference in which case the user will be required to correct the interference at his own expense.*

## FCC Interference Statement for Class B EVM devices

*NOTE: This equipment has been tested and found to comply with the limits for a Class B digital device, pursuant to part 15 of the FCC Rules. These limits are designed to provide reasonable protection against harmful interference in a residential installation. This equipment generates, uses and can radiate radio frequency energy and, if not installed and used in accordance with the instructions, may cause harmful interference to radio communications. However, there is no guarantee that interference will not occur in a particular installation. If this equipment does cause harmful interference to radio or television reception, which can be determined by turning the equipment off and on, the user is encouraged to try to correct the interference by one or more of the following measures:*

- Reorient or relocate the receiving antenna.
- Increase the separation between the equipment and receiver.
- Connect the equipment into an outlet on a circuit different from that to which the receiver is connected.
- Consult the dealer or an experienced radio/TV technician for help.

### 3.2 Canada

3.2.1 For EVMs issued with an Industry Canada Certificate of Conformance to RSS-210 or RSS-247

#### Concerning EVMs Including Radio Transmitters:

This device complies with Industry Canada license-exempt RSSs. Operation is subject to the following two conditions:

(1) this device may not cause interference, and (2) this device must accept any interference, including interference that may cause undesired operation of the device.

#### Concernant les EVMs avec appareils radio:

Le présent appareil est conforme aux CNR d'Industrie Canada applicables aux appareils radio exempts de licence. L'exploitation est autorisée aux deux conditions suivantes: (1) l'appareil ne doit pas produire de brouillage, et (2) l'utilisateur de l'appareil doit accepter tout brouillage radioélectrique subi, même si le brouillage est susceptible d'en compromettre le fonctionnement.

#### Concerning EVMs Including Detachable Antennas:

Under Industry Canada regulations, this radio transmitter may only operate using an antenna of a type and maximum (or lesser) gain approved for the transmitter by Industry Canada. To reduce potential radio interference to other users, the antenna type and its gain should be so chosen that the equivalent isotropically radiated power (e.i.r.p.) is not more than that necessary for successful communication. This radio transmitter has been approved by Industry Canada to operate with the antenna types listed in the user guide with the maximum permissible gain and required antenna impedance for each antenna type indicated. Antenna types not included in this list, having a gain greater than the maximum gain indicated for that type, are strictly prohibited for use with this device.

#### Concernant les EVMs avec antennes détachables

Conformément à la réglementation d'Industrie Canada, le présent émetteur radio peut fonctionner avec une antenne d'un type et d'un gain maximal (ou inférieur) approuvé pour l'émetteur par Industrie Canada. Dans le but de réduire les risques de brouillage radioélectrique à l'intention des autres utilisateurs, il faut choisir le type d'antenne et son gain de sorte que la puissance isotrope rayonnée équivalente (p.i.r.e.) ne dépasse pas l'intensité nécessaire à l'établissement d'une communication satisfaisante. Le présent émetteur radio a été approuvé par Industrie Canada pour fonctionner avec les types d'antenne énumérés dans le manuel d'usage et ayant un gain admissible maximal et l'impédance requise pour chaque type d'antenne. Les types d'antenne non inclus dans cette liste, ou dont le gain est supérieur au gain maximal indiqué, sont strictement interdits pour l'exploitation de l'émetteur.

### 3.3 Japan

3.3.1 *Notice for EVMs delivered in Japan:* Please see [http://www.tij.co.jp/lstds/ti\\_ja/general/eStore/notice\\_01.page](http://www.tij.co.jp/lstds/ti_ja/general/eStore/notice_01.page) 日本国内に輸入される評価用キット、ボードについては、次のところをご覧ください。  
[http://www.tij.co.jp/lstds/ti\\_ja/general/eStore/notice\\_01.page](http://www.tij.co.jp/lstds/ti_ja/general/eStore/notice_01.page)

3.3.2 *Notice for Users of EVMs Considered "Radio Frequency Products" in Japan:* EVMs entering Japan may not be certified by TI as conforming to Technical Regulations of Radio Law of Japan.

If User uses EVMs in Japan, not certified to Technical Regulations of Radio Law of Japan, User is required to follow the instructions set forth by Radio Law of Japan, which includes, but is not limited to, the instructions below with respect to EVMs (which for the avoidance of doubt are stated strictly for convenience and should be verified by User):

1. Use EVMs in a shielded room or any other test facility as defined in the notification #173 issued by Ministry of Internal Affairs and Communications on March 28, 2006, based on Sub-section 1.1 of Article 6 of the Ministry's Rule for Enforcement of Radio Law of Japan,
2. Use EVMs only after User obtains the license of Test Radio Station as provided in Radio Law of Japan with respect to EVMs, or
3. Use of EVMs only after User obtains the Technical Regulations Conformity Certification as provided in Radio Law of Japan with respect to EVMs. Also, do not transfer EVMs, unless User gives the same notice above to the transferee. Please note that if User does not follow the instructions above, User will be subject to penalties of Radio Law of Japan.

【無線電波を送信する製品の開発キットをお使いになる際の注意事項】 開発キットの中には技術基準適合証明を受けていないものがあります。技術適合証明を受けていないものご使用に際しては、電波法遵守のため、以下のいずれかの措置を取っていただく必要がありますのでご注意ください。

1. 電波法施行規則第6条第1項第1号に基づく平成18年3月28日総務省告示第173号で定められた電波暗室等の試験設備でご使用いただく。
2. 実験局の免許を取得後ご使用いただく。
3. 技術基準適合証明を取得後ご使用いただく。

なお、本製品は、上記の「ご使用にあたっての注意」を譲渡先、移転先に通知しない限り、譲渡、移転できないものとします。

上記を遵守頂けない場合は、電波法の罰則が適用される可能性があることをご留意ください。日本テキサス・インスツルメンツ株式会社  
東京都新宿区西新宿 6 丁目 2 4 番 1 号  
西新宿三井ビル

3.3.3 *Notice for EVMs for Power Line Communication:* Please see [http://www.tij.co.jp/llds/ti\\_ja/general/eStore/notice\\_02.page](http://www.tij.co.jp/llds/ti_ja/general/eStore/notice_02.page)  
電力線搬送波通信についての開発キットをお使いになる際の注意事項については、次のところをご覧ください。 [http://www.tij.co.jp/llds/ti\\_ja/general/eStore/notice\\_02.page](http://www.tij.co.jp/llds/ti_ja/general/eStore/notice_02.page)

#### 3.4 *European Union*

##### 3.4.1 *For EVMs subject to EU Directive 2014/30/EU (Electromagnetic Compatibility Directive):*

This is a class A product intended for use in environments other than domestic environments that are connected to a low-voltage power-supply network that supplies buildings used for domestic purposes. In a domestic environment this product may cause radio interference in which case the user may be required to take adequate measures.

#### 4 *EVM Use Restrictions and Warnings:*

4.1 EVMS ARE NOT FOR USE IN FUNCTIONAL SAFETY AND/OR SAFETY CRITICAL EVALUATIONS, INCLUDING BUT NOT LIMITED TO EVALUATIONS OF LIFE SUPPORT APPLICATIONS.

4.2 User must read and apply the user guide and other available documentation provided by TI regarding the EVM prior to handling or using the EVM, including without limitation any warning or restriction notices. The notices contain important safety information related to, for example, temperatures and voltages.

##### 4.3 *Safety-Related Warnings and Restrictions:*

4.3.1 User shall operate the EVM within TI's recommended specifications and environmental considerations stated in the user guide, other available documentation provided by TI, and any other applicable requirements and employ reasonable and customary safeguards. Exceeding the specified performance ratings and specifications (including but not limited to input and output voltage, current, power, and environmental ranges) for the EVM may cause personal injury or death, or property damage. If there are questions concerning performance ratings and specifications, User should contact a TI field representative prior to connecting interface electronics including input power and intended loads. Any loads applied outside of the specified output range may also result in unintended and/or inaccurate operation and/or possible permanent damage to the EVM and/or interface electronics. Please consult the EVM user guide prior to connecting any load to the EVM output. If there is uncertainty as to the load specification, please contact a TI field representative. During normal operation, even with the inputs and outputs kept within the specified allowable ranges, some circuit components may have elevated case temperatures. These components include but are not limited to linear regulators, switching transistors, pass transistors, current sense resistors, and heat sinks, which can be identified using the information in the associated documentation. When working with the EVM, please be aware that the EVM may become very warm.

4.3.2 EVMs are intended solely for use by technically qualified, professional electronics experts who are familiar with the dangers and application risks associated with handling electrical mechanical components, systems, and subsystems. User assumes all responsibility and liability for proper and safe handling and use of the EVM by User or its employees, affiliates, contractors or designees. User assumes all responsibility and liability to ensure that any interfaces (electronic and/or mechanical) between the EVM and any human body are designed with suitable isolation and means to safely limit accessible leakage currents to minimize the risk of electrical shock hazard. User assumes all responsibility and liability for any improper or unsafe handling or use of the EVM by User or its employees, affiliates, contractors or designees.

4.4 User assumes all responsibility and liability to determine whether the EVM is subject to any applicable international, federal, state, or local laws and regulations related to User's handling and use of the EVM and, if applicable, User assumes all responsibility and liability for compliance in all respects with such laws and regulations. User assumes all responsibility and liability for proper disposal and recycling of the EVM consistent with all applicable international, federal, state, and local requirements.

5. *Accuracy of Information:* To the extent TI provides information on the availability and function of EVMs, TI attempts to be as accurate as possible. However, TI does not warrant the accuracy of EVM descriptions, EVM availability or other information on its websites as accurate, complete, reliable, current, or error-free.

6. *Disclaimers:*
- 6.1 EXCEPT AS SET FORTH ABOVE, EVMS AND ANY MATERIALS PROVIDED WITH THE EVM (INCLUDING, BUT NOT LIMITED TO, REFERENCE DESIGNS AND THE DESIGN OF THE EVM ITSELF) ARE PROVIDED "AS IS" AND "WITH ALL FAULTS." TI DISCLAIMS ALL OTHER WARRANTIES, EXPRESS OR IMPLIED, REGARDING SUCH ITEMS, INCLUDING BUT NOT LIMITED TO ANY EPIDEMIC FAILURE WARRANTY OR IMPLIED WARRANTIES OF MERCHANTABILITY OR FITNESS FOR A PARTICULAR PURPOSE OR NON-INFRINGEMENT OF ANY THIRD PARTY PATENTS, COPYRIGHTS, TRADE SECRETS OR OTHER INTELLECTUAL PROPERTY RIGHTS.
- 6.2 EXCEPT FOR THE LIMITED RIGHT TO USE THE EVM SET FORTH HEREIN, NOTHING IN THESE TERMS SHALL BE CONSTRUED AS GRANTING OR CONFERRING ANY RIGHTS BY LICENSE, PATENT, OR ANY OTHER INDUSTRIAL OR INTELLECTUAL PROPERTY RIGHT OF TI, ITS SUPPLIERS/LICENSORS OR ANY OTHER THIRD PARTY, TO USE THE EVM IN ANY FINISHED END-USER OR READY-TO-USE FINAL PRODUCT, OR FOR ANY INVENTION, DISCOVERY OR IMPROVEMENT, REGARDLESS OF WHEN MADE, CONCEIVED OR ACQUIRED.
7. *USER'S INDEMNITY OBLIGATIONS AND REPRESENTATIONS.* USER WILL DEFEND, INDEMNIFY AND HOLD TI, ITS LICENSORS AND THEIR REPRESENTATIVES HARMLESS FROM AND AGAINST ANY AND ALL CLAIMS, DAMAGES, LOSSES, EXPENSES, COSTS AND LIABILITIES (COLLECTIVELY, "CLAIMS") ARISING OUT OF OR IN CONNECTION WITH ANY HANDLING OR USE OF THE EVM THAT IS NOT IN ACCORDANCE WITH THESE TERMS. THIS OBLIGATION SHALL APPLY WHETHER CLAIMS ARISE UNDER STATUTE, REGULATION, OR THE LAW OF TORT, CONTRACT OR ANY OTHER LEGAL THEORY, AND EVEN IF THE EVM FAILS TO PERFORM AS DESCRIBED OR EXPECTED.
8. *Limitations on Damages and Liability:*
- 8.1 *General Limitations.* IN NO EVENT SHALL TI BE LIABLE FOR ANY SPECIAL, COLLATERAL, INDIRECT, PUNITIVE, INCIDENTAL, CONSEQUENTIAL, OR EXEMPLARY DAMAGES IN CONNECTION WITH OR ARISING OUT OF THESE TERMS OR THE USE OF THE EVMS , REGARDLESS OF WHETHER TI HAS BEEN ADVISED OF THE POSSIBILITY OF SUCH DAMAGES. EXCLUDED DAMAGES INCLUDE, BUT ARE NOT LIMITED TO, COST OF REMOVAL OR REINSTALLATION, ANCILLARY COSTS TO THE PROCUREMENT OF SUBSTITUTE GOODS OR SERVICES, RETESTING, OUTSIDE COMPUTER TIME, LABOR COSTS, LOSS OF GOODWILL, LOSS OF PROFITS, LOSS OF SAVINGS, LOSS OF USE, LOSS OF DATA, OR BUSINESS INTERRUPTION. NO CLAIM, SUIT OR ACTION SHALL BE BROUGHT AGAINST TI MORE THAN TWELVE (12) MONTHS AFTER THE EVENT THAT GAVE RISE TO THE CAUSE OF ACTION HAS OCCURRED.
- 8.2 *Specific Limitations.* IN NO EVENT SHALL TI'S AGGREGATE LIABILITY FROM ANY USE OF AN EVM PROVIDED HEREUNDER, INCLUDING FROM ANY WARRANTY, INDEMNITY OR OTHER OBLIGATION ARISING OUT OF OR IN CONNECTION WITH THESE TERMS, , EXCEED THE TOTAL AMOUNT PAID TO TI BY USER FOR THE PARTICULAR EVM(S) AT ISSUE DURING THE PRIOR TWELVE (12) MONTHS WITH RESPECT TO WHICH LOSSES OR DAMAGES ARE CLAIMED. THE EXISTENCE OF MORE THAN ONE CLAIM SHALL NOT ENLARGE OR EXTEND THIS LIMIT.
9. *Return Policy.* Except as otherwise provided, TI does not offer any refunds, returns, or exchanges. Furthermore, no return of EVM(s) will be accepted if the package has been opened and no return of the EVM(s) will be accepted if they are damaged or otherwise not in a resalable condition. If User feels it has been incorrectly charged for the EVM(s) it ordered or that delivery violates the applicable order, User should contact TI. All refunds will be made in full within thirty (30) working days from the return of the components(s), excluding any postage or packaging costs.
10. *Governing Law:* These terms and conditions shall be governed by and interpreted in accordance with the laws of the State of Texas, without reference to conflict-of-laws principles. User agrees that non-exclusive jurisdiction for any dispute arising out of or relating to these terms and conditions lies within courts located in the State of Texas and consents to venue in Dallas County, Texas. Notwithstanding the foregoing, any judgment may be enforced in any United States or foreign court, and TI may seek injunctive relief in any United States or foreign court.

## IMPORTANT NOTICE FOR TI DESIGN INFORMATION AND RESOURCES

Texas Instruments Incorporated ("TI") technical, application or other design advice, services or information, including, but not limited to, reference designs and materials relating to evaluation modules, (collectively, "TI Resources") are intended to assist designers who are developing applications that incorporate TI products; by downloading, accessing or using any particular TI Resource in any way, you (individually or, if you are acting on behalf of a company, your company) agree to use it solely for this purpose and subject to the terms of this Notice.

TI's provision of TI Resources does not expand or otherwise alter TI's applicable published warranties or warranty disclaimers for TI products, and no additional obligations or liabilities arise from TI providing such TI Resources. TI reserves the right to make corrections, enhancements, improvements and other changes to its TI Resources.

You understand and agree that you remain responsible for using your independent analysis, evaluation and judgment in designing your applications and that you have full and exclusive responsibility to assure the safety of your applications and compliance of your applications (and of all TI products used in or for your applications) with all applicable regulations, laws and other applicable requirements. You represent that, with respect to your applications, you have all the necessary expertise to create and implement safeguards that (1) anticipate dangerous consequences of failures, (2) monitor failures and their consequences, and (3) lessen the likelihood of failures that might cause harm and take appropriate actions. You agree that prior to using or distributing any applications that include TI products, you will thoroughly test such applications and the functionality of such TI products as used in such applications. TI has not conducted any testing other than that specifically described in the published documentation for a particular TI Resource.

You are authorized to use, copy and modify any individual TI Resource only in connection with the development of applications that include the TI product(s) identified in such TI Resource. NO OTHER LICENSE, EXPRESS OR IMPLIED, BY ESTOPPEL OR OTHERWISE TO ANY OTHER TI INTELLECTUAL PROPERTY RIGHT, AND NO LICENSE TO ANY TECHNOLOGY OR INTELLECTUAL PROPERTY RIGHT OF TI OR ANY THIRD PARTY IS GRANTED HEREIN, including but not limited to any patent right, copyright, mask work right, or other intellectual property right relating to any combination, machine, or process in which TI products or services are used. Information regarding or referencing third-party products or services does not constitute a license to use such products or services, or a warranty or endorsement thereof. Use of TI Resources may require a license from a third party under the patents or other intellectual property of the third party, or a license from TI under the patents or other intellectual property of TI.

TI RESOURCES ARE PROVIDED "AS IS" AND WITH ALL FAULTS. TI DISCLAIMS ALL OTHER WARRANTIES OR REPRESENTATIONS, EXPRESS OR IMPLIED, REGARDING TI RESOURCES OR USE THEREOF, INCLUDING BUT NOT LIMITED TO ACCURACY OR COMPLETENESS, TITLE, ANY EPIDEMIC FAILURE WARRANTY AND ANY IMPLIED WARRANTIES OF MERCHANTABILITY, FITNESS FOR A PARTICULAR PURPOSE, AND NON-INFRINGEMENT OF ANY THIRD PARTY INTELLECTUAL PROPERTY RIGHTS.

TI SHALL NOT BE LIABLE FOR AND SHALL NOT DEFEND OR INDEMNIFY YOU AGAINST ANY CLAIM, INCLUDING BUT NOT LIMITED TO ANY INFRINGEMENT CLAIM THAT RELATES TO OR IS BASED ON ANY COMBINATION OF PRODUCTS EVEN IF DESCRIBED IN TI RESOURCES OR OTHERWISE. IN NO EVENT SHALL TI BE LIABLE FOR ANY ACTUAL, DIRECT, SPECIAL, COLLATERAL, INDIRECT, PUNITIVE, INCIDENTAL, CONSEQUENTIAL OR EXEMPLARY DAMAGES IN CONNECTION WITH OR ARISING OUT OF TI RESOURCES OR USE THEREOF, AND REGARDLESS OF WHETHER TI HAS BEEN ADVISED OF THE POSSIBILITY OF SUCH DAMAGES.

You agree to fully indemnify TI and its representatives against any damages, costs, losses, and/or liabilities arising out of your non-compliance with the terms and provisions of this Notice.

This Notice applies to TI Resources. Additional terms apply to the use and purchase of certain types of materials, TI products and services. These include; without limitation, TI's standard terms for semiconductor products (<http://www.ti.com/sc/docs/stdterms.htm>), [evaluation modules](#), and [samples](http://www.ti.com/sc/docs/sampterm.htm) (<http://www.ti.com/sc/docs/sampterm.htm>).

Mailing Address: Texas Instruments, Post Office Box 655303, Dallas, Texas 75265  
Copyright © 2018, Texas Instruments Incorporated