



# CODE 21 - LOW PROFILE HEAT SHRINK BOOT BACKSHELL

203M612-19B

SERIES \_\_\_\_\_  
 ORDER NUMBER (TABLE 1) \_\_\_\_\_  
 MATERIAL \_\_\_\_\_  
 REFER TO CH00-0250-004  
 FINISH \_\_\_\_\_  
 REFER TO CH00-0250-004

## NOTES:

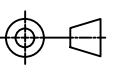
1. THIS PRODUCT IS DESIGNED TO TERMINATE A HEAT SHRINKABLE LIPPED BOOT TO A CONNECTOR.
2. FOR ADDITIONAL DIMENSIONS, ORDERING INFORMATION AND MODIFICATIONS, SEE CH00-0250-004.
3. BACKSHELL TO BE PERMANENTLY MARKED/BAGGED AND LABELLED WITH CODE IDENTIFICATION NUMBER AND PART NUMBER. (e.g. 06090-203M612-19B).
4. KNURL INSIDE BOOT GROOVE MAY BE SUPPLIED AT MANUFACTURER'S OPTION.
5. BACKSHELL MATES TO MIL-C-26482 SERIES I, CLASS E, F, MS3110, MS3111, MS3116 CONNECTORS.

DRAWN	W.RUST	DATE	14/09/2015	 3RD ANGLE PROJECTION NOT TO SCALE	<b>TITLE:</b> LOW PROFILE HEAT SHRINK BOOT BACKSHELL	 Polamco			
CHECKED		14/09/2015	UNLESS OTHERWISE SPECIFIED ALL DIMENSIONS IN MILLIMETRES GENERAL TOL LINEAR +/-0,25MM ANGULAR +/- 1°				<b>ASSY USED ON:</b> MIL-DTL-26482 SERIES I	 TE	
APPROVED	K.SHEPPARD	09/10/2015		<b>REVISIONS</b>					TE CONNECTIVITY - POLAMCO LTD RESERVES THE RIGHT TO AMEND THIS DRAWING AND THE INFORMATION SET FORTH HEREON AT ANY TIME. USERS SHOULD INDEPENDENTLY EVALUATE THE SUITABILITY OF THE PRODUCT FOR THEIR APPLICATION.
APPROVED	H.SMITH	14/10/2015	LTR	DESCRIPTION	DATE	APPROVED	DRAWING NO:	DRAWING REV:	
			G	REVISED PER ECO-15-002747	19/02/15	H.SMITH	203M6XX	H	1
			H	REVISED PER ECO-15-013980	14/10/2015	H.SMITH			
TE CAGE CODE: 06090 POLAMCO/TE CAGE CODE: U5792									

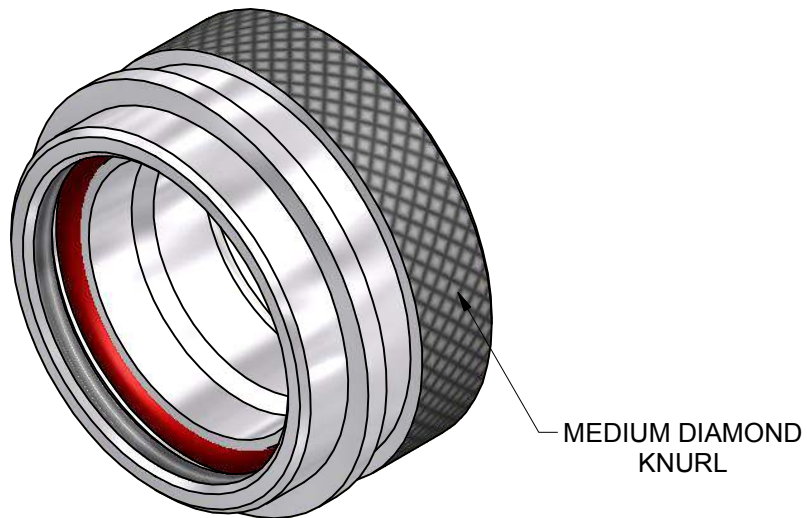

A-A

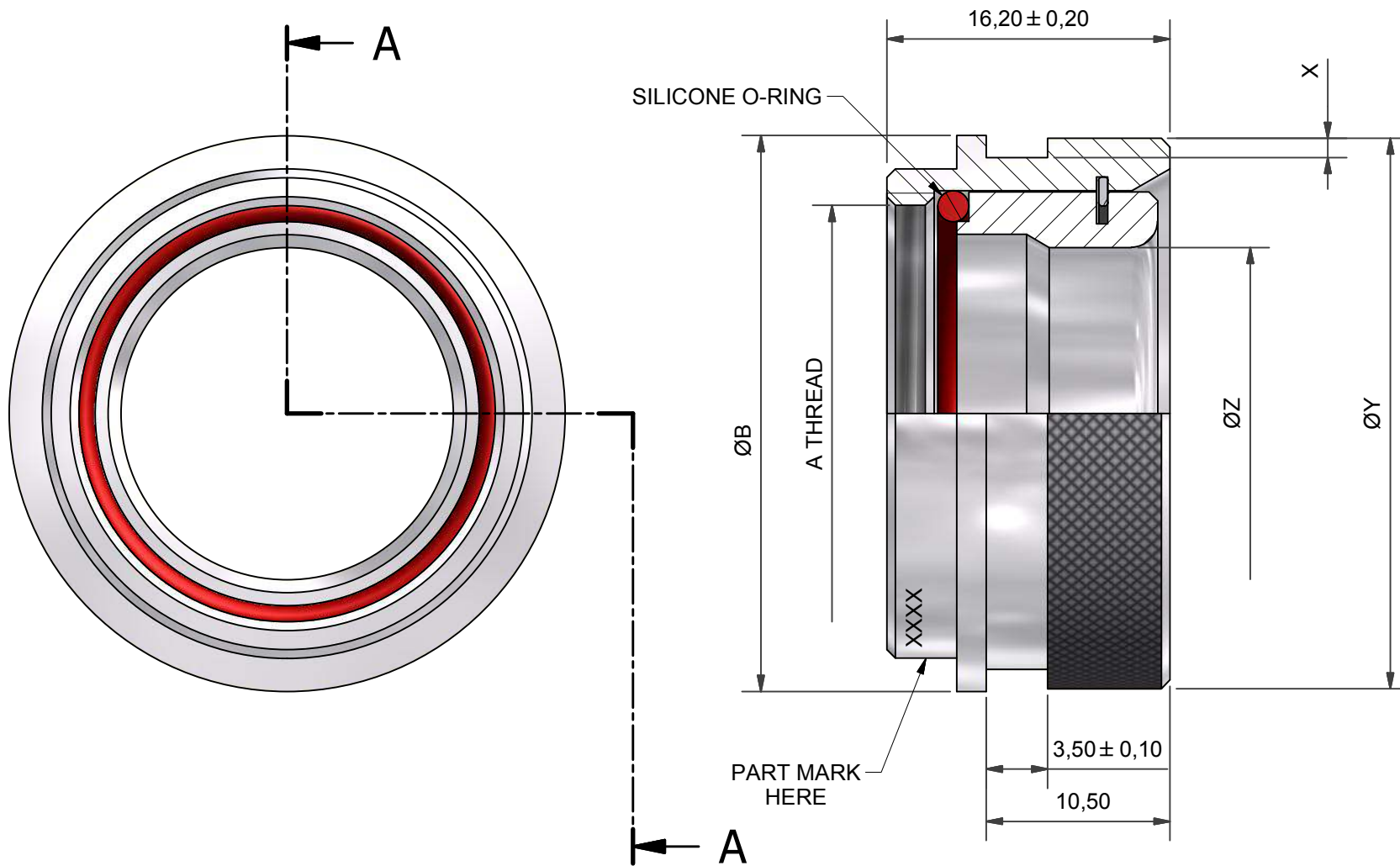

TABLE 1

PART NUMBER	SHELL SIZE (5)	A THREAD	ØB MAX	X +0,2/-0	ØY +0,00/-0,40	ØZ MIN
203M608	8	7/16-28UNEF	19,1	1,1	17,5	7,0
203M610	10	9/16-24UNEF	22,3	1,1	20,7	9,7
203M612	12	11/16-24UNEF	25,4	1,1	23,9	13,4
203M614	14	13/16-20UNEF	28,6	1,1	27,0	15,8
203M616	16	15/16-20UNEF	31,8	1,1	31,5	18,9
203M618	18	1 1/16-18UNEF	35,0	1,1	33,5	21,3
203M620	20	1 3/16-18UNEF	38,1	1,7	36,5	24,5
203M622	22	1 5/16-18UNEF	41,3	1,7	39,8	27,7
203M624	24	1 7/16-18UNEF	44,5	1,7	43,0	30,9

DRAWN	W.RUST	DATE	14/09/2015	<p>3RD ANGLE PROJECTION NOT TO SCALE</p> <p>UNLESS OTHERWISE SPECIFIED ALL DIMENSIONS IN MILLIMETRES GENERAL TOL LINEAR +/-0,25MM ANGULAR +/- 1°</p>
CHECKED		DATE	14/09/2015	
APPROVED	K.SHEPPARD	DATE	09/10/2015	
APPROVED	H.SMITH	DATE	14/10/2015	
REVISIONS				
LTR	DESCRIPTION	DATE	APPROVED	
G	REVISED PER ECO-15-002747	19/02/15	H.SMITH	
H	REVISED PER ECO-15-013980	14/10/2015	H.SMITH	
TE CAGE CODE: 06090 POLAMCO/TE CAGE CODE: U5792				

TITLE:	LOW PROFILE HEAT SHRINK BOOT BACKSHELL		
ASSY USED ON:	MIL-DTL-26482 SERIES I		
TE CONNECTIVITY - POLAMCO LTD RESERVES THE RIGHT TO AMEND THIS DRAWING AND THE INFORMATION SET FORTH HEREON AT ANY TIME. USERS SHOULD INDEPENDENTLY EVALUATE THE SUITABILITY OF THE PRODUCT FOR THEIR APPLICATION.			
DRAWING NO:	203M6XX	DRAWING REV:	H
SHT	2		

