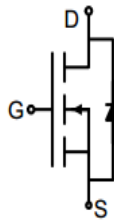
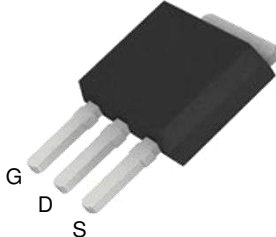

## N-Channel Enhancement Mode Power MOSFET

<p><b>Description</b></p> <p>The G50N03J uses advanced trench technology to provide excellent <math>R_{DS(ON)}</math>, low gate charge. It can be used in a wide variety of applications.</p> <p><b>General Features</b></p> <ul style="list-style-type: none"> <li>● <math>V_{DS}</math> 30V</li> <li>● <math>I_D</math> (at <math>V_{GS} = 10V</math>) 65A</li> <li>● <math>R_{DS(ON)}</math> (at <math>V_{GS} = 10V</math>) &lt; 7m<math>\Omega</math></li> <li>● <math>R_{DS(ON)}</math> (at <math>V_{GS} = 4.5V</math>) &lt; 12m<math>\Omega</math></li> <li>● 100% Avalanche Tested</li> <li>● RoHS Compliant</li> </ul> <p><b>Application</b></p> <ul style="list-style-type: none"> <li>● Power switch</li> <li>● DC/DC converters</li> </ul>		 <p>Schematic diagram</p>  <p>TO-251</p>	
<b>Device</b>	<b>Package</b>	<b>Marking</b>	<b>Packaging</b>
G50N03J	TO-251	G50N03	75pcs/Tube

<b>Absolute Maximum Ratings</b> $T_C = 25^{\circ}C$ , unless otherwise noted			
Parameter	Symbol	Value	Unit
Drain-Source Voltage	$V_{DS}$	30	V
Continuous Drain Current	$I_D$	65	A
Pulsed Drain Current (note1)	$I_{DM}$	260	A
Gate-Source Voltage	$V_{GS}$	$\pm 20$	V
Power Dissipation	$P_D$	48	W
Single pulse avalanche energy (note3)	$E_{AS}$	43	mJ
Operating Junction and Storage Temperature Range	$T_J, T_{stg}$	-55 To 150	$^{\circ}C$
<b>Thermal Resistance</b>			
Parameter	Symbol	Value	Unit
Thermal Resistance, Junction-to-Case	$R_{thJC}$	2.59	$^{\circ}C/W$

Specifications $T_J = 25^\circ\text{C}$ , unless otherwise noted						
Parameter	Symbol	Test Conditions	Value			Unit
			Min.	Typ.	Max.	
<b>Static Parameters</b>						
Drain-Source Breakdown Voltage	$V_{(BR)DSS}$	$V_{GS} = 0V, I_D = 250\mu A$	30	--	--	V
Zero Gate Voltage Drain Current	$I_{DSS}$	$V_{DS} = 30V, V_{GS} = 0V$	--	--	1	$\mu A$
Gate-Source Leakage	$I_{GSS}$	$V_{GS} = \pm 20V$	--	--	$\pm 100$	nA
Gate-Source Threshold Voltage	$V_{GS(th)}$	$V_{DS} = V_{GS}, I_D = 250\mu A$	1	1.45	2.5	V
Drain-Source On-Resistance	$R_{DS(on)}$	$V_{GS} = 10V, I_D = 20A$	--	5.0	7	m $\Omega$
		$V_{GS} = 4.5V, I_D = 15A$	--	7.2	12	
Forward Transconductance	$g_{FS}$	$V_{DS}=5V, I_D=20A$	--	33	--	S
<b>Dynamic Parameters</b>						
Input Capacitance	$C_{iss}$	$V_{GS} = 0V,$ $V_{DS} = 15V,$ $f = 1.0MHz$	--	1255	--	pF
Output Capacitance	$C_{oss}$		--	232	--	
Reverse Transfer Capacitance	$C_{rss}$		--	185	--	
Total Gate Charge	$Q_g$	$V_{DD} = 10V,$ $I_D = 20A,$ $V_{GS} = 10V$	--	16.6	--	nC
Gate-Source Charge	$Q_{gs}$		--	3.6	--	
Gate-Drain Charge	$Q_{gd}$		--	3	--	
Turn-on Delay Time	$t_{d(on)}$	$V_{DD} = 15V,$ $I_D = 20A,$ $R_G = 1.8\Omega$	--	10	--	ns
Turn-on Rise Time	$t_r$		--	8	--	
Turn-off Delay Time	$t_{d(off)}$		--	30	--	
Turn-off Fall Time	$t_f$		--	5	--	
<b>Drain-Source Body Diode Characteristics</b>						
Continuous Body Diode Current	$I_S$	$T_C = 25^\circ\text{C}$	--	--	65	A
Body Diode Voltage	$V_{SD}$	$T_J = 25^\circ\text{C}, I_{SD} = 30A, V_{GS} = 0V$	--	--	1.2	V

**Notes**

1. Repetitive Rating: Pulse width limited by maximum junction temperature
2. Identical low side and high side switch with identical  $R_G$
3. EAS condition :  $T_J=25^\circ\text{C}$  ,  $V_{DD}=30V, V_{GS}=10V, L=0.5mH, R_g=25\Omega$

Gate Charge Test Circuit

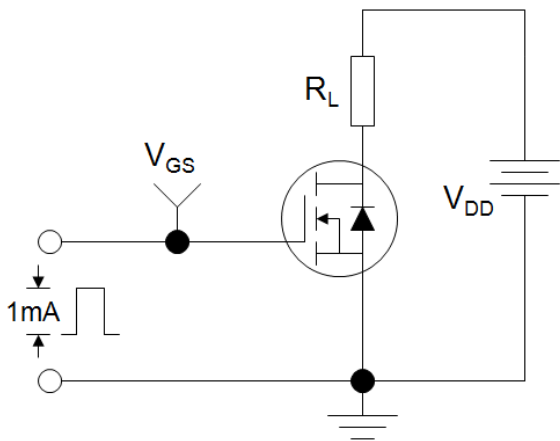

Switch Time Test Circuit

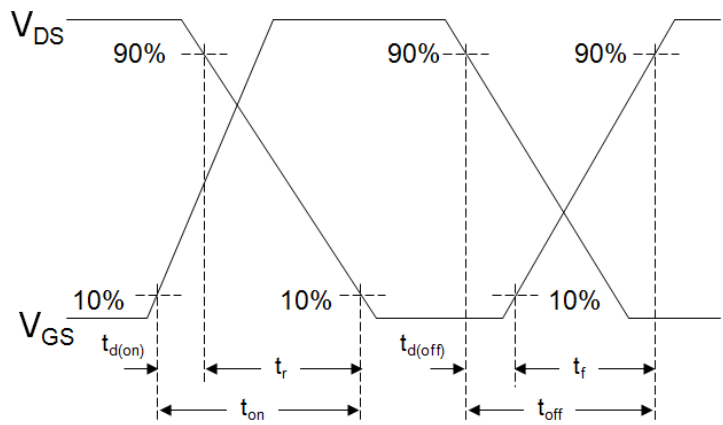
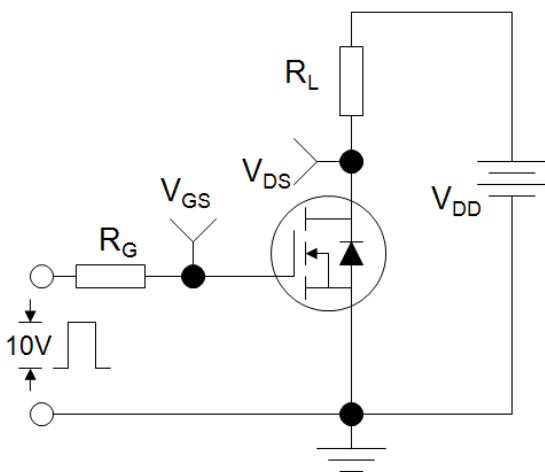

EAS Test Circuit

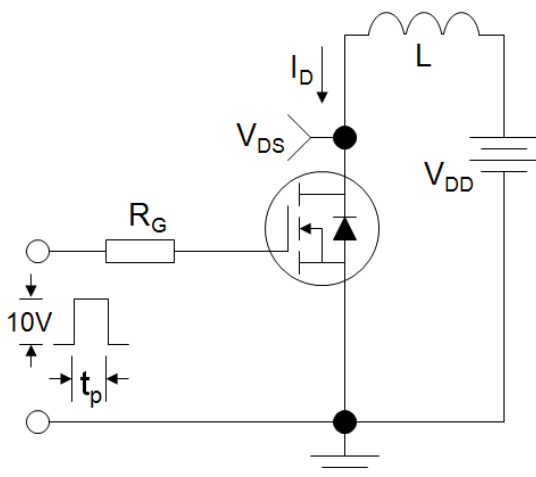

Typical Characteristics  $T_J = 25^\circ\text{C}$ , unless otherwise noted

Figure 1. Output Characteristics

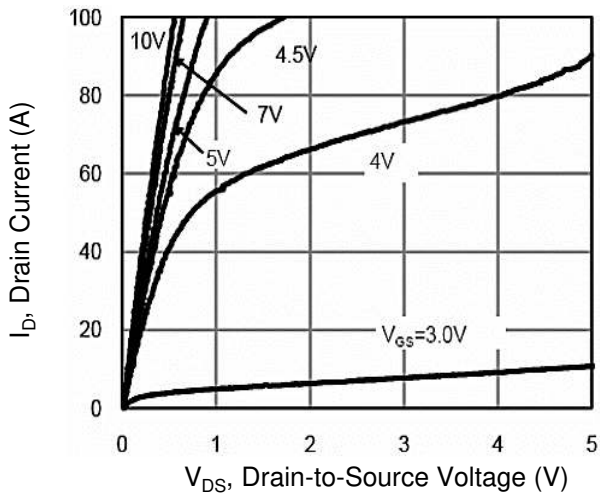

Figure 2. Transfer Characteristics

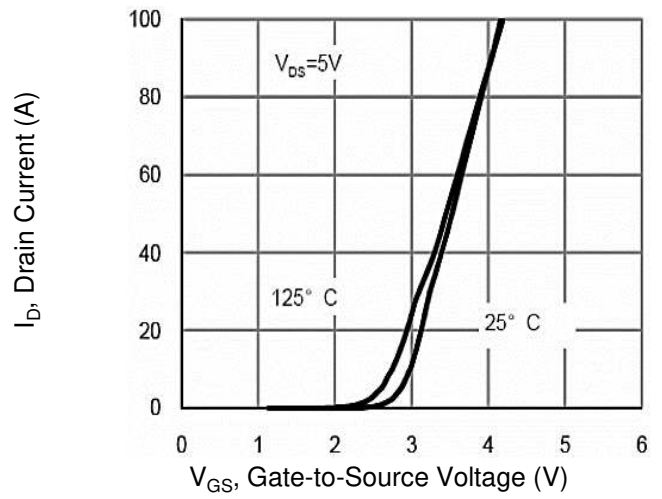

Figure 3. Gate Charge

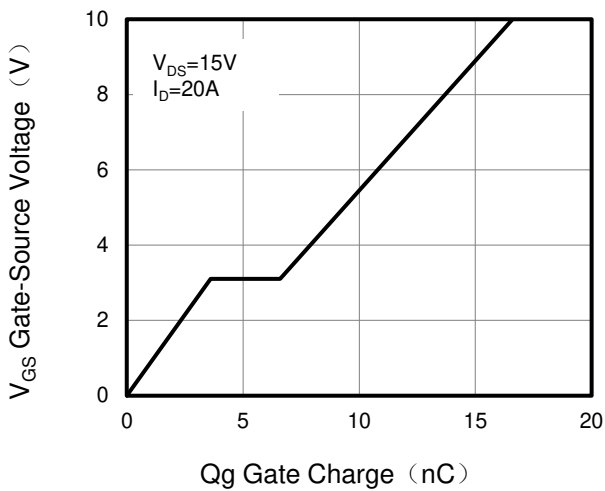

Figure 4. Drain Source On Resistance

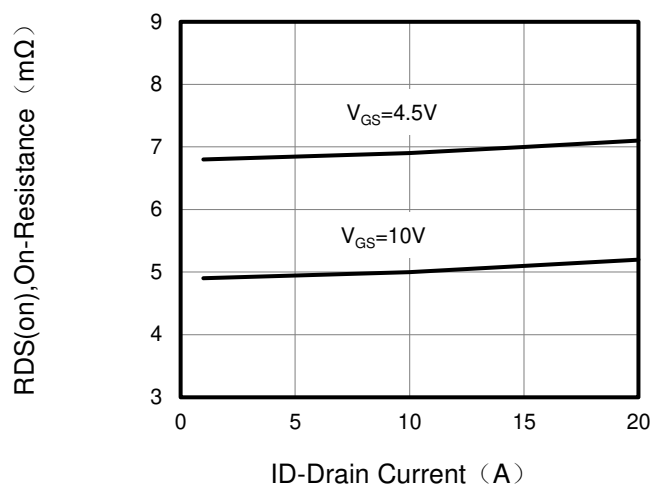

Figure 5. Capacitance

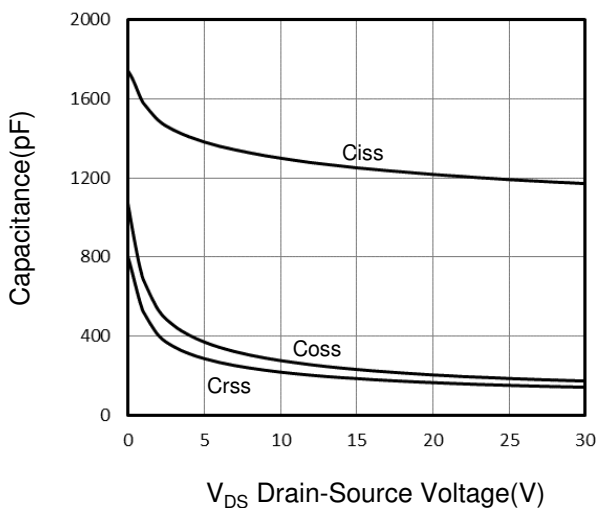
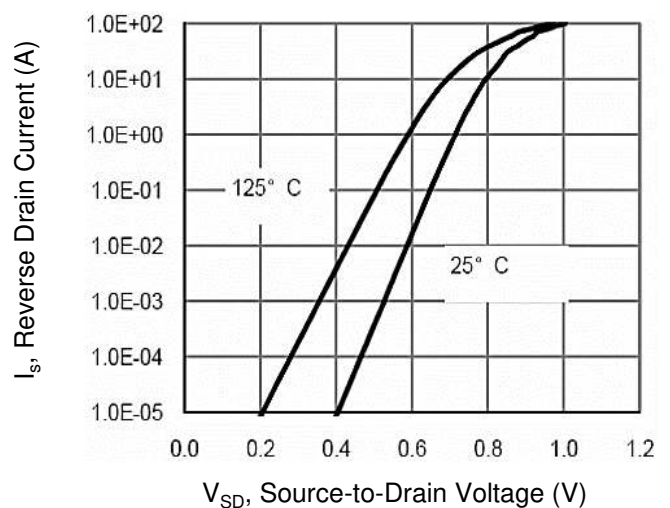

Figure 6. Source-Drain Diode Forward



Typical Characteristics  $T_J = 25^\circ\text{C}$ , unless otherwise noted

Figure 7. Drain-Source On-Resistance

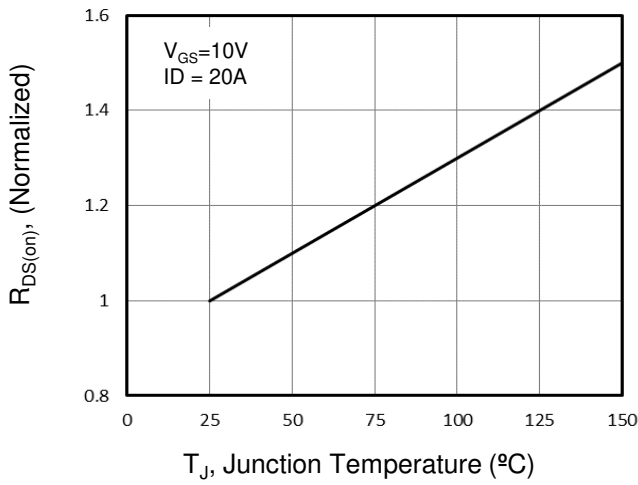

Figure 8. Safe Operation Area

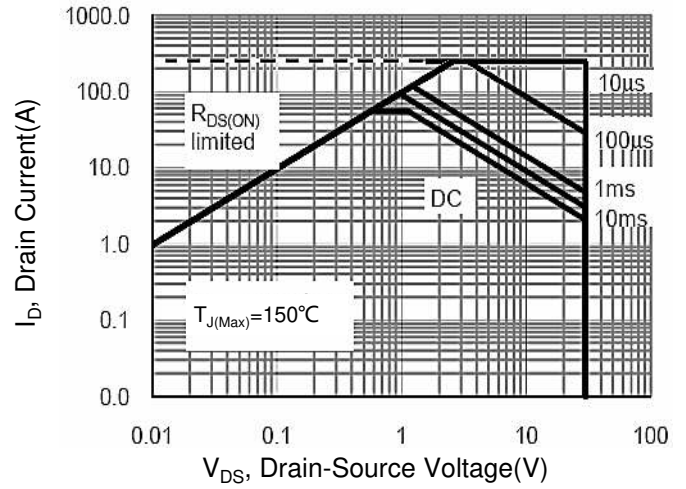
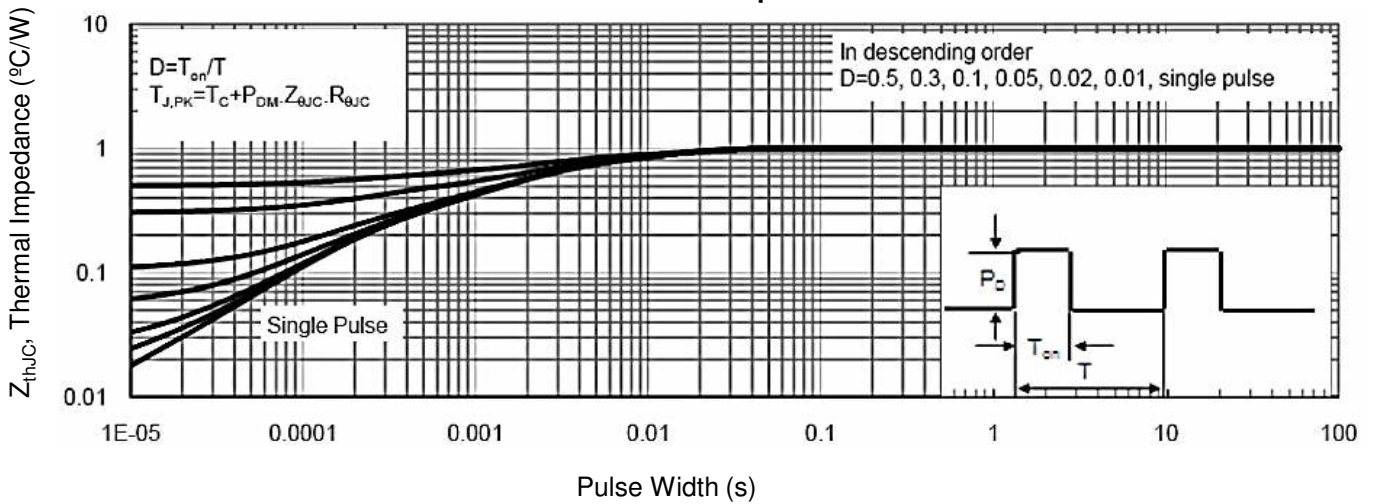
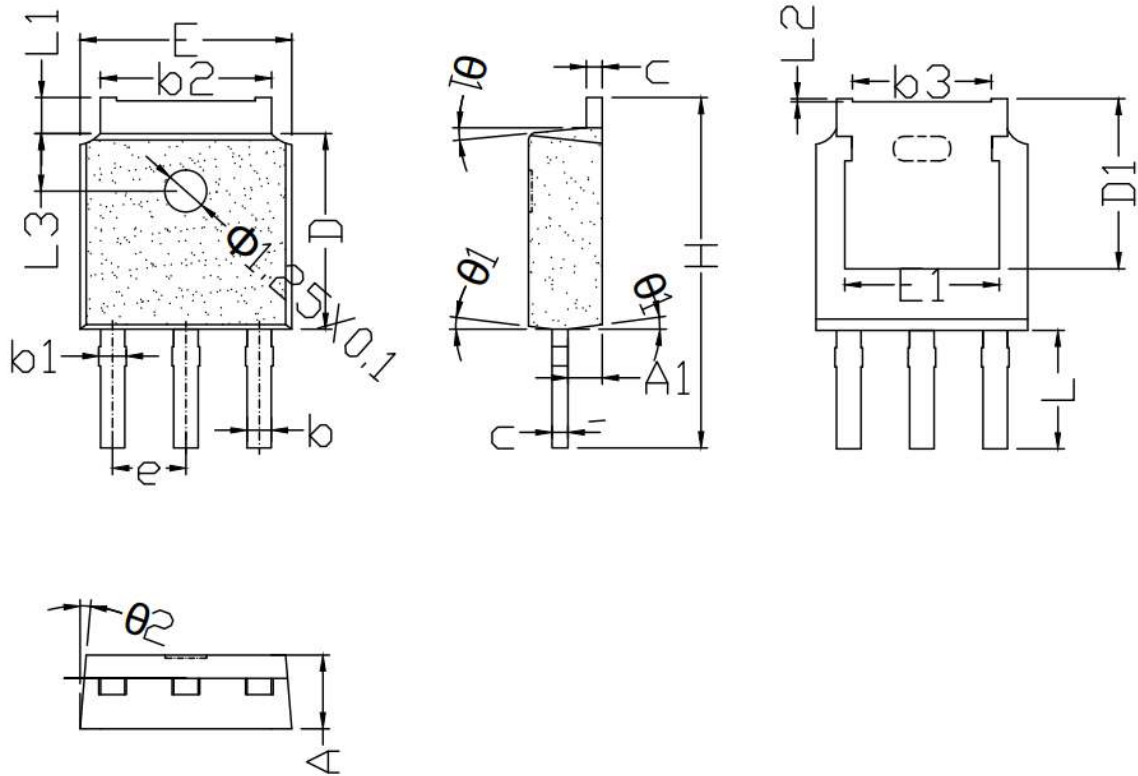

Figure 9. Normalized Maximum Transient Thermal Impedance



TO-251 Package information



COMMON DIMENSIONS

SYMBOL	mm		
	MIN	NOM	MAX
*A	2.20	2.30	2.38
*A1	0.90	1.00	1.10
*b	0.72	0.78	0.85
*b1	0.78	0.85	0.90
b2	5.23	5.33	5.46
b3	4.27	4.32	4.37
*c	0.47	0.52	0.55
*D	6.00	6.10	6.20
D1	5.40REF		
*E	6.50	6.60	6.70
E1	4.70	4.83	4.92
*e	2.286BSC		
*H	9.90	10.10	10.20
*L	3.60	3.70	3.80
L1	0.90	—	1.20
L2	0.02	0.04	0.08
L3	1.70	1.80	1.90
01	±	F°	9°
02	±	F°	9°