

MATERIAL

Transparent polyamide based (PA-T) technopolymer. Highly resistant to shocks, solvents, oils with additives, aliphatic and aromatic hydrocarbons, petrol, naphtha, phosphoric esters.
Avoid contact with alcohol or detergents containing alcohol.

SCREWS, NUTS AND WASHERS

Zinc-plated steel.

PACKING RINGS

Step-shaped for the seal on the reservoir walls and NBR synthetic rubber O-ring screw underhead.
Suggested roughness of the packing ring application surface Ra = 3 µm.

FLOAT

Glass-fibre reinforced polyamide based (PA) technopolymer, black colour, with a built-in magnetic element to activate the electric contact when the float reaches the contact threshold indicated in the drawing (data referred to mineral oil type CB68, according to ISO 3498, temperature 23°C).
Floating is ensured by fluids with densities higher than 800 kg/m³.

BRACKET WITH LEVEL SENSOR AND TEMPERATURE PROBE

Watertight in glass-fibre reinforced polyamide based (PA) technopolymer, black colour, with a built-in relay (reed) with two conductors and a temperature electrical probe, made out of a platinum resistor whose ohmic resistance changes according to the temperature.
For a correct assembly see Warnings (on page 1789).

SWIVELLING CONNECTOR

With built-in cable gland and contact holder. Front or axial output (high or low) ensuring protection against water sprays (protection class IP 65 according to table EN 60529 on page A-18).

CONTRAST SCREEN

White lacquered aluminium. The housing, in the appropriate external rear slot, guarantees the best protection from direct contact with fluid. It can be taken out from the inclined side, before assembly to allow the insertion of level lines or words.

STANDARD EXECUTIONS

- **HCV-E-STL-NO**: with electric contact normally open (NO).
- **HCV-E-STL-NC**: with electric contact normally closed (NC).

MAXIMUM CONTINUOUS WORKING TEMPERATURE

90°C (with oil).

FEATURES AND PERFORMANCES

In addition to the visual control, HCV-E-STL column level indicator generates an electric signal when the oil level drops to a minimum and an analogic electric signal of the oil temperature.
Ultrasound welding to guarantee a perfect seal.
Thanks to the side output of the connector, HCV-E-STL level indicator allows to minimise the level of intervention of the sensor.
Maximum fluid level visibility even from side positions.
Lens effect for a better visibility of the fluid level.

TECHNICAL DATA

In laboratory tests carried out with mineral oil type CB68 (according to ISO 3498) at 23°C for a limited period of time, the weld stood up to: 18 bar (HCV.76), 18 bar (HCV.127) and 12 bar (HCV.254).
For use with other fluids and under different pressure and temperature conditions, please contact ELESA Technical Department.
In any case we suggest to verify the suitability of the product under the actual working conditions.

SPECIAL EXECUTIONS ON REQUEST

- Level indicators with stainless steel screws, nuts and washers.
- Level indicators HCV.76 with screws M12.
- Level indicators for use with fluids containing alcohol.
- UV resistant transparent technopolymer indicators.



ELESA Original design

FUNCTIONING OF THE TEMPERATURE ELECTRICAL PROBE

The working principle of the temperature probe is to measure the variation of resistance of a platinum element: 100 ohm = 0°C, 138.4 ohm = 100°C. The function between temperature (T) and resistance (R) is approximately linear over a small temperature range: for example, if you assume that it is linear over the 0° to 100°C range, the error at 50°C is 0.4°C.
For precision measurement, it is necessary to linearise the resistance to give an accurate temperature. The most recent definition of the function between resistance and temperature is International Temperature Standard 90 (ITS-90). The function between resistance and temperature, obtained in laboratory tests, measuring directly the resistance value on the contacts is shown in the graph. We suggest, anyway, to set the system in order to compensate both heat dissipation and cable resistance. A 1°C temperature change will cause a 0.384 ohm change in resistance, so even a small error in measurement of the resistance (for example, the resistance of the wires leading to the sensor) can cause a large error in the measurement of the temperature.
Because of the low signal levels, it is important to keep any cables away from electric cables, motors, switchgear and other devices that may emit magnetic or electrical noise. Using screened cable, with the screen grounded at one end, may help to reduce interference.
When using long cables, it is necessary to check that the measuring equipment is able to handle the cable resistance.

Electrical features	Temperature probe
Power supply	AC/DC
Maximum current	1mA
Cable gland	Pg 7 (for cables in sheath with Ø 6 or 7 mm)
Conductors cross-section	Max. 1.5 mm²
Do not mount this indicator in proximity to magnetic fields.	

FUNCTIONING OF THE MIN LEVEL ELECTRICAL SENSOR

- HCV-E-STL-NO: the electrical contact closes on reaching the minimum level.
- HCV-E-STL-NC: the electrical contact is opened when it reaches the minimum level.

Electrical features	MIN level sensor
Power supply	AC/DC
Electric contacts	NO normally open NC normally closed
Maximum applicable voltage	NO: 140 Vac, 200 Vdc NC: 140Vac, 150 Vdc
Maximum switching current	1 A
Maximum current	NO: 1.2A NC: 2A
Maximum commutable power	NO: 10 Va NC: 20 Va
Cable gland	Pg 7 (for cables in sheath with Ø 6 or 7 mm)
Conductors cross-section	Max. 1.5 mm ²
Do not mount this indicator in proximity to magnetic fields.	

Resistance / temperature conversion graph

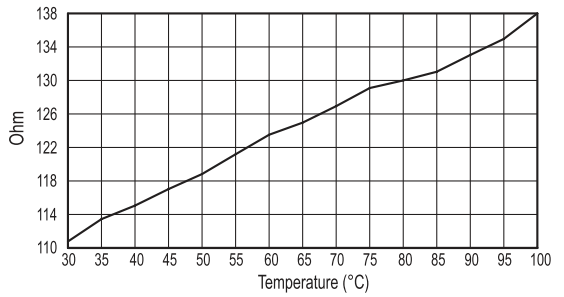

CONNECTOR ASSEMBLY INSTRUCTIONS

1. Remove the connector from the indicator by unscrewing the set screw placed on the connector, take the contact holders out and loosen the cable gland.
2. Slip on the cable into the connector (standard connector) and connect the wires to the terminals 1 and 2 for the functioning of the MIN level sensor, to the terminals 3 and earth for the functioning of the temperature probe.
3. Assemble by pressing the contact holder into the connector in the required position.
4. Screw the connectors to the indicator and then tighten the cable glands.

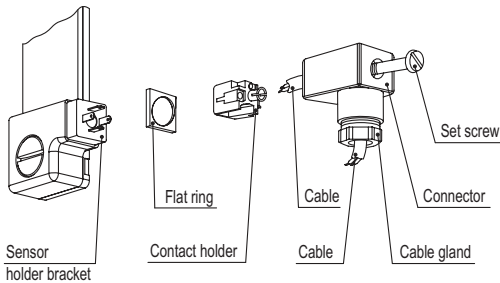
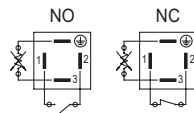

Conversion Table	
1 mm = 0.039 inch	
mm	inch
76	2.99
127	5.00
254	10.00

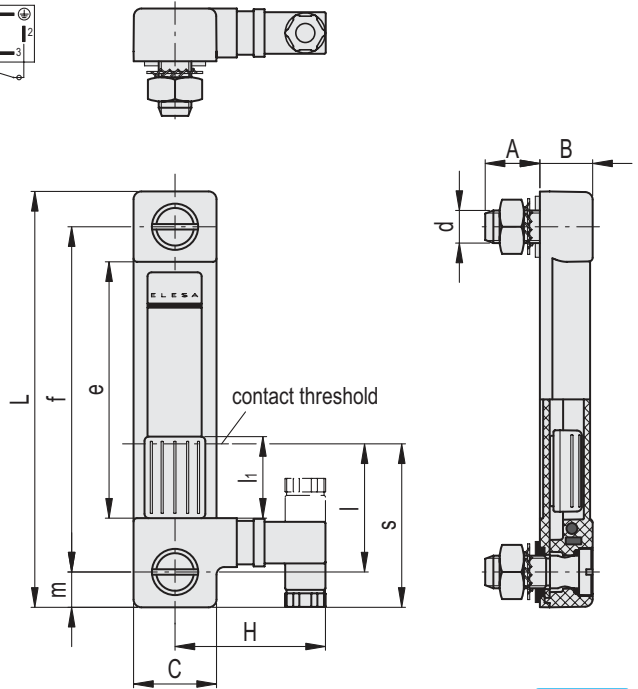
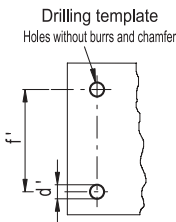

METRIC

Code	Description	f	d	A	B	C	H	L	e	l	lt	m	s	d ^{-0.2}	f _{±0.2}	C# [Nm]	⚙️
11056	HCV.76-E-STL-NO-M10	76	M10	20	19.5	30.5	55	102	43.5	40	20	13	53	10.5	76	12	133
11057	HCV.76-E-STL-NC-M10	76	M10	20	19.5	30.5	55	102	43.5	40	20	13	53	10.5	76	12	133
11117	HCV.127-E-STL-NO-M12	127	M12	20	19.5	30.5	55	153	97	50	30	13	63	12.5	127	12	153
11118	HCV.127-E-STL-NC-M12	127	M12	20	19.5	30.5	55	153	97	50	30	13	63	12.5	127	12	153
11127	HCV.254-E-STL-NO-M12	254	M12	20	19.5	30.5	55	280	224	50	30	13	63	12.5	254	12	180
11128	HCV.254-E-STL-NC-M12	254	M12	20	19.5	30.5	55	280	224	50	30	13	63	12.5	254	12	180

Maximum tightening torque.

