



GWS250 Series

Single Output 250W Power Supplies

- Standby Power Draw < 0.5 Watt
- High Efficiency up to 93%
- Built to meet ErP
- 41 mm height (1U compatible)
- Convection Cooled
- 5V / 300mA Aux Supply
- Output Remote Programming
- Class C Harmonics (IEC 61000-3-2) above 25% Load
- Allows Use in Lighting Equipment
- Five Year Warranty

Key Market Segments & Applications

Targets all ErP compliant applications
 Industrial, Traffic Controls, Automated Service, Kiosks
 Test & Measurement, Entertainment Systems,
 Communications & Broadcasting, LED Displays & Signage

GWS250 Features and Benefits

Features

- Convection Cooling
- Programmable Output Voltage
- Peak Power Capability 120% (24 & 36V models)
- Average Active Efficiency @ 230V : 92.7%

Benefits

- Easier System Integration, No Audible Noise
- Broad Range of Applications
- Lower Cost, Smaller Size
- Easier System Cooling, Less Energy Used, High Reliability

Specifications

ITEMS	MODEL	GWS250
AC Input Voltage	VAC	85 - 264VAC (300VAC for 5s)
Input Frequency	Hz	47 - 63Hz
DC Input Voltage	VDC	120 - 373VDC
Inrush Current (cold start)	A	20A at 115VAC, 40A at 230VAC
Power Factor (1)	-	Meets EN61000-3-2 (Typical PF 0.98/0.95) ClassA, Class C> 25% Load
Input Current (1)	A	3.0 / 1.4
Temperature Coefficient	°C	<0.02%/°C
Overcurrent Protection	-	>105% rated output power or >101% of peak output power
Overvoltage Protection (2)	V	12V: 13.8 - 16.2V, 24V: 30.3 - 35.5V, 36V: 41.4 - 48.6V, 48V: 60 - 69.6V
Overtemperature Protection (2)	-	Yes
Hold Up Time (1)	ms	16ms
Leakage Current (Typ)	mA	0.75mA@230VAC
Remote Sense	-	No
Remote On/Off	-	Active Low
Standby Input Power (3)	W	<0.5W
Aux Supply	-	5V/0.3A
Monitoring Signal	-	DC OK, open collector signal, High on Fail (Active Low)
LED Indicator	-	Green LED = On
Output Remote Programming	-	See installation manual for details
Operating Temperature	°C	-25°C to +70°C. (Refer to Output Derating Curve) Guaranteed Start Up at -40°C
Storage Temperature	°C	-30°C to +85°C
Operating Humidity	-	30 - 90% RH (non condensing)
Storage Humidity	-	10 - 95% RH (non condensing)
Cooling	-	Convection
Withstand Voltage	-	Input to FG 1.5kVAC (20mA), Input to Output 3kVAC (20mA), output to FG 500VAC (100mA) for 1 min
Isolation Resistance	Ω	>100MΩ at 25°C & 70%RH
Vibration (non operating)	-	10 - 55Hz: 19.6m/s ² Constant sweep 1 min X, Y, Z for 1 hour each
Shock (in package)	-	< 196.1 m/s ² (20G)
Immunity	-	Built to meet EN61000-4-2 (Level 2,3), -3 (Level 3), -4 (Level 3), -5 (Level 4), -6 (Level 3), -8 (Level 4), -11
Safety Agency Approvals	-	IEC/EN/UL/CSA 60950-1 and IEC/EN/UL/CSA 62368-1, CE Mark
Conducted & Radiated EMI	-	EN55032-B, CISPR22-B
Weight (Typ)	g	850
Size (L x W x H)	mm	198 x 105 x 41
Warranty	yrs	5

Notes: (1) 115 / 230VAC input (2) Recycle AC, or use remote on/off to reset (3) When remote off and 5V Aux supply @ no load

Model Selector

Model	Voltage (V)	Adjust Range (V)	Max Current (A)	Peak Current ⁽¹⁾ DC (A)	Load Reg. (mV)	Line Reg. (mV)	Ripple Noise (mV)	Efficiency (typ) % (230VAC)
GWS250-12	12V	10.8 - 13.2	21	-	96	48	120	92
GWS250-24	24V	22 - 28.8	10.5	12.5	192	96	150	92
GWS250-36	36V	32 - 40	7	8.4	288	144	200	93
GWS250-48	48V	42 - 57.6	5.3	-	384	192	250	93

Notes: (1) Peak current 10seconds max. 35% duty cycle max.

Outline Drawing GWS250

Technical drawing of the GWS250 power supply. The drawing includes a front view showing the input terminals (AC(N), AC(L), +V, -V, FG), output terminals (+V, -V), and a signal connector (CN1). Dimensions are provided in millimeters. Key features include an output voltage adjustment potentiometer, a DC ON indicator, and a cover. A nameplate is shown with the model name, input/output specifications, and safety symbols. A signal connector pin assignment table and a matching housings table are also included.

SIGNAL CONNECTOR INFORMATION

CN1 PIN ASSIGN

1.	DCOK
2.	COM
3.	5VSB
4.	COM
5.	CNT+
6.	CNT-
7.	5V
8.	COM

SIGNAL CONNECTOR USED

PART DESCRIPTION	PART NAME	MANUFACT
PIN HEADER	S8B-PHDS(LF)(SN) (CN1)	JST

MATCHING HOUSINGS, PIN & TOOL

PART DESCRIPTION	PART NAME	MANUFACT
SOCKET HOUSING	PHDR-8VS (CN1)	JST
TERMINAL PINS	SPHD-002T-P0.5 OR SPHD-001T-P0.5	JST
HAND CRIMPING TOOL	YRS-620(SPHD-002T-P0.5) YC-610R(SPHD-001T-P0.5)	JST

==ACCESSORIES==

* SHORT PIECE -----1
SHORTING CNT+ -->CNT-
(ATTACHED ON CN1 AT SHIPMENT)

NAME PLATE

SEE NOTE A

(unit : mm)

MODEL GWS250

TDK-Lambda

PA589-02-01B

NOTES: A. Model name, input voltage range, Nominal output voltage, Maximum output current & country of manufacture are shown in accordance with the specification.
B. M4 tapped, embossed & countersunk holes (8) for customer chassis mounting. Screws must not protrude into power supply by more than 5mm

Output Derating Curve GWS250

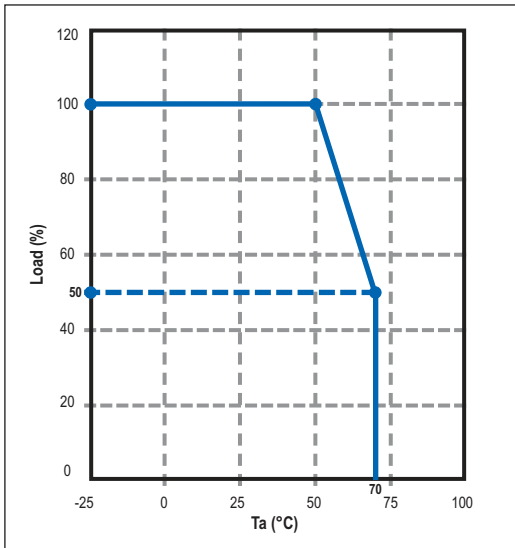

Options

Suffix	Description
/T	OTP auto recovery after unit cools down
/RL	Remote ON/OFF reverse logic (Active High)
/BAT	Battery charging for 24V (21 -29V/8.8A) & 48V (42-58V/4.4A) only
/P	Power up to 350W with system airflow of 20cfm minimum and air blowing in from opposite side of input/output connectors
/L	Without cover

Notes: GWS250-XX/YYYYYYYYYYYY where **XX** can be 12, 24, 36, or 48
Y option can be any combination of P, L, RL, CO, CO2, T, BAT, or blank

MOQs apply to Option models

Please contact your local TDK-Lambda sales office for details.

Mounting Options GWS250 - For other mounting versions please refer to Instruction Manual

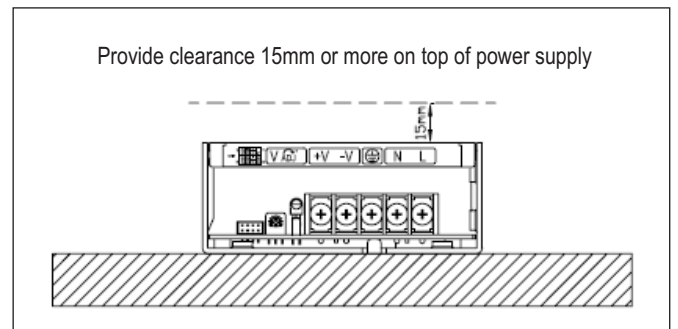
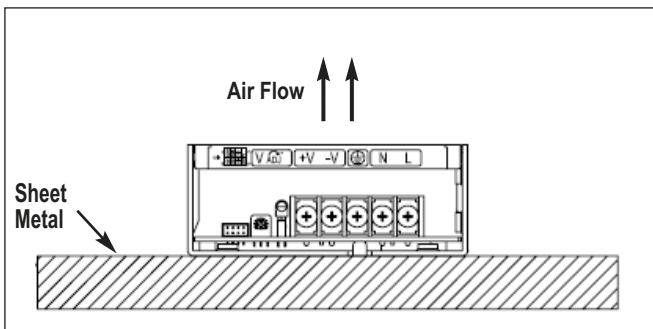

Mounting Method

- 1 This is convection cooling type power supply. In consideration of the heat radiation and safety, please keep a distance of more than 15mm between the power supply and the peripheral parts. When lining up multiple units, please make sure to place them 5mm or more apart from each other
- 2 Maximum allowable penetration of mounting screws into the power-supply is 5mm
- 3 Recommended torque for mounting screws (M4): 1.27 Nm (13.0 kgf.cm)

GWS250 Output Voltage External Control (PV)

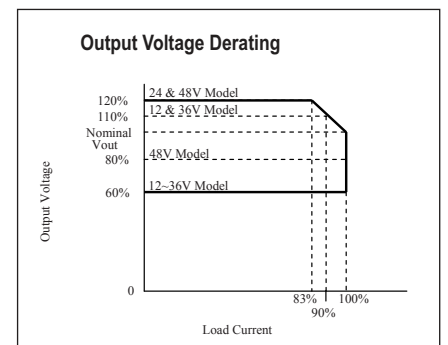
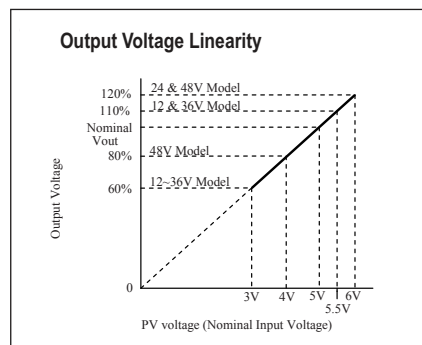
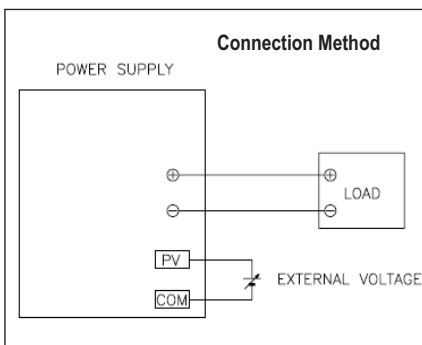

Output voltage external control function is available. Output voltage can be varied by applying an external voltage (3-6V) to 'PV' and 'COM' terminals at signal connector CN1

Please consider the following characteristics.

Notes:

- For 12V & 36V output model, limit output voltage variation range at 60% - 110%. At PV voltage variation 3V - 5.5V
- For 24V output model, limit output voltage variation range at 60% - 120%. At PV voltage variation 3V - 6V
- For 48V output model, limit output voltage variation range at 80% - 120%. At PV voltage variation 4V - 6V



TDK-Lambda France SAS

Tel: +33 1 60 12 71 65
tlf.fr.powersolutions@tdk.com
www.emea.lambda.tdk.com/fr



Italy Sales Office

Tel: +39 02 61 29 38 63
tlf.it.powersolutions@tdk.com
www.emea.lambda.tdk.com/it



Netherlands

tlf.nl.powersolutions@tdk.com
www.emea.lambda.tdk.com/nl



TDK-Lambda Germany GmbH

Tel: +49 7841 666 0
tlg.powersolutions@tdk.com
www.emea.lambda.tdk.com/de



Austria Sales Office

Tel: +43 2256 655 84
tlg.at.powersolutions@tdk.com
www.emea.lambda.tdk.com/at



Switzerland Sales Office

Tel: +41 44 850 53 53
tlg.ch.powersolutions@tdk.com
www.emea.lambda.tdk.com/ch



Nordic Sales Office

Tel: +45 8853 8086
tlg.dk.powersolutions@tdk.com
www.emea.lambda.tdk.com/dk



TDK-Lambda UK Ltd.

Tel: +44 (0) 12 71 85 66 66
tlu.powersolutions@tdk.com
www.emea.lambda.tdk.com/uk



TDK-Lambda Ltd.

Tel: +9 723 902 4333
tli.powersolutions@tdk.com
www.emea.lambda.tdk.com/il-en



TDK-Lambda Americas

Tel: +1 800-LAMBDA-4 or 1-800-526-2324
tla.powersolutions@tdk.com
www.us.lambda.tdk.com



TDK Electronics do Brasil Ltda

Tel: +55 11 3289-9599
sales.br@tdk-electronics.tdk.com
www.tdk-electronics.tdk.com/en



TDK-Lambda Corporation

Tel: +81-3-6778-1113
www.jp.lambda.tdk.com



TDK-Lambda (China) Electronics Co. Ltd.

Tel: +86 21 6485-0777
tlc.powersolutions@tdk.com
www.lambda.tdk.com.cn



TDK-Lambda Singapore Pte Ltd.

Tel: +65 6251 7211
tfs.marketing@tdk.com
www.sg.lambda.tdk.com



TDK India Private Limited, Power Supply Division

Tel: +91 80 4039-0660
mathew.philip@tdk.com
www.sg.lambda.tdk.com

