

Mechanical Dimensions: Inches [mm]

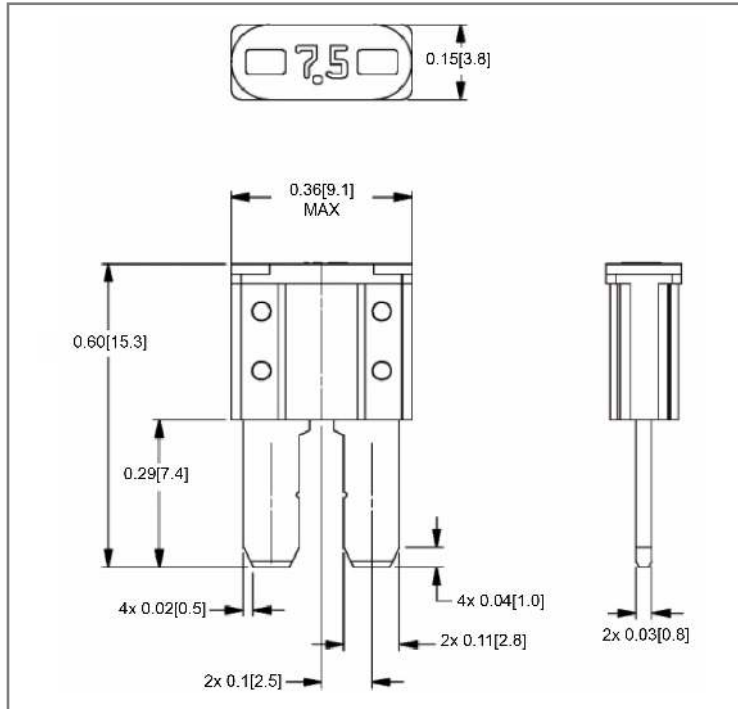

Retail Pack: Inches [mm]

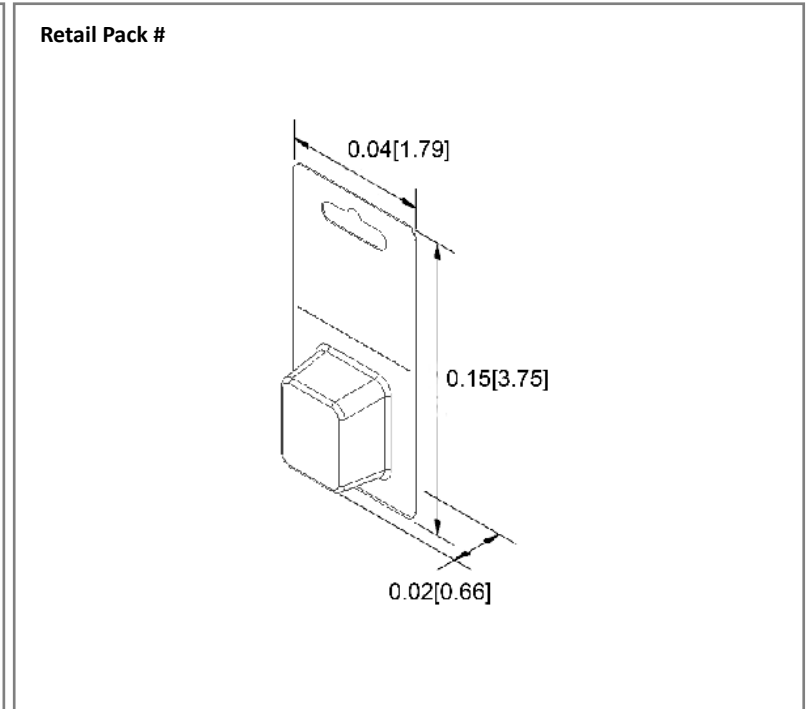

Part Numbers Information

Amperage	Body Color	Bulk Part #	Retail Pack # Blister Card	Pack Size
3A	Violet	ANT-3A	-	-
4A	Pink	ANT-4A	-	-
5A	Tan	ANT-5A	ANT-5A-BP	5
7.5A	Brown	ANT-7.5A	ANT-7.5A-BP	5
10A	Red	ANT-10A	ANT-10A-BP	5
15A	Blue	ANT-15A	ANT-15A-BP	5
20A	Yellow	ANT-20A	ANT-20A-BP	5
25A	Clear	ANT-25A	ANT-25A-BP	5
30A	Green	ANT-30A	ANT-30A-BP	5

Electrical Specifications

Voltage Rating	32V DC
Interrupting Rating	1000A @ 32 VDC
Testing	SAE, ISO 8820

Material Specifications

Body	PA 66
Terminals	Zinc Alloy

Time vs. Percent of Rated Current

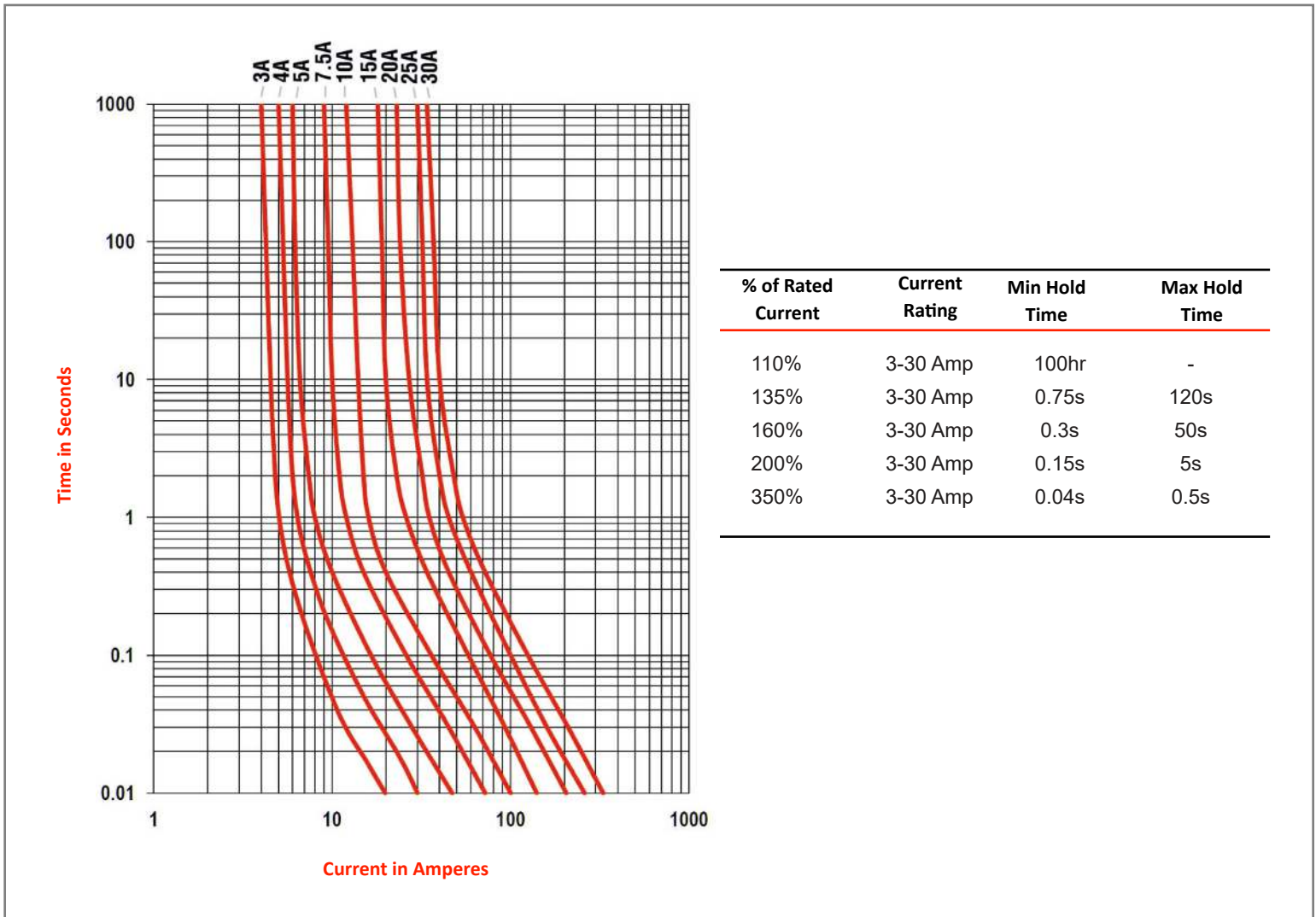

Rev Date of issue Revision Notes

Designed Approved

C	05-22-2023	Initial Drawing	RC	OF
---	------------	-----------------	----	----