

- Including EMI filter to meet EN 55032, class A
- Ultra wide 4:1 input voltage ranges 9–36, 18–75, 43–160 VDC
- EN 50155 approval for railway applications
- Very high efficiency up to 91%
- No minimum load
- Soft start
- Adjustable output voltage +10 / -20%
- Sense line
- Remote On/Off input
- Under voltage lock-out circuit

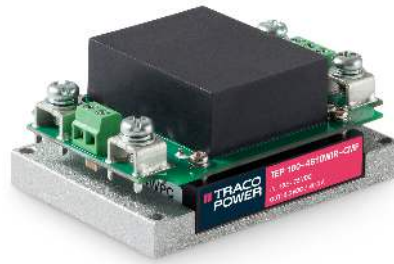

The TEP 160WIRCMF Series is a family of isolated high performance DC/DC converter modules with ultra-wide 4:1 input voltage ranges. They come in chassis mount version with screw terminal block. A very high efficiency allows full power operation without forced air cooling at 25°C. The very wide input voltage range and reverse input voltage protection make these converters interesting solution for battery operated systems. Typical applications are in telecom/datacom, industry control and railway systems for on board power distribution.

Options

TEP-MK1	- Optional DIN-Rail Mounting Kit: www.tracopower.com/products/tep-mk1.pdf
<p>on demand (backorder with MOQ non stocking item)</p>	<ul style="list-style-type: none"> - Optional model with 3.3 VDC / 40'000 mA Output and 9 - 36 VDC Input - Optional model with 5 VDC / 28'000 mA Output and 9 - 36 VDC Input - Optional model with 12 VDC / 12'000 mA Output and 9 - 36 VDC Input - Optional model with 15 VDC / 9'500 mA Output and 9 - 36 VDC Input - Optional model with 24 VDC / 6'000 mA Output and 9 - 36 VDC Input - Optional model with 28 VDC / 5'000 mA Output and 9 - 36 VDC Input - Optional model with 48 VDC / 3'000 mA Output and 9 - 36 VDC Input - Optional model with 3.3 VDC / 40'000 mA Output and 18 - 75 VDC Input - Optional model with 5 VDC / 30'000 mA Output and 18 - 75 VDC Input - Optional model with 12 VDC / 13'000 mA Output and 18 - 75 VDC Input - Optional model with 15 VDC / 10'000 mA Output and 18 - 75 VDC Input - Optional model with 24 VDC / 6'500 mA Output and 18 - 75 VDC Input - Optional model with 28 VDC / 5'500 mA Output and 18 - 75 VDC Input - Optional model with 48 VDC / 3'200 mA Output and 18 - 75 VDC Input - Optional model with 3.3 VDC / 43'000 mA Output and 43 - 160 VDC Input - Optional model with 5 VDC / 32'000 mA Output and 43 - 160 VDC Input - Optional model with 12 VDC / 15'000 mA Output and 43 - 160 VDC Input - Optional model with 15 VDC / 12'000 mA Output and 43 - 160 VDC Input - Optional model with 24 VDC / 7'500 mA Output and 43 - 160 VDC Input - Optional model with 28 VDC / 6'500 mA Output and 43 - 160 VDC Input - Optional model with 48 VDC / 3'800 mA Output and 43 - 160 VDC Input - Optional models with inverse Remote On/Off function (passive = off)

Input Specifications

Input Current	- At no load	110 Vin models: 10 mA typ. 24 Vin models: 20 mA typ. (3.3 Vout model) 25 mA typ. (5 Vout model) 25 mA typ. (12 Vout model) 25 mA typ. (15 Vout model) 25 mA typ. (24 Vout model) 25 mA typ. (28 Vout model) 35 mA typ. (48 Vout model) 48 Vin models: 15 mA typ. (3.3 Vout model) 15 mA typ. (5 Vout model) 20 mA typ. (12 Vout model) 20 mA typ. (15 Vout model) 20 mA typ. (24 Vout model) 20 mA typ. (28 Vout model) 25 mA typ. (48 Vout model)
Surge Voltage		24 Vin models: 50 VDC max. (1 s max.) 48 Vin models: 100 VDC max. (1 s max.) 110 Vin models: 185 VDC max. (1 s max.)
Under Voltage Lockout		24 Vin models: 7.3 VDC min. / 7.7 VDC typ. / 8.1 VDC max. 48 Vin models: 15.5 VDC min. / 16 VDC typ. / 16.3 VDC max. 110 Vin models: 33 VDC min. / 34.5 VDC typ. / 36 VDC max.
Recommended Input Fuse		24 Vin models: 25'000 mA (fast acting) 48 Vin models: 15'000 mA (fast acting) 110 Vin models: 8'000 mA (fast acting) (The need of an external fuse has to be assessed in the final application.)
Input Filter		Internal Pi-Type

Output Specifications

Output Voltage Adjustment		-20% to +10% (By external trim resistor) See application note: www.tracopower.com/overview/tep160wircmf Output power must not exceed rated power!
Voltage Set Accuracy		±1% max.
Regulation	- Input Variation (Vmin - Vmax) - Load Variation (0 - 100%)	0.1% max. 0.1% max.
Ripple and Noise (20 MHz Bandwidth)		3.3 Vout models: 75 mVp-p max. (w/ 1 µF X7R 25 µF poscap) 5 Vout models: 75 mVp-p max. (w/ 1 µF X7R 25 µF poscap) 12 Vout models: 100 mVp-p max. (w/ 1 µF X7R 25 µF poscap) 15 Vout models: 100 mVp-p max. (w/ 1 µF X7R 25 µF poscap) 24 Vout models: 200 mVp-p max. (w/ 4.7 µF X7R) 28 Vout models: 200 mVp-p max. (w/ 4.7 µF X7R) 48 Vout models: 300 mVp-p max. (w/ 2.2 µF X7R)

All specifications valid at nominal voltage, resistive full load and +25°C after warm-up time, unless otherwise stated.

Capacitive Load	- 24 Vin input	3.3 Vout models: 121'000 µF max. 5 Vout models: 56'000 µF max. 12 Vout models: 10'000 µF max. 15 Vout models: 6'300 µF max. 24 Vout models: 2'500 µF max. 28 Vout models: 1'700 µF max. 48 Vout models: 620 µF max.
	- 48 Vin input	3.3 Vout models: 121'000 µF max. 5 Vout models: 60'000 µF max. 12 Vout models: 10'800 µF max. 15 Vout models: 6'600 µF max. 24 Vout models: 2'700 µF max. 28 Vout models: 1'900 µF max. 48 Vout models: 660 µF max.
	- 110 Vin input	3.3 Vout models: 130'000 µF max. 5 Vout models: 64'000 µF max. 12 Vout models: 12'500 µF max. 15 Vout models: 8'000 µF max. 24 Vout models: 3'100 µF max. 28 Vout models: 2'300 µF max. 48 Vout models: 790 µF max.
Minimum Load	Not required	
Temperature Coefficient	±0.02 %/K max.	
Hold-up Time	10 ms min. (acc. to EN 50155 Class S2, see application note for ext. capacitor calculation: www.tracopower.com/info/holdup_en50155.pdf)	
Start-up Time	75 ms typ.	
Short Circuit Protection	Continuous, Automatic recovery	
Output Current Limitation	120 - 150% of Iout max.	
Overvoltage Protection	115 - 130% of Vout nom.	
Transient Response	- Response Time	200 µs typ. / 250 µs max. (25% Load Step)

Safety Specifications

Safety Standards	- IT / Multimedia Equipment	EN 60950-1 EN 62368-1 IEC 60950-1 IEC 62368-1 UL 60950-1 UL 62368-1
	- Railway Applications - Certification Documents	EN 50155 www.tracopower.com/overview/tep160wircmf
Pollution Degree	PD 2	
Over Voltage Category	OVC II	

EMC Specifications

EMI Emissions	- Conducted Emissions	EN 55011 class A (internal filter) EN 55032 class A (internal filter)
	- Radiated Emissions	EN 55011 class A (internal filter) EN 55032 class A (internal filter)

All specifications valid at nominal voltage, resistive full load and +25°C after warm-up time, unless otherwise stated.

EMS Immunity	<ul style="list-style-type: none"> - Electrostatic Discharge - RF Electromagnetic Field - EFT (Burst) / Surge - Conducted RF Disturbances - PF Magnetic Field 	EN 50155 (Railway Applications) EN 50121-3-2 (EMC for Rolling Stock) Air: EN 61000-4-2, ± 8 kV, perf. criteria A Contact: EN 61000-4-2, ± 6 kV, perf. criteria A EN 61000-4-3, 20 V/m, perf. criteria A EN 61000-4-4, ± 2 kV, perf. criteria A EN 61000-4-5, ± 2 kV, perf. criteria A EN 61000-4-6, 10 Vrms, perf. criteria A Continuous: EN 61000-4-8, 100 A/m, perf. criteria A 1 s: EN 61000-4-8, 1000 A/m, perf. criteria A
--------------	--	--

General Specifications

Relative Humidity		95% max. (non condensing)
Temperature Ranges	<ul style="list-style-type: none"> - Operating Temperature - Case Temperature - Storage Temperature 	-40°C to +75°C +115°C max. -40°C to +105°C
Power Derating	<ul style="list-style-type: none"> - High Temperature 	Depending on model See application note: www.tracopower.com/overview/tep160wircmf
Over Temperature Protection Switch Off	<ul style="list-style-type: none"> - Protection Mode - Measurement Point 	120°C typ. (Automatic recovery at 105°C typ.) Base-Plate
Cooling System		Natural convection (20 LFM)
Sense Function		10% max. of Vout nom. (Sense line to be connected to the output either at the module or at the load under regard of polarity)
Remote Control	<ul style="list-style-type: none"> - Voltage Controlled Remote - Off Idle Input Current - Remote Pin Input Current 	On: 3.0 to 12 VDC or open circuit Off: 0 to 1.2 VDC or short circuit Refers to 'Remote' and '-Vin' Pin 3 mA typ. -0.5 to 1.0 mA (Optional models with inverse Remote On/Off function (passive = off))
Altitude During Operation		2'000 m max. (for reinforced insulation) 5'000 m max. (for functional insulation)
Switching Frequency		225 - 275 kHz (PWM) 250 kHz typ. (PWM)
Insulation System		Reinforced Insulation
Working Voltage (rated)		145 VAC (3.3 and 5 Vout models) 185 VAC (48 Vout models) 172 VAC (other output models)
Isolation Test Voltage	<ul style="list-style-type: none"> - Input to Output, 60 s - Input to Case, 60 s - Output to Case, 60 s 	3'000 VAC 1'500 VAC 1'500 VAC
Isolation Resistance	- Input to Output, 500 VDC	1'000 M Ω min.
Isolation Capacitance	- Input to Output, 100 kHz, 1 V	2'500 pF max.
Reliability	- Calculated MTBF	350'000 h (MIL-HDBK-217F, ground benign)
Environment	<ul style="list-style-type: none"> - Vibration - Mechanical Shock - Thermal Shock 	MIL-STD-810F EN 61373 MIL-STD-810F EN 61373 MIL-STD-810F EN 50155
Housing Material		Alu base-plate w. metal case (24 and 48 Vin models) Alu base-plate w. plastic case (110 Vin models)
Base Material		Non-conductive FR4 (UL 94 V-0 rated) (24 and 48 Vin models only)

All specifications valid at nominal voltage, resistive full load and +25°C after warm-up time, unless otherwise stated.

Potting Material	Silicone (UL 94 V-0 rated)
Housing Type	Metal Case (24 and 48 Vin models) Plastic Case (110 Vin models)
Mounting Type	Chassis Mount
Connection Type	Screw Terminal
Weight	287 g
Thermal Impedance	- Case to Ambient 6.1 K/W typ.
Environmental Compliance	- REACH Declaration www.tracopower.com/info/reach-declaration.pdf REACH SVHC list compliant REACH Annex XVII compliant - RoHS Declaration www.tracopower.com/info/rohs-declaration.pdf Exemptions: 7a, 7c-I (RoHS exemptions refer to the component concentration only, not to the overall concentration in the product (O5A rule)) - SCIP Reference Number 50acc1a9-e38b-4509-8921-bfa0568ea954 - Flammability (EN 45545-2) www.tracopower.com/info/en45545-declaration.pdf

Supporting Documents

Overview Link (for additional Documents)

www.tracopower.com/overview/tep160wircmf

Outline Dimensions

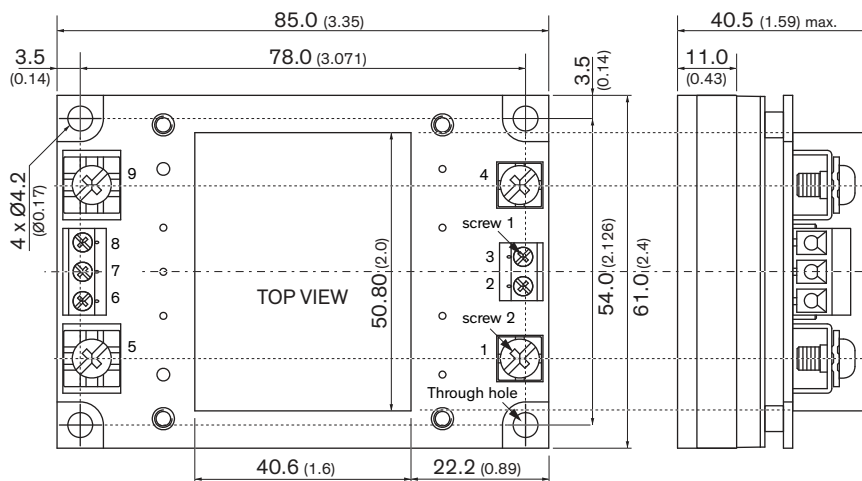

Pinout	
Pin	Single
1	-Vin (GND)
2	Case
3	Remote On/Off
4	+Vin (Vcc)
5	-Vout
6	-Sense
7	Trim
8	+Sense
9	+Vout

Dimensions in mm (inch)

Tolerances $x.x \pm 0.5$ ($x.xx \pm 0.02$)

$x.xx \pm 0.25$ ($x.xxx \pm 0.01$)

Mounting hole pitch tolerances ± 0.25 (± 0.01)

Screw 2:

Type M5

Head diameter 8.9 (0.350)

Rated current: 65 A

The screw 1 locked torque: max. 5.2 kgfcm / 0.51 Nm

The screw 2 locked torque: max. 16.5 kgfcm / 1.65 Nm