

REV.	DATE	ECR NO.	DESCRIPTION
NC	03/22/10	-	INITIAL RELEASE

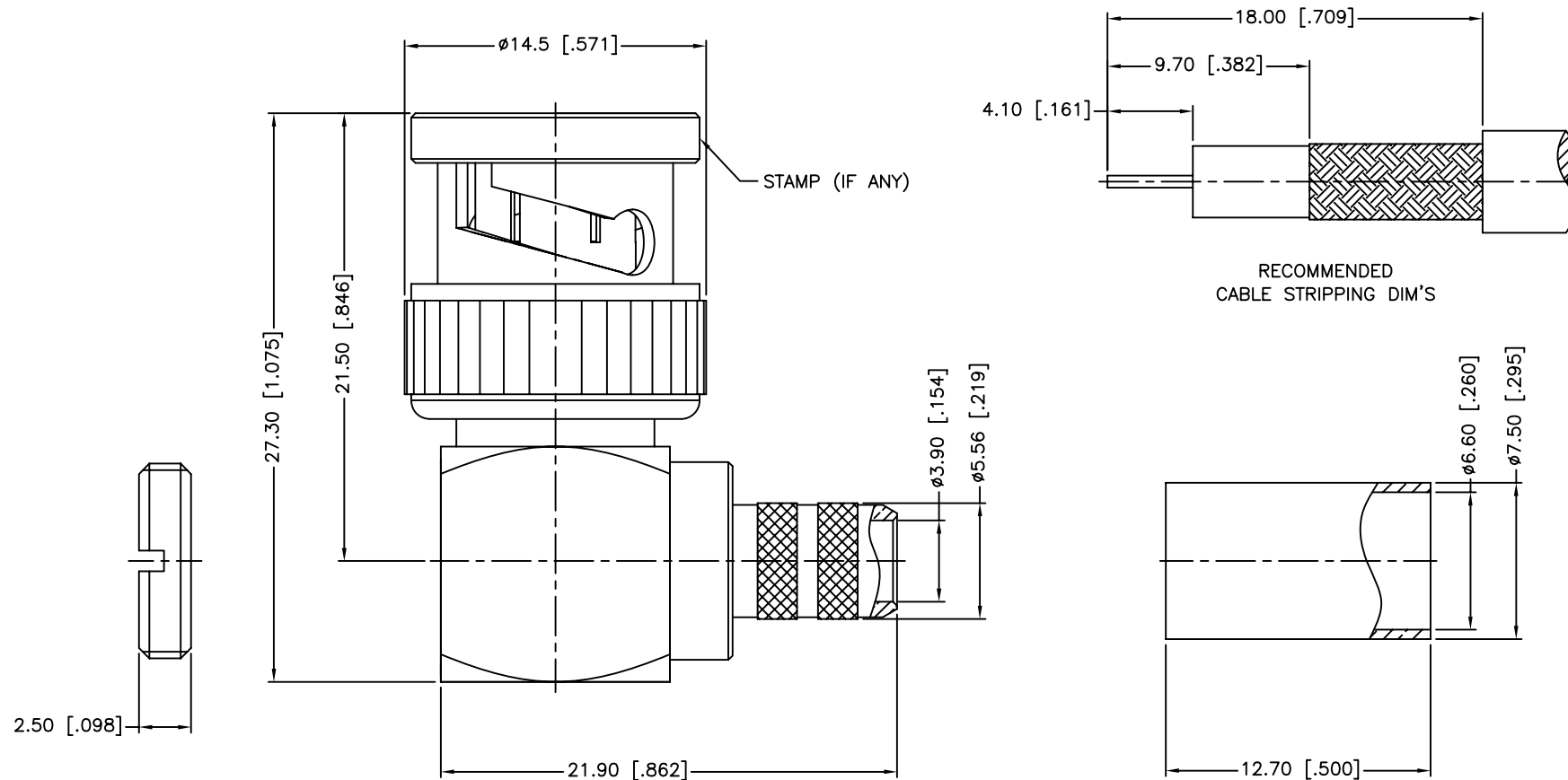

NOTE:
1. CRIMPED FERRULE
HEX CRIMP SIZE .255"

11	NUT	BRASS	NICKEL	1
10	FERRULE	BRASS	NICKEL	1
9	WASHER	BRASS	NICKEL	1
8	SPRING	SK5	NICKEL	1
7	RETAINER RING	BRASS	NICKEL	1
6	GASKET	RUBBER	RED	1
5	CONTACT PIN	BRASS	GOLD	1
4	INSULATOR	DELTRIN	NATURAL	1
3	BARREL	BRASS	NICKEL	1
2	HOUSING	BRASS	NICKEL	1
1	SHELL	BRASS	NICKEL	1
	DESCRIPTION	MATERIAL	FINISH	QTY

UNLESS OTHERWISE SPECIFIED DIMENSIONS ARE IN MILLIMETERS. DIMENSIONS IN [] ARE IN INCHES AND FOR CUSTOMER REFERENCE ONLY.

UNLESS OTHERWISE SPECIFIED TOLERANCES FOR MILLIMETERS ARE:
0.5 - 8mm ± 0.20mm
8 - 30mm ± 0.40mm
30 - 120mm ± 0.50mm

UNLESS OTHERWISE SPECIFIED TOLERANCES FOR INCHES ARE:
.020 - .315 ± 0.007"
.315 - 1.180 ± 0.015"
1.180 - 4.724 ± 0.020"

DO NOT SCALE DRAWING

APPROVALS	DATE
DRAWN M.ZHANG	03/22/10
CHECKED	
ISSUED	
SHEET 1 OF 1	
CAD FILE	C:/CONNEX/112165.DWG

Amphenol Connex			
PART DESCRIPTION BNC R/A CRIMP PLUG (FOR RG-59/U CABLE 75 ohms)			
PART NO.		112165	
DWG. NO.	112165.DWG	REV. NC	SIZE A
		SCALE	NA