

RF CHARACTERISTICS

Number of ways : 12
 Frequency range : 0 - 18 GHz
 Impedance : 50 Ohms

Frequency (GHz)	DC - 3	3 - 8	8 - 12.4	12.4 - 15	15 - 18
VSWR max	1,20	1,40	1,60	1,70	1,80
Insertion loss max	0.20 dB	0.40 dB	0.60 dB	0.70 dB	0.80 dB
Isolation min	80 dB	70 dB	60 dB	60 dB	50 dB
Average power (*)	240 W	150 W	120 W	110 W	100 W

TERMINATION IMPEDANCE : 50 Ohms
 TERM. AVG. POWER AT 25° C : 1 W per termination / 3 W total power

ELECTRICAL CHARACTERISTICS

Actuator : LATCHING
 Nominal current ** : 1280 mA
 Actuator voltage (Vcc) : 12V (10.2 to 13V)
 Terminals : 44 pins D-SUB male connector
 Indicator rating : 1 W / 30 V / 100 mA
 Self cut-off time : 40 ms < CT < 120 ms
 TTL inputs (E) - High level : 2.2 to 5.5 V / 800µA at 5.5 V
 - Low level : 0 to 0.8 V / 20µA at 0.8 V

MECHANICAL CHARACTERISTICS

Connectors : SMA female per MIL-C 39012
 Life : 2 million cycles per position
 Switching Time*** : < 50 ms
 Construction : Splashproof
 Weight : < 400 g

ENVIRONMENTAL CHARACTERISTICS

Operating temperature range : -40°C to +85°C
 Storage temperature range : -55°C to +85°C

(* Average power at 25°C per RF Path)
 (** At 25° C ±10%)
 (***) Nominal voltage ; 25° C)



PAGE 2/2

ISSUE 25-11-22

SERIE : SPnT

PART NUMBER : R574F92225

DRAWING

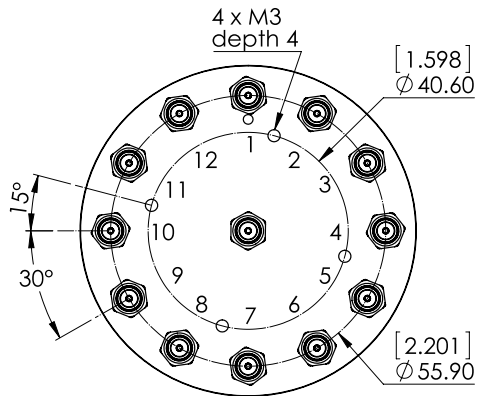

TTL input	RF Continuity	Ind.
E1 = 1	IN ↔ 1	D.E
E2 = 1	IN ↔ 2	D.F
E3 = 1	IN ↔ 3	D.G
E4 = 1	IN ↔ 4	D.H
E5 = 1	IN ↔ 5	D.I
E6 = 1	IN ↔ 6	D.J
E7 = 1	IN ↔ 7	D.K
E8 = 1	IN ↔ 8	D.L
E9 = 1	IN ↔ 9	D.M
E10 = 1	IN ↔ 10	D.N
E11 = 1	IN ↔ 11	D.O
E12 = 1	IN ↔ 12	D.P

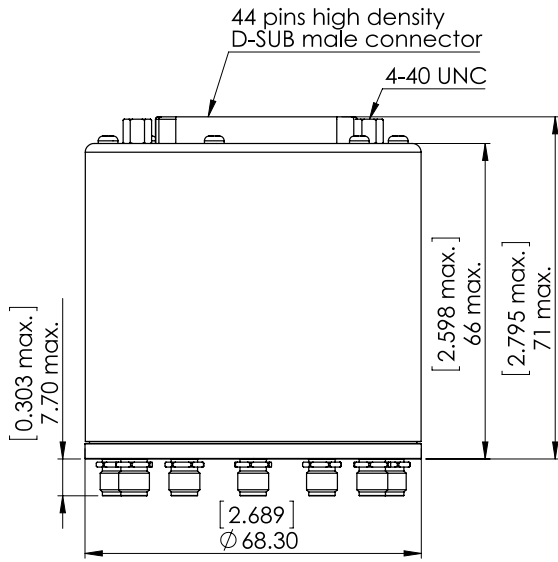

General tolerances : ±0,5 mm [0,02 in]

LABEL

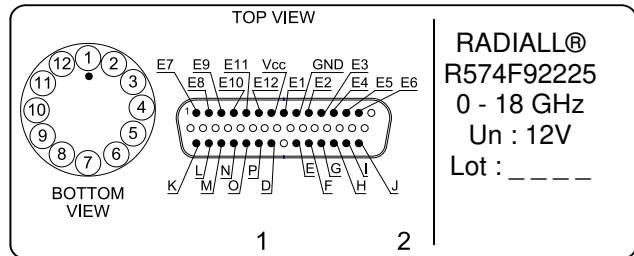

SCHEMATIC DIAGRAM

