

OPTION G

- NOTES:
 1. MATERIAL:
 HOUSING: POLYESTER(PBT), GLASS FILLED, UL94 V-0,
 COLOR: BLACK
 TERMINAL: PHOSPHOR BRONZE
2. FINISH:
 15 GOLD: 0.38 MICROMETERS/15 MICROINCHES MINIMUM GOLD IN
 1.91 MICROMETERS/75 MICROINCHES MINIMUM TIN
 OVER NICKEL UNDERPLATE OVERALL
3. TO BE USED WITH 24 AWG STRANDED WIRE WITH (1.35)/.053
 DIAMETER MAXIMUM INSULATION
4. SEE TABLE FOR AVAILABLE CIRCUIT SIZES
5. STANDARD PACKAGING PER PK-70873-0001. OPTIONAL PACKAGING
 MAY BE AVAILABLE, REQUEST DRAWING PK-70400
6. PARTS STACKABLE END TO END ON (2.54)/.100 CENTERS
7. PRODUCT SPECIFICATION: PS-70400
8. SEE DRAWING SDA-70400-**** (SHEET 3) FOR OPTIONAL
 HOUSING DETAILS
9. 4 CIRCUIT SHOWN. 3-25 CIRCUITS HAVE 2 RIBS
 10. TO MATE WITH MOLEX PART NUMBERS: A-70373-****,
 A-70375-****, A-70389-****, A-70391-****,
 A-70107-****, A-70018-****, A-70543-****,
 A-70553-****, A-70541-****, A-70551-****,
 A-70545-****, A-70555-****
11. 2 CIRCUIT ASSEMBLIES SUPPLIED AS GROUPED PAIRS

CKT. SIZE	A	B	EDP. NO.
2	(2.54) .100	(5.05) .199	14-56-2022
3	(5.08) .200	(7.59) .299	14-56-2032
4	(7.62) .300	(10.13) .399	14-56-2042
5	(10.16) .400	(12.67) .499	14-56-2052
6	(12.70) .500	(15.21) .599	14-56-2062
7	(15.24) .600	(17.75) .699	14-56-2072
8	(17.78) .700	(20.29) .799	14-56-2082
9	(20.32) .800	(22.83) .899	14-56-2092
10	(22.86) .900	(25.37) .999	14-56-2102
11	(25.54) 1.000	(27.91) 1.099	14-56-2112
12	(27.94) 1.100	(30.45) 1.199	14-56-2122
13	(30.48) 1.200	(32.99) 1.299	14-56-2132
14	(33.02) 1.300	(35.53) 1.399	14-56-2142
15	(35.56) 1.400	(38.07) 1.499	14-56-2152
16	(38.01) 1.500	(40.61) 1.599	14-56-2162
17	(40.64) 1.600	(43.15) 1.699	14-56-2172
18	(43.18) 1.700	(45.69) 1.799	14-56-2182
19	(45.72) 1.800	(48.23) 1.899	14-56-2192
20	(48.26) 1.900	(50.77) 1.999	14-56-2202
21	(50.80) 2.000	(53.31) 2.099	14-56-2212
22	(53.34) 2.100	(55.85) 2.199	14-56-2222
23	(55.88) 2.200	(58.39) 2.299	14-56-2232
24	(58.42) 2.300	(60.93) 2.399	14-56-2242
25	(60.96) 2.400	(63.47) 2.499	14-56-2252

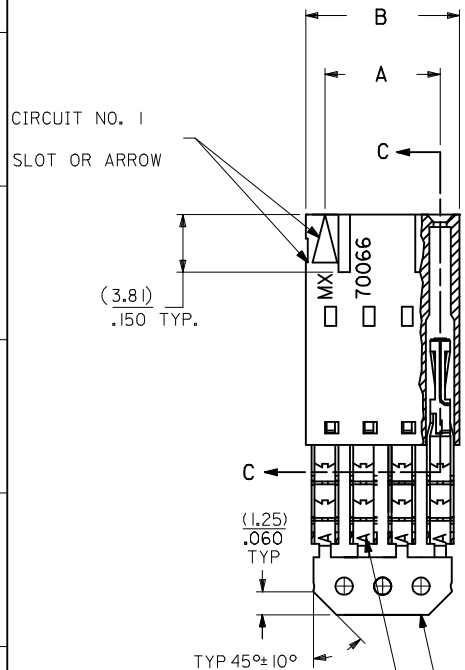
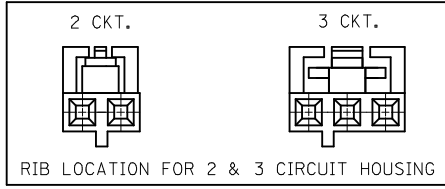
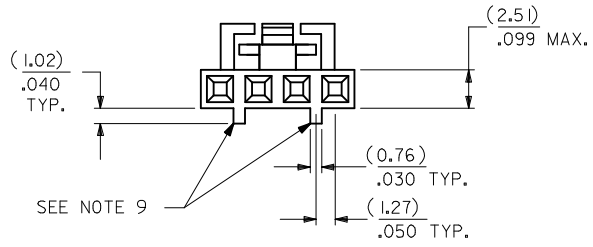

SECTION C-C

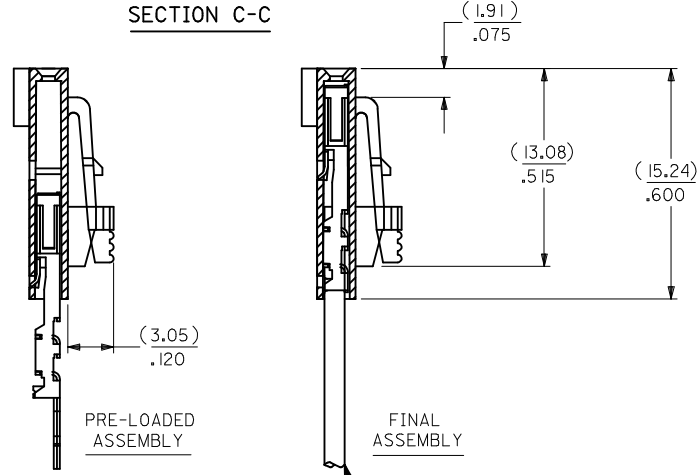

I.D. SLOT CODE TO WIRE GAUGE CHART	
I.D. SLOT CODE	WIRE GAUGE
A	24 AWG.

PLATING CODE (STRIPE ON CARRIER STRIP)	
PLATING	COLOR
15 GOLD	YELLOW

REMOVE ENG NO. 2010/10/19
 EC NO: UCP2011-110
 DRW:MSI BARRA 2010/10/19
 CHK:DJMORGAN 2010/10/19
 APPR:SMILLER 2010/11/24

QUALITY SYMBOLS
 ∇=0
 ∇=0
 ∇=0

GENERAL TOLERANCES (UNLESS SPECIFIED)

	mm	INCH
4 PLACES	± .15	± .005
3 PLACES	± .10	± .004
2 PLACES	± .075	± .003
1 PLACE	± .05	± .002

 ANGULAR ±1/2°

DRAFT WHERE APPLICABLE MUST REMAIN WITHIN DIMENSIONS

WIRE (SEE NOTE 3)

DIMENSION STYLE		SCALE	DESIGN UNITS	THIRD ANGLE PROJECTION
MM/IN			INCH	
DRAWN BY	DATE	TITLE		
MSI BARRA	2010/10/19	ASSEMBLY, SL CONNECTOR SINGLE ROW 2.54/.100 GRID		
CHECKED BY	DATE			
WAZ	1984/10/09			
APPROVED BY	DATE			
SMILLER	2010/11/24			
MATERIAL NO.	DOCUMENT NO.			
SEE TABLE	SDA-70400-0666-0689			
SIZE	THIS DRAWING CONTAINS INFORMATION THAT IS PROPRIETARY TO MOLEX INCORPORATED AND SHOULD NOT BE USED WITHOUT WRITTEN PERMISSION		SHEET NO. 1 OF 1	

OPTION G

- NOTES:
 1. MATERIAL:
 HOUSING: POLYESTER(PBT), GLASS FILLED, UL94 V-0,
 COLOR: BLACK
 TERMINAL: PHOSPHOR BRONZE
2. FINISH:
 15 GOLD: 0.38 MICROMETERS/15 MICROINCHES MINIMUM GOLD IN
 1.91 MICROMETERS/75 MICROINCHES MINIMUM TIN
 OVER NICKEL UNDERPLATE OVERALL
3. TO BE USED WITH 24 AWG STRANDED WIRE WITH (1.35)/.053
 DIAMETER MAXIMUM INSULATION
4. SEE TABLE FOR AVAILABLE CIRCUIT SIZES
5. STANDARD PACKAGING PER PK-70873-0001. OPTIONAL PACKAGING
 MAY BE AVAILABLE, REQUEST DRAWING PK-70400
6. PARTS STACKABLE END TO END ON (2.54)/.100 CENTERS
7. PRODUCT SPECIFICATION: PS-70400
8. SEE DRAWING SDA-70400-**** (SHEET 3) FOR OPTIONAL
 HOUSING DETAILS
9. 4 CIRCUIT SHOWN. 3-25 CIRCUITS HAVE 2 RIBS
10. TO MATE WITH MOLEX PART NUMBERS: A-70373-****,
 A-70375-****, A-70389-****, A-70391-****,
 A-70107-****, A-70018-****, A-70543-****,
 A-70553-****, A-70541-****, A-70551-****,
 A-70545-****, A-70555-****
11. 2 CIRCUIT ASSEMBLIES SUPPLIED AS GROUPED PAIRS

CKT. SIZE	A	B	EDP. NO.
2	(2.54) .100	(5.05) .199	14-56-2022
3	(5.08) .200	(7.59) .299	14-56-2032
4	(7.62) .300	(10.13) .399	14-56-2042
5	(10.16) .400	(12.67) .499	14-56-2052
6	(12.70) .500	(15.21) .599	14-56-2062
7	(15.24) .600	(17.75) .699	14-56-2072
8	(17.78) .700	(20.29) .799	14-56-2082
9	(20.32) .800	(22.83) .899	14-56-2092
10	(22.86) .900	(25.37) .999	14-56-2102
11	(25.54) 1.000	(27.91) 1.099	14-56-2112
12	(27.94) 1.100	(30.45) 1.199	14-56-2122
13	(30.48) 1.200	(32.99) 1.299	14-56-2132
14	(33.02) 1.300	(35.53) 1.399	14-56-2142
15	(35.56) 1.400	(38.07) 1.499	14-56-2152
16	(38.01) 1.500	(40.61) 1.599	14-56-2162
17	(40.64) 1.600	(43.15) 1.699	14-56-2172
18	(43.18) 1.700	(45.69) 1.799	14-56-2182
19	(45.72) 1.800	(48.23) 1.899	14-56-2192
20	(48.26) 1.900	(50.77) 1.999	14-56-2202
21	(50.80) 2.000	(53.31) 2.099	14-56-2212
22	(53.34) 2.100	(55.85) 2.199	14-56-2222
23	(55.88) 2.200	(58.39) 2.299	14-56-2232
24	(58.42) 2.300	(60.93) 2.399	14-56-2242
25	(60.96) 2.400	(63.47) 2.499	14-56-2252

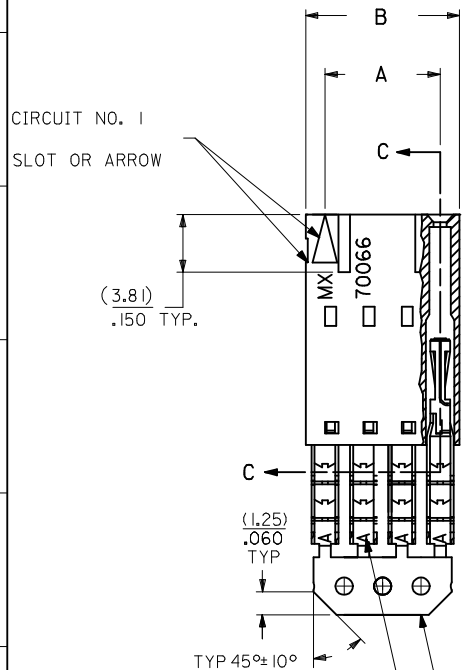
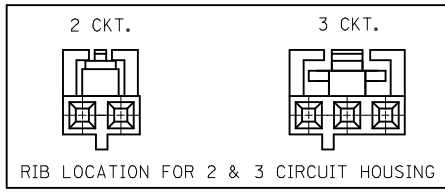
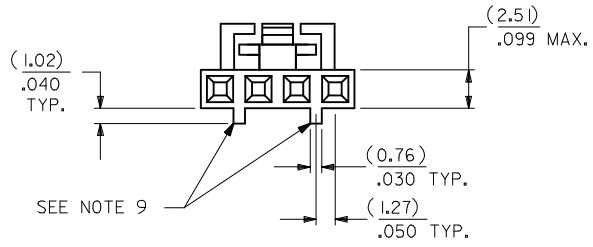

SECTION C-C

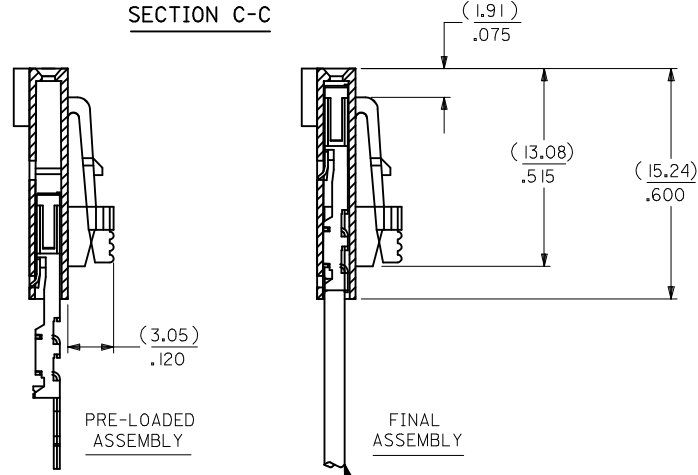

I.D. SLOT CODE TO WIRE GAUGE CHART	
I.D. SLOT CODE	WIRE GAUGE
A	24 AWG.

PLATING CODE (STRIPE ON CARRIER STRIP)	
PLATING	COLOR
15 GOLD	YELLOW

REMOVE ENG. NO. EC NO: UCP2011-110 DRW:MSI BARRA 2010/10/19 CHK:DJMORGAN 2010/10/19 APPR:SMILLER 2010/11/24	QUALITY SYMBOLS ∇=0 ∇=0 ∇=0	GENERAL TOLERANCES (UNLESS SPECIFIED) mm INCH 4 PLACES ± --- ± --- 3 PLACES ± --- ± .010 2 PLACES ± 0.25 ± .014 1 PLACE ± 0.35 ± --- ANGULAR ±1/2°	DIMENSION STYLE MM/IN DRAWN BY DATE MSIBARRA 2010/10/19 CHECKED BY DATE WAZ 1984/10/09 APPROVED BY DATE SMILLER 2010/11/24	SCALE INCH DESIGN UNITS INCH THIRD ANGLE PROJECTION	TITLE ASSEMBLY, SL CONNECTOR SINGLE ROW 2.54/.100 GRID
		DRAFT WHERE APPLICABLE MUST REMAIN WITHIN DIMENSIONS	MATERIAL NO. SEE TABLE	DOCUMENT NO. SDA-70400-0666-0689	SHEET NO. 1 OF 1
		THIS DRAWING CONTAINS INFORMATION THAT IS PROPRIETARY TO MOLEX INCORPORATED AND SHOULD NOT BE USED WITHOUT WRITTEN PERMISSION			
		MOLEX INCORPORATED			