

PRODUCT NUMBER  
91269-XXXXLF

PLATING

- RoHS COMPATIBLE, SEE NOTE 6
- PACKAGING TYPE, NOTE 3
- TOTAL NB OF POSITIONS, 3 TO 17

- 0 = 0.20µm GOLD/GXT ON CONTACT AREA  
2.0µm MIN MATTE TIN ON TAILS
- 1 = 0.76µm GOLD/GXT ON CONTACT AREA  
2.0µm MIN MATTE TIN ON TAILS
- 3 = 0.38µm GOLD/GXT ON CONTACT AREA  
2.0µm MIN MATTE TIN ON TAILS  
UNDERPLATING 1.27µm Ni MIN
- T = FULL MATTE TIN 2µm-5µm  
1.27µm Ni MIN UNDERPLATING

NOTES:

- 1 - HOUSING MAT'L : HIGH TEMPERATURE THERMOPLASTIC. UL94V-0 COLOR: CREAM
- 2 - PIN MATERIAL : COPPER ALLOY
- 3 - PACKAGING  
= POLYBAGS  
TR = TAPE & REEL AS AVAILABLE.
- 4 - 7N MIN RETENTION IN EITHER DIRECTION
- 5 - TO DETERMINE DIMENSIONS :  
N = NUMBER OF POSITIONS  
EXAMPLE : 8 POS N x 2.0= 16.0mm
- 6 - RoHS COMPATIBLE PRODUCT SPECIFICATIONS
  - a - MANUFACTURING PROCESS COMPATIBILITY  
- THE HOUSING WILL WITHSTAND EXPOSURE TO 260°C ±5°C SOLDER BATH TEMPERATURE FOR 5 SECONDS IN A WAVE SOLDER APPLICATION WITH A 1.6mm MIN THICK CIRCUIT BOARD.
  - b - LABELLING:  
- MEETS PACKAGING SPECS AS PER GS-14-920
  - c - THIS PRODUCT MEETS EUROPEAN DIRECTIVES AND OTHER COUNTRY REGULATIONS AS DISCRIBED IN GS-47-0004
- 7 - HOLE DIMENSION TO BE  $\phi 1.6 \pm 0.03$  FOR INTERFERENCE FIT APPLICATIONS, SEE SHEET 2. HOLE DIMENSIONS TO BE  $\phi 1.95 \pm 0.05$  FOR LOCATION APPLICATION WITH AUTOMATIC PICK AND PLACE MACHINES.
- 8 - ODD NBR OF POS : 7.00mm  
EVEN NBR OF POS : 5.00mm

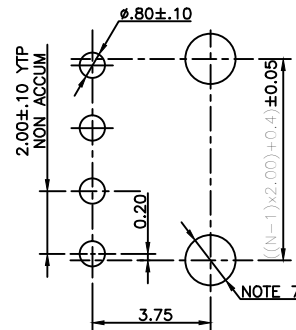

RECOMMENDED HOLE PATTERN  
SEE NOTE 7

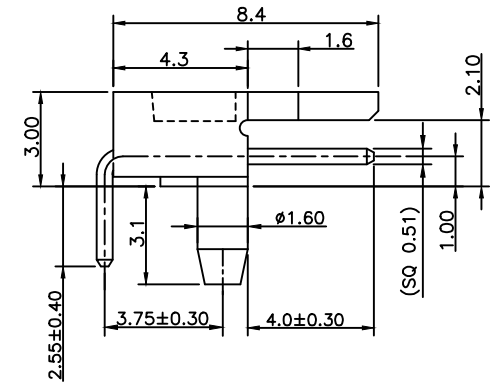
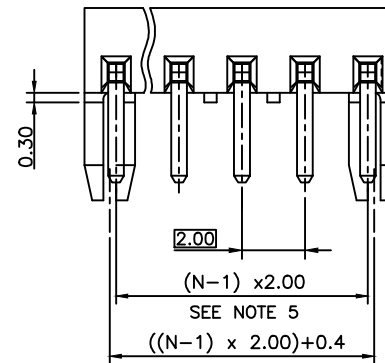
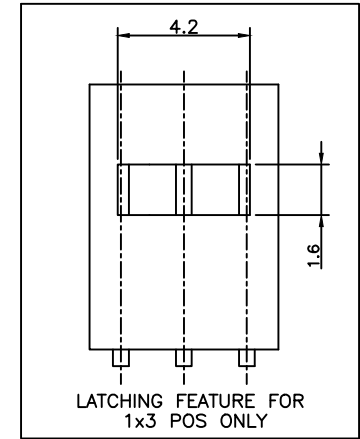
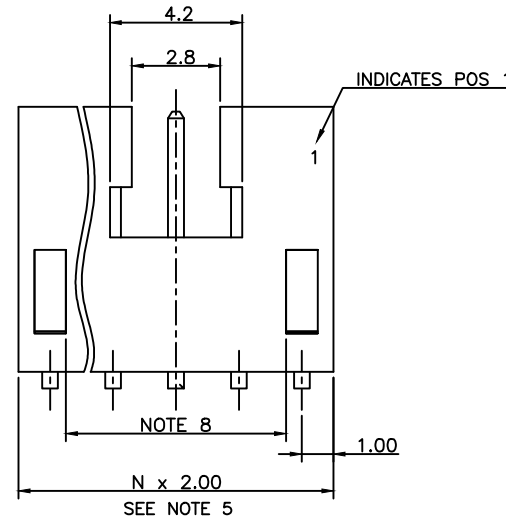

mat'l. code		surface		tolerance		projection		product family	
SEE TABLE		ISO 1302 ✓		ISO 406 ISO 101		mm		MINITEK	
ltr	ecn no	dr	date	tolerances unless otherwise specified		mm		title	
L	B-16822	JCO	14.01.23	angles	.X ±0.3	mm		MINITEK, TMT, SR	
M	B-19186	LMU	14.10.24	linear	.XX ±0.13	mm		RA, POL & LATCHING	
N	B-19986	JCO	15.01.13	±2'	.XXX ±0.05	scale 5:1		dwg no	
P	B-19995	JCO	15.01.15	dr	J. FABRE 13.01.07	FCI		sheet 1 of 2 size	
R	F-23053	AMA	16.01.15	engr	J. FABRE 13.01.07	FCI		91269 A3	
				chr	P.NIZZI 13.01.07	FCI		type	
K	B-16048	JCO	13.10.14	appd	JM.C 13.01.07	FCI		CUSTOMER Drawing	
sheet	revision	R	A						
index	sheet	1	2						

# RECOMMENDATION TO PLACE THE CONNECTOR ONTO THE PCB

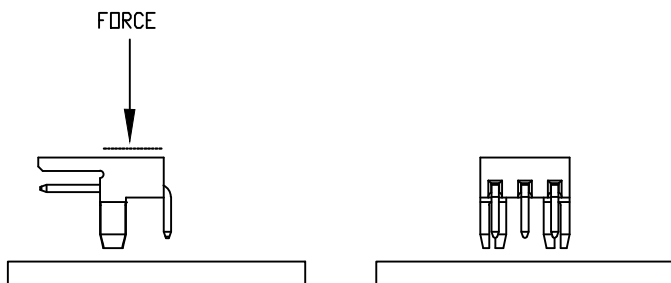
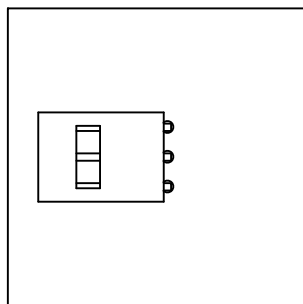

NO FORCE TO BE APPLIED ON THIS AREA, RISK TO BREAK THE WALL

PLACE THE CONNECTOR ON TO THE PCB BY HAND OR WITH A TOOL BY PUSHING ON THIS AREA

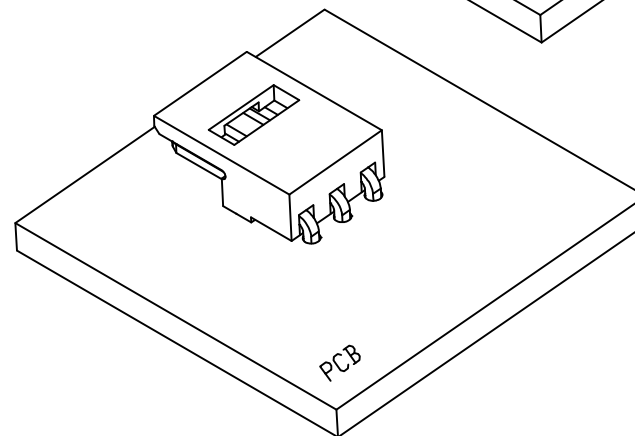
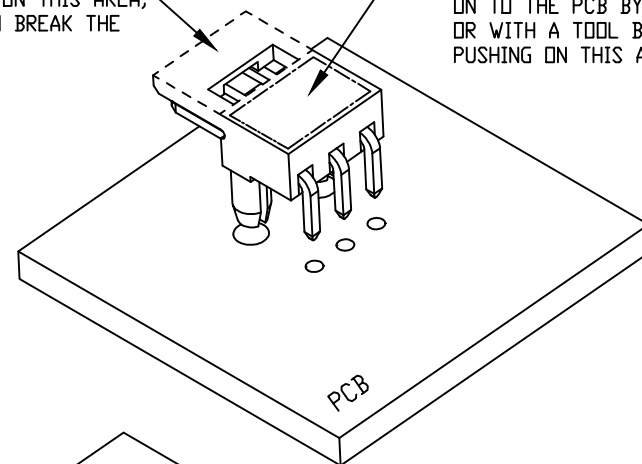

Copyright FCJ

mat'l. code		N/A		surface		ISO 1302 ✓		tolerance		ISO 406 ISO 1101		projection		product family	
ltr		ecn no		dr		date		tolerances unless otherwise specified		mm		title		MINITEK	
A		B-19986		JCO		15.01.13		angles		.0±.x		MINITEK TMT HDR SR		POLARIZATION & LATCHING	
								Linear		.00±.0x		scale 1:1		dwg no	
								0°±x'		.000±.00x		FCJ		sheet 2 of 2	
						dr		J.FABRE		15.01.07				size	
						enr		L.MULIN		15.01.07				A3	
						chr		J.COMPAGNON		15.01.12				91269	
						appd		JCO		15.01.13				type	
sheet index		revision sheet													